

SSC Series

Subcooled Condensers

Patent Pending

CRN13987.5

The SSC, Sanitary Subcooled Condenser is a patent pending sanitary condensate chamber and steam trap assembly that was designed to replace the 12-18" downcomer (drip leg) traditionally installed between SIP temperature sensors and sanitary steam traps. It is ASME BPE 2007 compliant, being constructed of ASTM A479 316L barstock, fully drainable, and polished to SF1, 20 Ra μin (0,5 Ra μm), or optionally to SF5, 20 Ra μin electropolished.

OPERATION

As spent condensate and wet steam exit sterilized process tubing or equipment, the SSC rapidly removes enthalpy, subcooling the condensate below its saturation temperature. As the cooler condensate enters the sanitary steam trap, it causes the trap bellows to contract. The contracted bellows opens the trap orifice further allowing greater amounts of condensate to exit the system.

The finned-chamber geometry of the SSC offers the best available technology for insuring rapid SIP heat-up and uninterrupted hold cycles, while offering a more economical alternative (re: space utilization and capital costs) to conventional downcomer designs.

SPECIFICATIONS

- ASME BPE 2007 Compliant
- ASTM A479 316L barstock construction
- Teflon/stainless and Silverback™ gaskets certified to FDA 21 CFR 177, and USP <88> Class VI
- SF1, 20 Ra μin (0,5 Ra μm) internal surface finish standard; SF5, 20 Ra μin (0,5 Ra μm) electropolish optional
- 3/4" Tri-Clamp® end connections standard
- Fully drainable in full size or compact configuration
- Max water flow capacity: 24,773#/hr @ 15 psi-d (11,236 kg/hr @ 1.03 bar-d)
- Max pressure rating: 145 psig
- Minimum port diameter: 0.62" (15,75 mm)

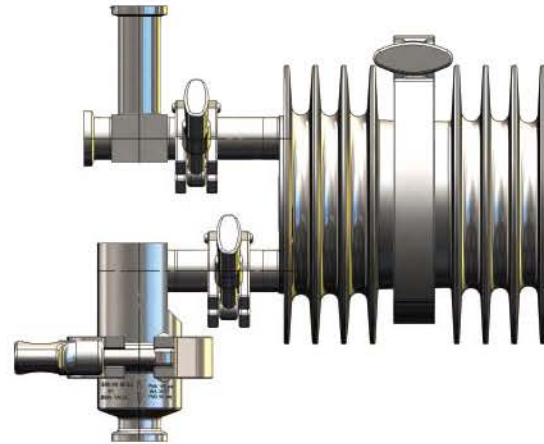

FEATURES

Project CAPEX savings on new, or retrofit installations

- The SSC can significantly reduce Project CAPEX by reducing SIP temperature sensor/trap assembly TIC (total installed cost), by reducing the cost for OEM process skids, or for retrofit and new site built installations. The savings accrue from the SSC's smaller installed space envelope relative to traditional site built SIP downcomer assemblies, and from the installation labor, materials handling and purchasing expense reduction associated with the purchase of a prefabricated SSC SIP Assembly.
 - TIC (Total Installed Cost) reductions
 - Significant reductions in Installation Labor and Material Handling costs: Everything comes preassembled sealed in tagged plastic bags: no on site material consolidation, staging, tube bending, assembly, welding, polishing, or work inspection labor costs
 - One purchase order for Tubing, Fittings, Valves, Temperature Sensor, and Steam Trap
 - Process skid capital cost reduction:
 - Use of the SSC will result in up to 15" skid height reduction – lower overall process skid material and labor costs
 - Process retrofit capital cost reduction:
 - SSC allows use of SIP steam trap/sensor in vertically constrained spaces (under vessels) without altering vessel height or requiring thru-the-floor downcomers

How does the SSC reduce the installed space envelope required for SIP downcomer assemblies?

- The SSC reduces the lineal and vertical distance needed between the SIP temp sensor and the steam trap by a minimum of 80%.
 - With the SSC, vertical head space is reduced by 15.6" if enduser practice calls for the industry preferred 18" lineal - vertical downcomer. For 18" - 12" vertical, bent tube installations, the savings are 9.6".
 - With the SSC, vertical head space reductions on 12" vertical tube downcomer (industry minimum lineal distance) assemblies is also 9.6". See installations.

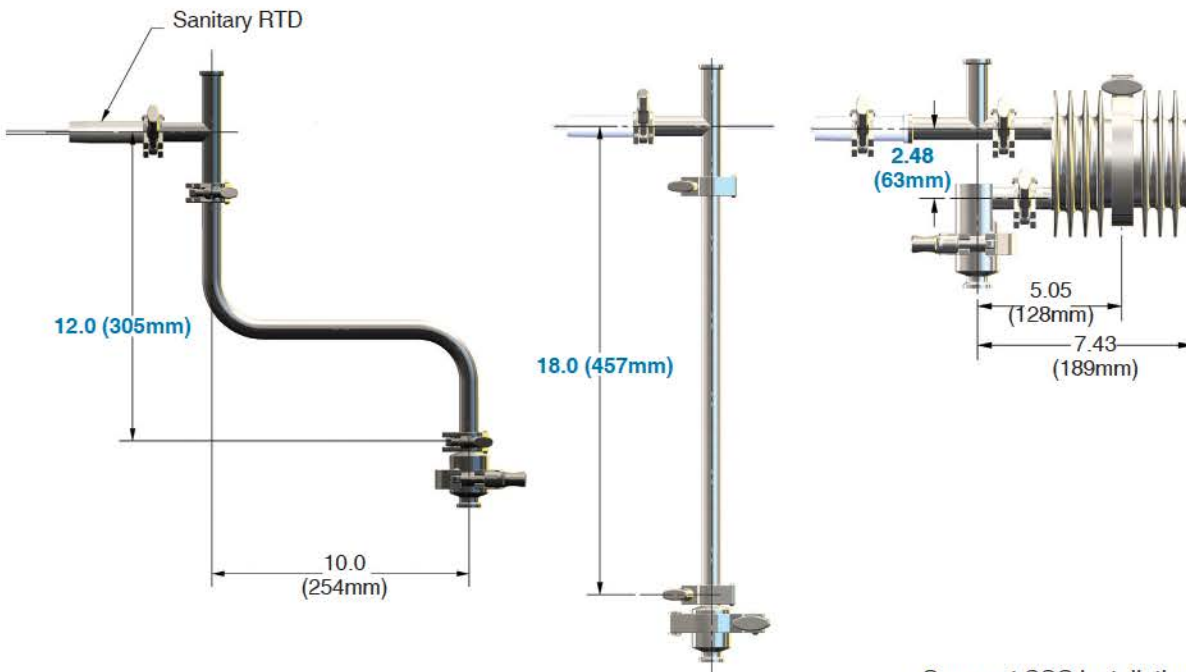

Typical 18" lineal, 12" vertical (bent tube) downcomer assembly

Compact SSC installation requires only 2.37" between sensor tee and trap inlet

FEATURES

Increased Process Availability

- The SSC increases process equipment availability by reducing average annual SIP time. The device dramatically reduces the probability of SIP wetted temperature sensor faults, and total heat-up time. The SSC design makes it impossible for spent condensate to touch (cool) the SIP temperature sensor upstream of the trap under expected load conditions. And, it ensures that condensate cannot cool (and insulate) critical process areas that are being sterilized during heat-up or temperature hold periods.

The SSC increases the volumetric condensate holding capacity immediately upstream of the trap

- by 4 times that of the industry's typical 3/4", 18" lineal sanitary tubing downcomer, and 6 times the industry's minimum recommended 12" downcomer. This compact, extra capacity ensures that spent condensate is completely removed from the temperature sensor area, and from the tubing, vessel, or process equipment being sterilized.

The SSC provides more than 5 times the effective cooling capacity than the typical 3/4", 18"

- lineal sanitary downcomer. Condensate entering the trap is thoroughly subcooled regardless of the steam traps subcooling performance. This ensures that the steam trap is fully open during the high condensate load SIP heat-up, and during the ensuing lighter load, temperature hold period.

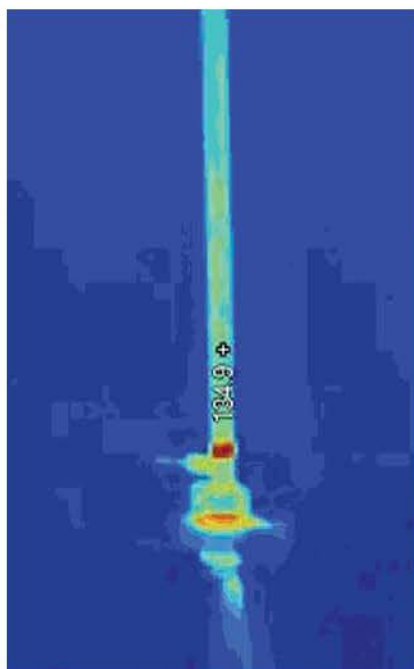

18" 3/4" sanitary tubing downcomer

Infrared photograph of typical 18" downcomer and Steriflow's Sanitary Subcooled Condenser (SSC). Greater heat transfer capability is clearly evident.

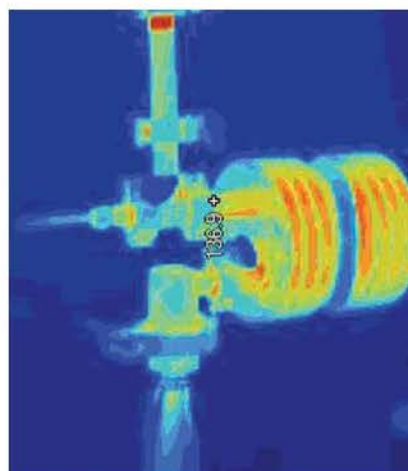

3/4" Steriflow SSC Series

- The large volumetric and cooling capacity of the SSC increases the effectiveness of sanitary steam traps on high load, clean steam applications, such as bioreactor and fermentation vessels.
 - Condensate cooling effectiveness of SSC relative to typical SIP downcomer assemblies:
Average number of °F that condensate is cooled between inlet and outlet of device under dynamic load conditions (30 psi saturated steam heat-up, at loads between 50-290 #/hr).

SIP Assembly Construction
18", 3/4" Sanitary Downcomer
SSC

Subcooling measured (°F)
-1.5°F
-31.3°F

FEATURES & BENEFITS

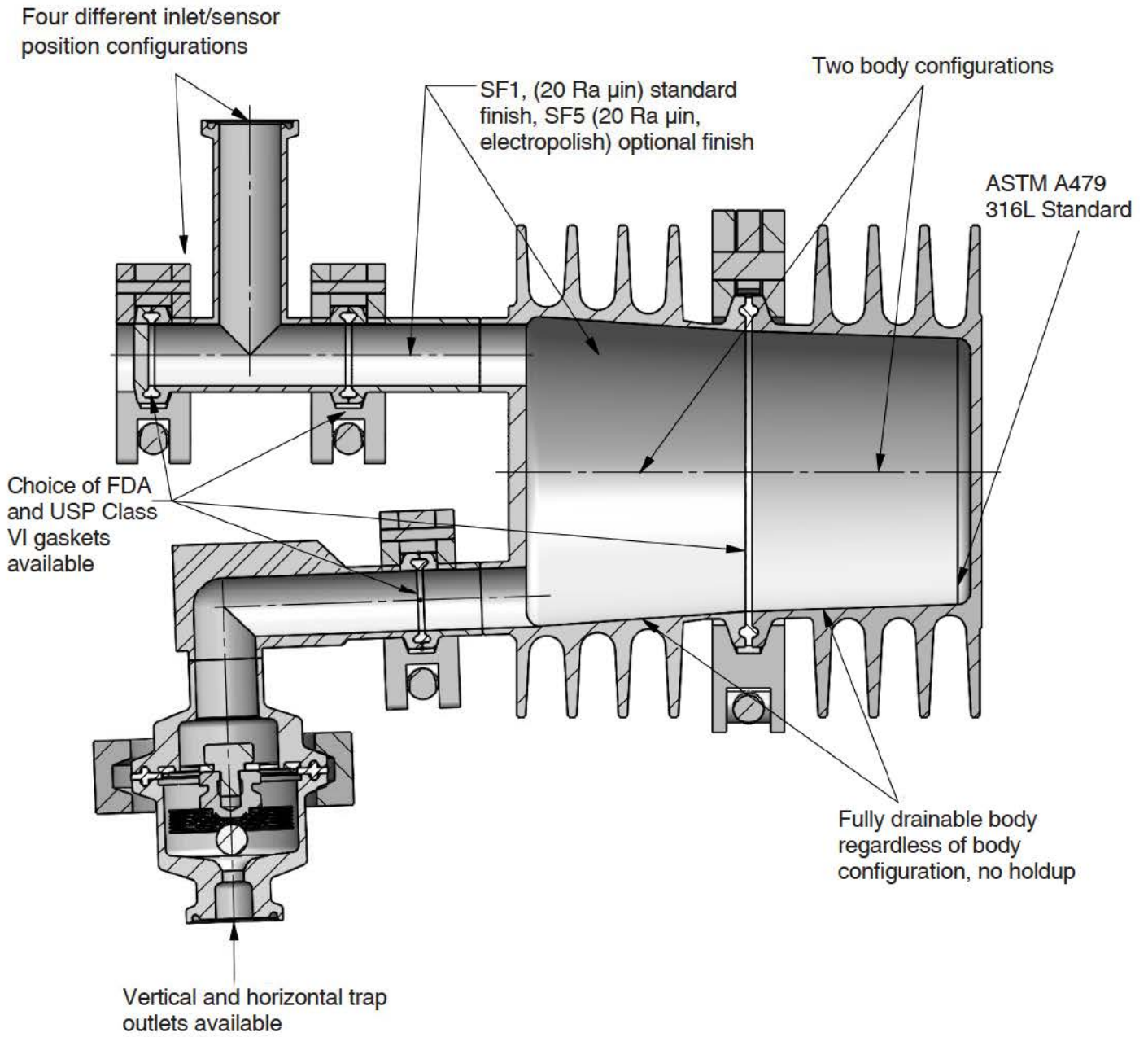

Patent Pending

INSTALLATION & DIMENSIONS

Horizontal Inlet, No Sensor, Two-body Segments, Model SSC-075-HN2...

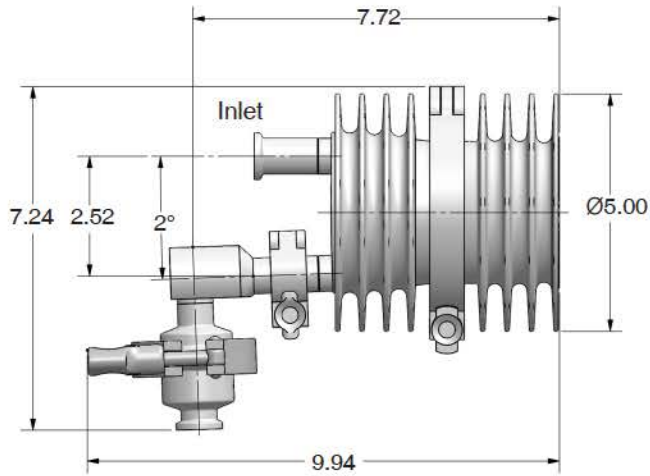

Horizontal Inlet, Sensor, Two-body Segments, Model SSC-075-HS2...

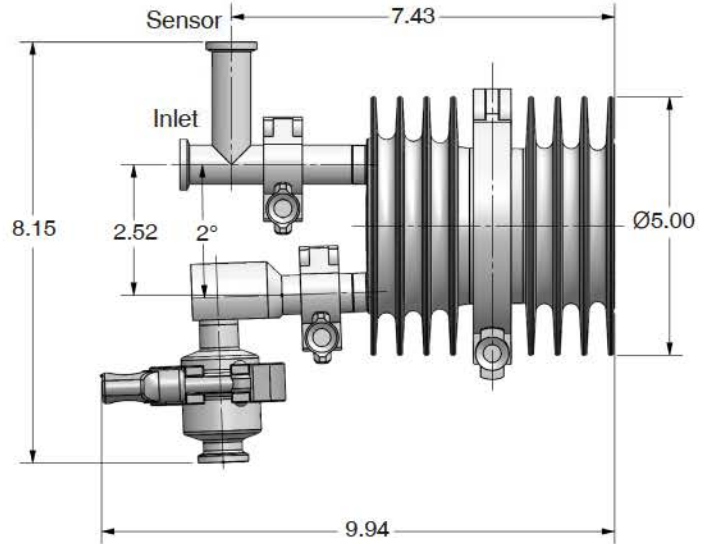

Horizontal Inlet, No Sensor, One-body Segment, Model SSC-075-HN1...

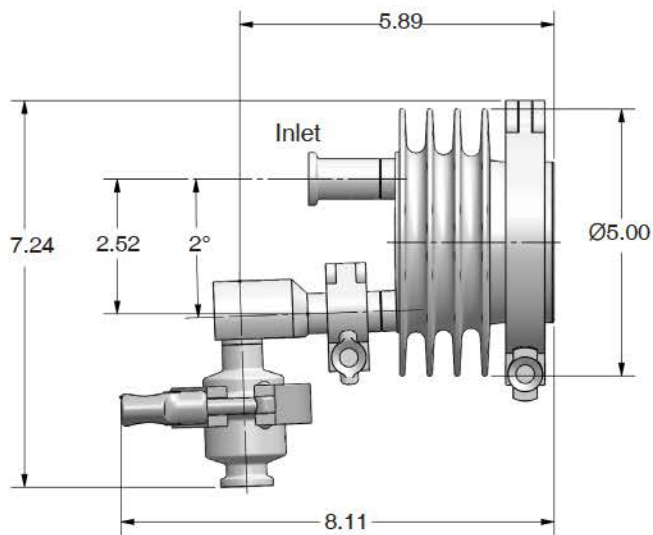

Horizontal Inlet, Sensor, One-body Segment, Model SSC-075-HS1...

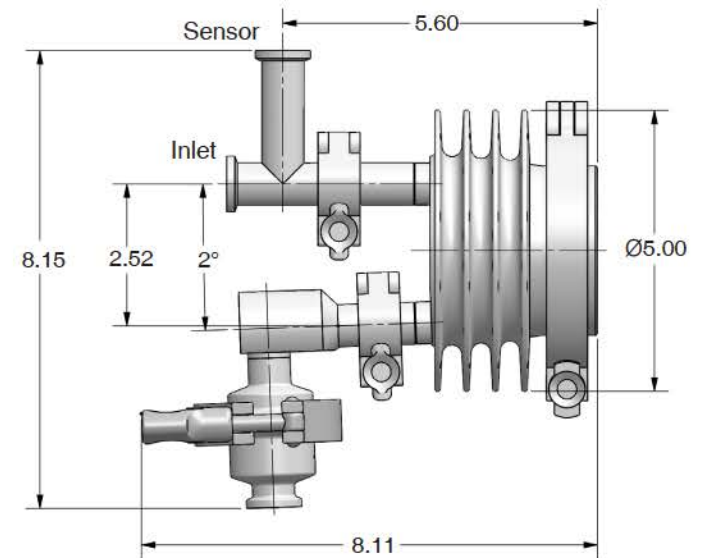

INSTALLATION & DIMENSIONS

Vertical Inlet, No Sensor, Two-body Segments, Model SSC-075-VN2...

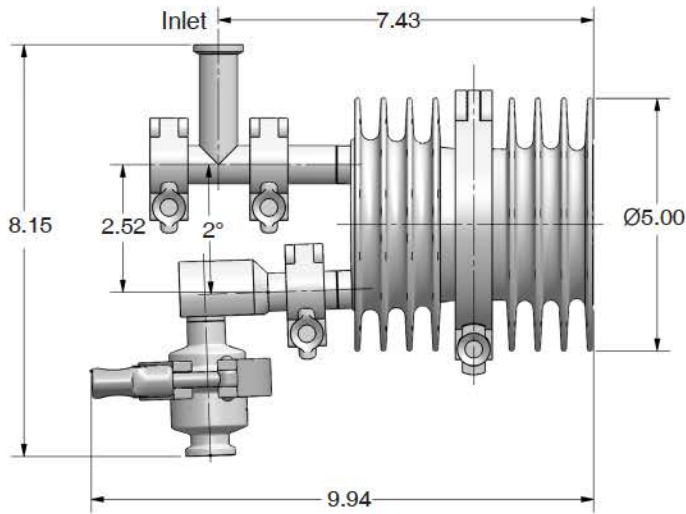

Vertical Inlet, Sensor, Two-body Segments, Model SSC-075-VS2...

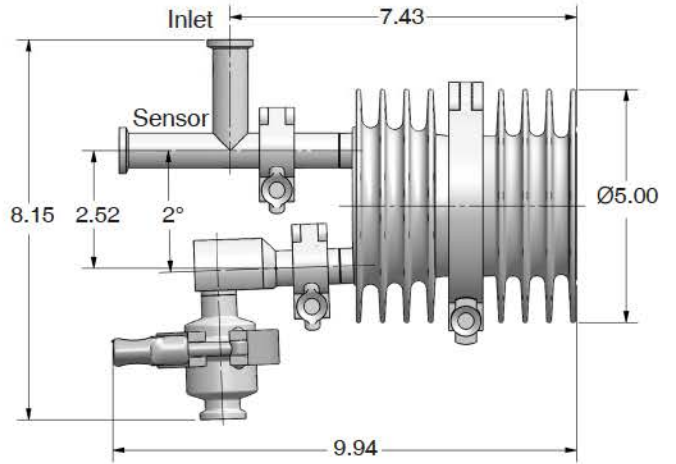

Vertical Inlet, No Sensor, One-body Segment, Model SSC-075-VN1...

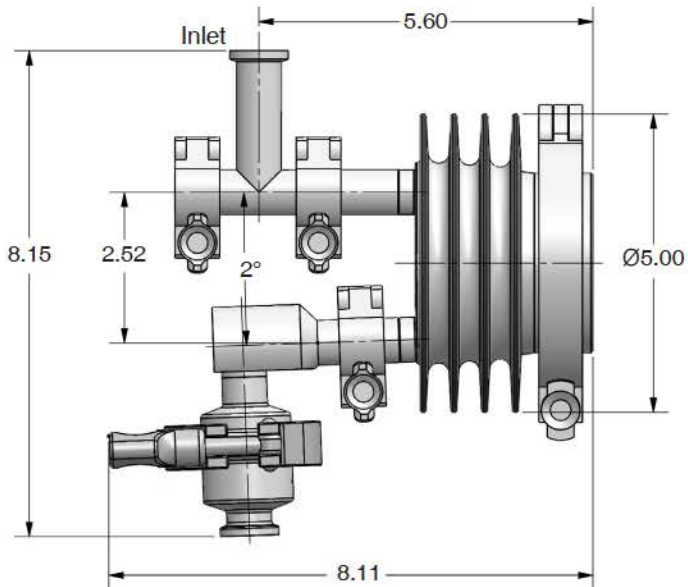

Vertical Inlet, Sensor, One-body Segment, Model SSC-075-VS1...

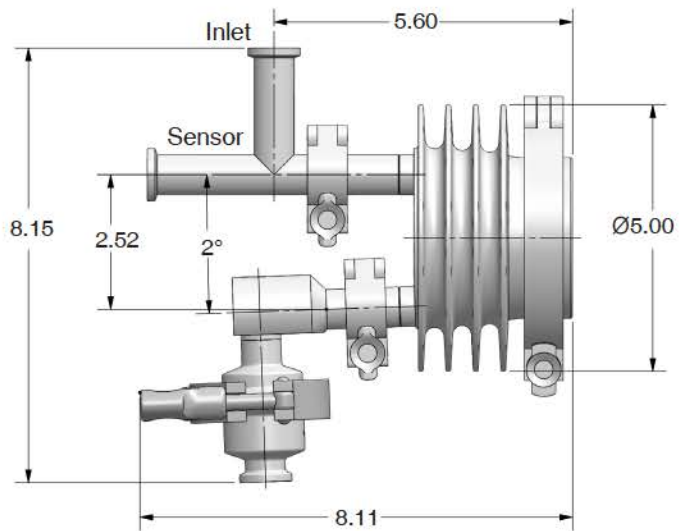

ORDERING SCHEMATIC – SSC SERIES

How to Order

To maximize your savings on temperature validated SSC assemblies, order your SIP temperature sensor and clean steam block valve, or check valve, with the SSC/steam trap assembly on one purchase order. We will purchase your specified components, assemble them to the SSC and bag the assembly for shipment with your installation drawings for shipment directly to your job site. To that end, we have made provisions in the SSC model code for your specified components.

Note: Solid Work files (version 2008) of your chosen SSC assembly (with trap) can be emailed to your process design team so that they can incorporate your chosen SSC configuration into your installation details.

1. **Select your SSC model using the model schematic below.**
2. **Select the steam trap model from the steam trap ordering grid on the next page. Note that you will have to include that model and price on your RFQ or order.**
3. **Include quantity and model information for any temperature sensor valve you require on a separate line item on your RFQ or order.**

Model	—	Size	—	Orientation	Sensor	Body Segment	Gasket	Acc. #1	Acc. #2	Acc. #3
-------	---	------	---	-------------	--------	--------------	--------	---------	---------	---------

Model	
SSC	Standard

Size	
075	3/4" (DN20)

Orientation	
H	Horizontal Inlet
V	Vertical Inlet

Sensor	
N	No Sensor connector needed
S	Sensor connector needed

Body Segment	
1	One Body Segment Assembly
L	Electropolish One Body Segment Assy
2	Two Body Segment Assembly
J	Electropolish Two Body Segment Assy

Gasket	
0	Standard, TFE/Viton Gasket
G	TFE/SST Gasket
L	TFE/SST Gasket & Bolted Clamp
S	Silverback Gasket

Accessory #1	
0	None
S	Assemble to Mark 93 Steam Trap

Accessory #2	
0	None
T	Assemble to Temperature Probe*

Accessory #3	
0	None
B	Assemble to a valve*

* See "How to Order" above

ORDERING SCHEMATIC – MARK 93 SERIES (FOR ASSEMBLY TO SSC)

NOTE: If ordering a 1/2" or 3/4" MK93 with horizontal connections to replace a previous purchase, or ordering an identical model for a new process, PLEASE NOTE THAT THE LAY-IN DIMENSIONS CHANGED IN 2014. Call Steriflow, or your Steriflow representative if you have questions.

Model	Body	Size	End Connections	Special Options
93	C	050	C	P

1	Model/Body Joint
93C	Tri-Clamp Body/Wingnut Clamp
93B	Bolted Body
93K	Tri-Clamp Body/Bolted Clamp
93W	Compact, Welded Body

2	Size
050	1/2" DN15
075	3/4" DN20
100*	1" DN25
150*	1-1/2" DN40

* Note: 1" and 1-1/2" (DN25, DN50) tubing size is generally used in higher condensate load applications. Make sure you check the capacity chart on page 3 to ensure the MK93 can handle your condensate load. If not, the MK94 or MK934 may be a more appropriate model choice.

4	Options
E	TFE/EPDM, FDA USP Class VI
G	Tuf-Steel, TFE/SST Body Gasket, FDA USP Class VI
S	Silverback Gasket TFE/SST Body Gasket, USP Class VI
P ¹	High Pressure Bellows
L	Electropolish MK93C or K Body
R	Electropolish, MK93B Bolted Body
F7*	TFE/Viton FDA, USP Class VI @ 250°F (121°C)

1 For applications with inlet pressure > 45 psi (3 bar)

* Document Part #25384 required when ordering

Note: if no gasket is specifically requested, a TFE/Viton gasket is provided

3		End Connections			
Inlet		Outlet			
C		Inch Tri-Clamp Vertical Inlet/Outlet			
S ^v		ISO Tri-Clamp Vertical Inlet/Outlet			
D ^{****}		DIN Tri-Clamp Vertical Inlet/Outlet			
N		NPT Threaded Inlet/Outlet			
B		BSPT Threaded Inlet/Outlet			
T		Inch Tube Vertical Inlet/Outlet			
M ^{**}		DIN Tube Vertical Inlet/Outlet			
P ^{***}		ISO Tube Vertical Inlet/Outlet			
Z		Non-Standard			
C	H	C	H	Inch Tri-Clamp Horizontal Inlet/Outlet*	
C	H	C	V	Inch Tri-Clamp Horizontal Inlet/Vertical Outlet*	
C	V	C	H	Inch Tri-Clamp Vertical Inlet/Horizontal Outlet*	
M	H	M	H	Din Tri-Clamp Horizontal Inlet/Outlet	
M	H	M	V	Din Tri-Clamp Horizontal Inlet/Vertical Outlet	
M	V	M	H	Din Tri-Clamp Vertical Inlet/Horizontal Outlet	
P	H	P	H	ISO Horizontal Inlet/Outlet	
P	H	P	V	ISO Horizontal Inlet/Vertical Outlet	
P	V	P	H	ISO Vertical Inlet/Horizontal Outlet	

- * Not available on 93W compact welded body
- ** According to DIN 11866
- *** According to ISO DIN 11866 line B, ISO 1127
- **** According to DIN 32676 Row A
- ^v According to DIN 32676 Row B

Note: Horizontal connection: trap lay-in dimension changed in 2014

Please refer to the Mark 93 Series brochure for non SSC applications



Steriflow, a division of Jordan Valve
 3170 Wasson Road • Cincinnati, OH 45209
 513.533.5600 • 800.543.7311 • 513.871.0105 (f)
 steriflow@richardsind.com • www.steriflowvalve.com

Steriflow Valve reserves the right to make revisions to its product, specifications, literature and related information without notice. Please visit our website at www.steriflowvalve.com for the latest information on our products.