

Mark 95 Series

Sanitary Back Pressure Regulators

The Mark 95 is available with a hard or soft seat and a variety of diaphragm and o-ring materials, making the valve well-suited for virtually any sterile back pressure application.

The Mark 95 operates by sensing the inlet pressure, or back pressure, beneath the diaphragm, as flow enters from inlet port on the side. As the back pressure exceeds the setpoint, the diaphragm force compresses the range spring permitting the stem to move from the seat toward the open position. As the flow increases, the back pressure is relieved and the spring and diaphragm relax, allowing the stem to return to the normally closed position. If a different set point is desired, a simple turn of the adjusting screw will increase or decrease the setting to any set point within the range covered by the regulator's spring.



FEATURES

- **New!** DIN & ISO Tri-Clamp and tube weld ends - available as options
- **New!** Optional integral gauge port
- CRN Registration Number Available
- Soft seat capability for ANSI Class VI shutoff
- No guiding surfaces in the fluid – prevents particulate generation
- 100% 316L barstock body and trim
- Self-draining
- No threads to disassemble for cleaning
- Clean-in-Place, Steam-in-Place – dome features spring arrangement to allow CIP/SIP
- Remote setpoint capability
- Lifetime warranty on Jorlon diaphragm

DOCUMENTATION

The following documentation is shipped with each order:

- Steriflow Unicert
 - Traceable Material Heat Number for body and ferrules
 - Certificate of Compliance to FDA and USP Class VI

Certificate of Surface Finish

- Final Test Reports and Certificate of Origin available upon request at time of order

AVAILABLE FINISHES (MK95/MK95FT)

Body

- **Standard:** 20 Ra μin (0,5 Ra μm) (ASME BPE SF5) mechanical finish and electropolish on inside wetted surfaces; machine finish and electropolish on exterior.
- **Optional:** 20 Ra μin (0,5 Ra μm) SF5 mechanical finish and electropolish on external surfaces; 8 Ra μin (0,2 Ra μm) finish on internal or external finishes and electropolish (Better than SF4)

Spring Housing and Handle

- **Standard:** machine finished 316SST, electropolished
- **Optional:** 20 Ra μin (0,5 Ra μm) mechanical finish and electropolish on external surfaces (SF5). 8 Ra μin (0,2 Ra μm) finish on external surfaces on all sizes and electropolish. (Better than SF4)

Adjusting Screw

- **Standard:** 32Ra μin electropolished (Note: adjusting screw is a threaded part)
- **Optional:** 20 Ra μin (0,5 Ra μm) mechanical finish and electropolish finish (SF5)

SPECIFICATIONS – O-RING DIAPHRAGM

Sizes: 1/2", 3/4", 1", 1-1/2" 2", 3"; DIN DN15, DN20, DN25, DN40, DN50, DN80; ISO DN15, DN20, DN25, DN40, DN50, DN80

End Connections

- ASME Tri-Clamp
- ASME Tube Weld Ends
- DIN/ISO Tri-Clamp Conn's to DIN 32676 Row A, B
- DIN/ISO Tube Weld Ends to DIN 11866 Row A, B
- Gauge Port - ASME BPE Tri-clamp

Body & Trim Materials: 316L Stainless Steel (ASTM A47, S31603)

Seat Materials

- Standard hard seat – integral 316L SST seat
- Optional soft seat (for Cv 1.5, 1" size and above)
 - Jorlon (FDA & USP Class VI) for steam and hot fluid service to 338°F (170°C)
 - PEEK (FDA & USP Class VI) for steam and hot fluid service to 350° (177°C)
 - PTFE to +252°F (122°C) continuous or 275°F (135°C) intermittent [not to exceed 15 min. in a one hour period] FDA, USP Class VI

Note: consult factory for 1/2" & 3/4" soft seat materials

Spring Housing Materials

- CF8M cast SST (1/2" – 1") (DN15 - DN25)
- Fabricated 316L SST (1-1/2" – 3") (DN50 - DN80)

Diaphragm Materials

- 316L SST
- EPDM/Nylon (to 275°F, 135°C), FDA only
- Jorlon (to 400°F, 204°C), FDA, USP Class VI
- Ultra-thin Jorlon (to 400°F, 204°C), FDA, USP Class VI (for use with 3-8 range spring only)

O-Ring Materials

- EPDM (to 275°F, 135°C) - FDA, USP Class VI
- Buna-N (to 225°F, 107°C) - FDA
- Viton (to 400°F, 204°C) - FDA, USP Class VI
- Silicone (to 400°F, 204°C) - FDA, USP Class VI
- Teflon-Encapsulated Viton (to 400°F, 204°C) - FDA, USP Class VI)
- Teflon-Encapsulated Silicone (to 400°F, 204°C) - FDA, USP VI*. This o-ring material was limited to certain sizes on older Mark 95's. If a replacement is needed, give us the original serial number.

* For use on new valve size 1-1/2" - 3" only. Can be sold as part of a complete stem/diaphragm/o-ring repair kit on Cv>4.5 only

Shutoff: ANSI Class III hard seat or Class VI soft seat
Body Pressure Temperature Rating: (dependent upon construction)

Valve Size	PSIG @ 100°F	PSIG @ 450°F
1/2", 3/4", 1", DN15, DN20, DN25	350 (24,1 bar)	250 (17,2 bar)
1-1/2", 2", 3", DN40, 50, 80	200 (13,8 bar)	200 (13,8 bar)

Pressure on 1/2", 3/4" & 1" size limited to 225 psig (15,5 bar) @ 100°F and 200 psig (13,8 bar) @ 400°F if using Ultra-thin Jorlon diaphragm.

Set Point Spring Ranges PSI (Bar)		
1/2"-1"	1 1/2"	2"-3"
3-8* (0,2-0,5)	3-25** (0,2-1,7)	5-25 (0,34-1,7)
5-30 (0,34-2,1)	10-25 (0,7-1,7)	10-25 (0,7-1,7)
15-50 (1,0-3,4)	15-40 (1,0-2,7)	15-60 (1,0-4,1)
35-90 (2,4-6,2)	35-85 (2,4-5,8)	
50-105 (3,4-7,2)		

* Ultra thin Jorlon***, or EPDM Diaphragm only

** EPDM Diaphragm only

*** Ultra thin Jorlon available for 1/2" -1" valves only

Cv (Kv) Ratings:

Valve Size	Available Cv (Kv)	Cv for Relief Valve Sizing
1/2", DN15 3/4**** DN20	1.5 (1,3)	3.8 (3,27)
1**** DN25	1.5, 2.5, 4.5, 5.5** (1,3; 2,2; 3,9; 4,7)	10.7 (9,2)
1-1/2" DN40	4.5 or 10.0 (3,9 or 8,6)	6.7 (5,76); 26.3 (22,6)
2" DN50	10.0 or 19.0 (8,6 or 16,3)	16.5 (14,2), 56.5 (48,6)
3" DN80	10.0 or 28.0 (8,6 or 24,1)	16.5 (14,2); 67.1 (57,7)

** Not available with metal diaphragms, Jorlon and other elastomers acceptable

*** When using the 3-8 range spring the following sizing limits apply:

Maximum Allowable Pressure Differential: 200 psi (3-8 spring range has a max of 40 psi)

FEATURES & BENEFITS

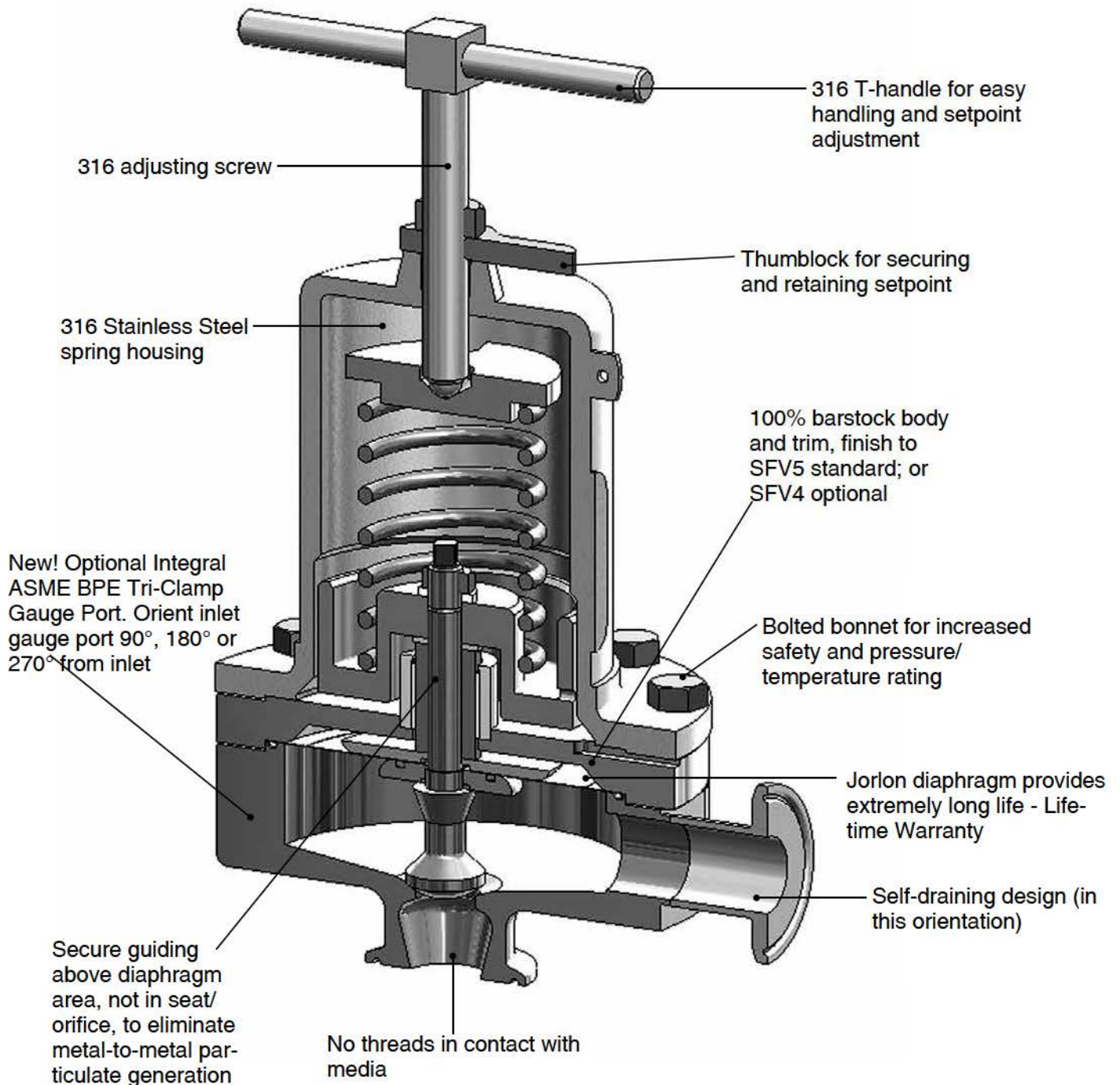

APPLICATIONS

The MK95 is suitable for a variety of process and clean utility applications in the biopharmaceutical, semi-conductor, and food & beverage industries including: continuous circuit WFI pump deadhead diversion, bioreactor agitator seal pressure maintenance, large volume fill back pressure release, and zero dead leg pressure relief.

MARK 95 SERIES SANITARY BACK PRESSURE REGULATORS

DIMENSIONS

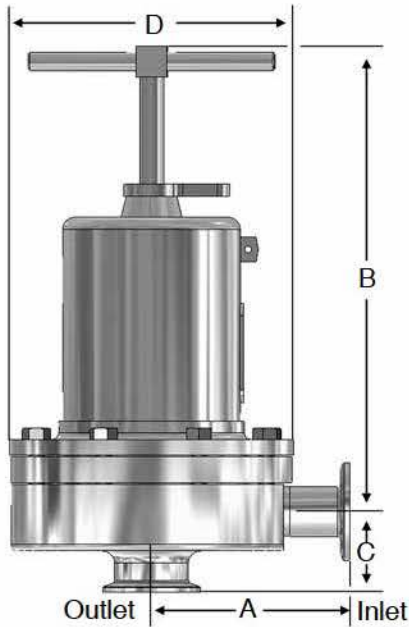

• ASME Tri-Clamp Ends

Valve Size	Dimensions (inches)				Weight Lbs
	A	B	C	D	
1/2"	3.29	8.00	1.37	5.75	18
3/4"	3.29	8.00	1.50	5.75	18
1"	4.00	8.00	1.64	5.70	20
1-1/2"	4.21	10.50	2.53	7.25	40/28.7*
2"	5.34	17.50	2.96	9.50	90/66**
3"	5.34	18.00	3.46	9.50	98

• ASME Tri-Clamp Ends, mm

Valve Size	Dimensions (mm)				Weight Kgs
	A	B	C	D	
1/2"	83,6	203	34,8	146,1	8
3/4"	83,6	203	38,1	146,1	8
1"	101,6	203	41,7	146,1	9
1-1/2"	106,9	267	64,3	184,2	18/13*
2"	135,6	445	75,2	241	41/30**
3"	135,6	457	87,9	241	44

• ASME Tube Weld Ends, inches

Valve Size	Dimensions (inches)				Weight Lbs
	A	B	C	D	
3/4"	3.32	8.00	1.88	5.75	18
1"	3.34	8.00	2.18	5.75	20
1-1/2"	4.68	10.50	3.67	7.25	40/28.7*
2"	5.34	17.50	2.96	9.50	90/66**
3"	5.34	18.00	3.46	9.50	98

• ASME Tube Weld Ends, mm

Valve Size	Dimensions (mm)				Weight Kgs
	A	B	C	D	
3/4"	84,3	203	47,8	144,8	8,2
1"	84,8	203	55,4	144,8	9,1
1-1/2"	118,9	267	93,2	184,2	18/13*
2"	135,6	444	75,2	241	41/30**
3"	135,6	457	87,9	241	44

• DIN Tri-Clamp Connections to DIN 32676 Row A

Valve Size	Dimensions (mm)				Weight Kgs
	A	B	C	D	
15	100,3	203,2	63,6	146,1	8,1
20	99,7	203,2	70,2	146,1	8,1
25	99,7	203,2	72,8	146,1	9,1
40	118,3	266,7	83,6	183,4	18/13*
50	145,8	444,5	93,9	240,5	41/30**
80	146,6	457,2	105	240,5	44,4

• DIN Tube Weld Ends to DIN 11866 Row A

Valve Size	Dimensions (mm)				Weight Kgs
	A	B	C	D	
15	93,4	203,2	56,7	146,1	8,1
20	92,8	203,2	63,3	146,1	8,1
25	92,8	203,2	65,9	146,1	9,1
40	111,4	266,7	76,7	183,4	18/13*
50	138,9	444,5	87	240,5	41/30**
80	139,7	457,2	98,1	240,5	44,4

• ISO Tri-Clamp Connections to DIN 32676 Row B

Valve Size	Dimensions (mm)				Weight Kgs
	A	B	C	D	
15	92,1	203,2	62,5	146,1	8,1
20	92,1	203,2	62,5	146,1	8,1
25	92,1	203,2	65,3	146,1	9,1
40	110,6	266,7	76,8	183,4	18/13*
50	138,2	444,5	93,9	240,5	41/30**
80	138,9	457,2	96,8	240,5	44,4

• ISO Tube Weld Ends to DIN 11866 Row B

Valve Size	Dimensions (mm)				Weight Kgs
	A	B	C	D	
15	92,1	203,2	62,5	146,1	8,1
20	92,1	203,2	62,5	146,1	8,1
25	92,2	203,2	65,3	146,1	9,1
40	110,6	266,7	76,8	183,4	18/13*
50	138,2	444,5	93,9	240,5	41/30**
80	138,9	457,2	96,8	240,5	44,4

* 40 lbs (18,1 kgs) std; 28.7 lbs (13 kgs) with aluminum spring housing

** 90 lbs (40,7 kgs) std; 66 lbs (33 kgs) with aluminum spring housing

GAUGE PORT CONFIGURATION OPTIONS

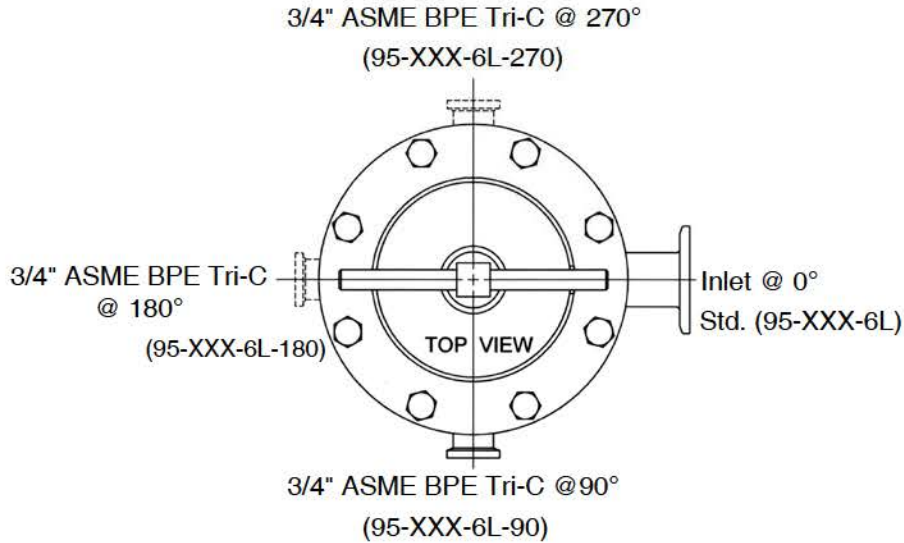

SAMPLE SPECIFICATION

Stainless steel sanitary back pressure regulator body and wetted components shall be made from 316L, ASTM A479, S31603 barstock material. Regulator shall be activated by FDA approved, USP Class VI certified Jorlon diaphragm with lifetime guarantee. All guiding of valve stem/plug shall be outside of the wetted, process areas, above diaphragm. Regulator shall be free of threads within wetted, process areas of valve internal and shall be self draining when installed with outlet vertical and below valve assembly.

Mark 95FT Series

CRN Registration Number Available

Sanitary "Flow Through" Back Pressure Regulators

Starting with the features and benefits associated with the superior design of the Mark 95, Steriflow Valve has added a flow-through option that creates more application potential. The MK95FT can eliminate a portion of the by-pass line components by allowing the back pressure regulating valve to be installed in the primary line – not in the separated by-pass line.

The Mark 95FT is often found in liquid services such as WFI loops, CIP lines and filling lines. The valve is normally closed, allowing flow to pass straight through to downstream users. When demand downstream is reduced and pressure builds and reaches the setpoint, the Mark 95FT will open to relieve and maintain constant pressure. This design allows for elimination of pipe "T"s and elbows, reduction of weld joints, simplified by-pass piping and easier, quicker installation. Due to the unobstructed flow path through the valve, very little to no pressure loss through the valve can be expected. This is a key reason the MK95FT can be installed directly into the primary process piping.

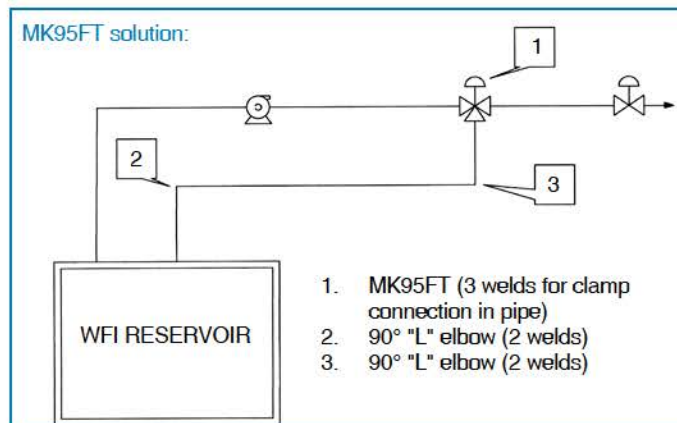
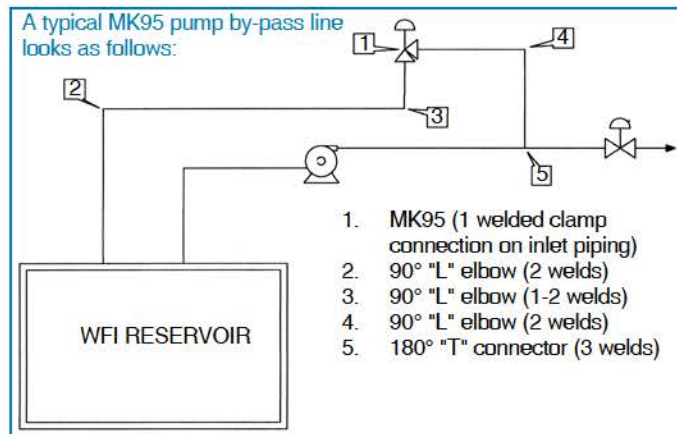
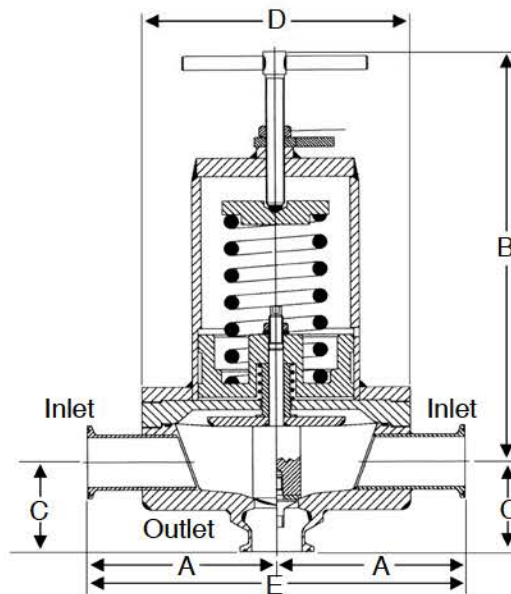

Valve Size	Dimensions (inches)					Weight Lbs
	A	B	C	D	E	
3/4"	3.29	8.50	1.50	5.70	6.58	19
1"	4.00	8.50	1.64	5.70	8.00	21
1-1/2"	4.24	10.5	2.53	7.25	8.48	41
2"	5.34	17.5	2.96	9.50	10.7	91
3"	5.34	18.0	3.46	9.50	10.7	99

Valve Size	Dimensions (mm)					Weight Kgs
	A	B	C	D	E	
DN20	84	216	38	145	168	8,6
DN25	102	216	42	145	203	9,5
DN40	108	267	64	184	214	19
DN50	136	445	75	241	271	41
DN80	136	457	88	241	271	45

Based on US tri-clamp ends. Consult factory for DIN and ISO tri-clamp end dimensions

MARK 95 SERIES SANITARY BACK PRESSURE REGULATORS

ORDERING SCHEMATIC

							1 & 2	3 & 4	5 & 6	7 & 8	9 & 10	11 & 12	13 & 14
--	--	--	--	--	--	--	-------	-------	-------	-------	--------	---------	---------

	Model
95	ASME BPE Tri-Clamp Connections
95T	ASME BPE Tube Weld Ends
95D	DIN Tri-Clamp Conn's to DIN 32676 Row A
95DT	DIN Tube Weld Ends to DIN 11866 Row A
95S	ISO Tri-clamp Conn's to DIN 32676 Row B
95ST	ISO Tube Weld Ends to DIN 11866 Row B
95FT	Flow-Through with ASME BPE Tri-Clamp Connections

1 & 2	Body	
	Finish	Cvs (Kvs)
A	20Ra Interior/63rms Exterior (Std)	A 0.5 & 1.5 (0,5 & 1,3)
B	20Ra Interior/20Ra Exterior	G 3.0 (2,6)
C	8Ra Interior/63rms Exterior*	H 4.5 (3,9)
D	20Ra Interior/8Ra Exterior	K 5.5 (4,7)
E	8Ra Interior/8Ra Exterior*	M 10.0 (8,6)
F	8Ra Interior/20Ra Exterior*	N 19.0 (16,3)
		P 28.0 (24,1)

* Handle and all external surfaces meet spec per above. The adjusting screw is a threaded part and cannot be polished beyond 20Ra
 Note: These valves are all tri-clamp end connections. Consult factory for other options.

	Size
050	1/2"
075	3/4"
100	1"
150	1-1/2"
200	2"
300	3"
15	DN15
15N*	DN15 Non-standard Face
20	DN20
20N*	DN20 Non-standard Face
25	DN25
40	DN40
50	DN50
80	DN80

* DIN or ISO tri-clamp face not conforming to DIN standard 32676. State face size as noted on P.O.

3	Trim Finish
A	20Ra (Standard)
B	8Ra

4	Trim – Cv (Kv) & Seat		
5	0.5 (0,4) Hard Seat	N	5.5 (4,7) Jorlon Seat
A	1.5 (1,3) Hard Seat	P	10 (8,6) Hard Seat
E	3.0 (2,6) Hard Seat	Q	10 (8,6) Teflon Seat
F	3.0 (2,6) Teflon Seat	R	10 (8,6) Jorlon Seat
G	3.0 (2,6) Jorlon Seat	S	19 (16,3) Hard Seat
H	4.5 (3,9) Hard Seat	T	19 (16,3) Teflon Seat
J	4.5 (3,9) Teflon Seat	U	19 (16,3) Jorlon Seat
K	4.5 (3,9) Jorlon Seat	V	28 (24,1) Hard Seat
L	5.5 (4,7) Hard Seat	W	28 (24,1) Teflon Seat
M	5.5 (4,7) Teflon Seat	X	28 (24,1) Jorlon Seat

	Body Material
6L	316L

Continued on next page

	Body Configuration - Gauge Port
	Leave blank for standard
90	3/4" ASME BPE Tri-Clamp F/Gauge port @ 90°
180	3/4" ASME BPE Tri-Clamp F/Gauge port @ 180°
270	3/4" ASME BPE Tri-Clamp F/Gauge port @ 270°

ORDERING SCHEMATIC

							1 & 2	3 & 4	5 & 6	7 & 8	9 & 10	11 & 12	13 & 14

5 & 6	O-Ring/Diaphragm
	Cv 0.5 thru 3.0
BS	Buna/SST Dia.
EL	EPDM/EPDM Dia.
ES	EPDM/SST Dia.
SS	Silicone/SST Dia.
TL	Teflon Encap. Silicone/SST Dia. (1-1/2" - 3")
TG	Teflon Encap. Viton/Jorlon Dia.
TE	Teflon Encap. Viton/SST Dia.
VS	Viton/SST Dia.
ZZ	Non-standard

8	Spring Range PSI (Bar)					
	1/2"-1"		1 1/2"		2"-3"	
A*	3-8* (0,2-0,5)	B**	3-25** (0,2-1,7)	F**	5-25** (0,34-1,7)	
D	5-30 (0,34-2,1)	E	10-25 (0,7-1,7)	E	10-25 (0,7-1,7)	
H	15-50 (1,0-3,4)	G	15-40 (1,0-2,7)	J	15-60 (1,0-4,1)	
L	35-90 (2,4-6,2)	K	35-85 (2,4-5,8)			
Q	50-105 (3,4-7,2)					

5 & 6	O-Ring/Diaphragm
	Cv > 3.0
BU	Buna/SST Dia.
EE	EPDM/EPDM Dia.
EP	EPDM/SST Dia.
SL	Silicone/SST Dia.
TS	Teflon Encap. Silicone/SST Dia.*
TY	Teflon Encap. Viton/Jorlon Dia.
TV	Teflon Encap. Viton/SST Dia.
VT	Viton/SST Dia.
ZZ	Non-standard

* Ultra thin Jorlon**, or EPDM Diaphragm only
 ** EPDM Diaphragm only
 *** Ultra thin Jorlon available for 1/2" -1" valves only

9 & 10	Diaphragm
6L	SST (all exterior)
EP	EPDM (all exterior)
JL	Jorlon (all exterior)
UJ	Ultra-thin Jorlon (all exterior)***

*** Ultra thin Jorlon available for 1/2" -1" valves only

* See note on Page 2

7	Adjusting Screw Finish (Except Threads)
A	Electro-polished (Standard)
B	20Ra (SFV5)
C	8Ra

11 & 12	Actuator Finish/Type
AA	Standard
BA	20Ra (SFV5) exterior
CA	8Ra exterior
DA	Electro-polished for 2" & 3"

13 & 14	PED Compliance
00	Not Required
0G	SEP (1/2", 3/4", 1") (DN15-DN25)
FF	CE Category I (1-1/2", 2", 3") (DN40-80)

Steriflow Valve reserves the right to make revisions to its products, specifications, literature, and related information without notice. Please visit our website at www.steriflowvalve.com for the latest information on our products.