



United Air Specialists, Inc.

a CLARCOR company

Model SDB

Downdraft Bench

The heavy-duty SDB Downdraft Bench offers a large work surface, high-capacity dust drawers and a downdraft velocity up to 200 fpm. It is typically used for grinding, polishing, hand sanding and dry buffing.

The SDB bench features an automatic pulse cleaning system with four Advanced Nanofiber Filtration Technology cartridge filters, including an option for flame retardant media. It can support 75 lbs. per square foot on its 80" wide x 55" deep work surface, and comes standard with a 3 HP motor, 230-460/3/60.

Options include special filter media, Photohelic® gage, non-sparking fan wheel and 208/3/60 input voltage.

Standard Features

- Heavy-duty work surface supports 75 lbs./ft²
- Four UAS nanofiber cartridge filters
- Downdraft velocity of 200 fpm
- Magnehelic® gage mounted on unit
- Large capacity dust drawers
- Automatic self-cleaning reverse pulse jet system
- Heavy-duty airfoil fan wheel
- Sound attenuated blower housing
- Quick-release filter access doors
- Powder-coated, scratch-resistant paint

Options & Accessories

- Left- or right-hand side discharge
- Fire-retardant filters
- Fluorescent light fixtures
- Non-sparking fan wheel
- 208 volt
- Four choices of cartridge filter media
- Combination motor starter panel



Applications

- Bulk Powders
- Drilling
- Dry Chemicals
- Carbon Black
- Cast Iron
- Grinding
- Paint Pigment
- Paper Dust
- Spices
- Welding
- Wood Dust

www.uasinc.com
1-800-252-4647

DOWNDRAFT BENCH DUST COLLECTOR

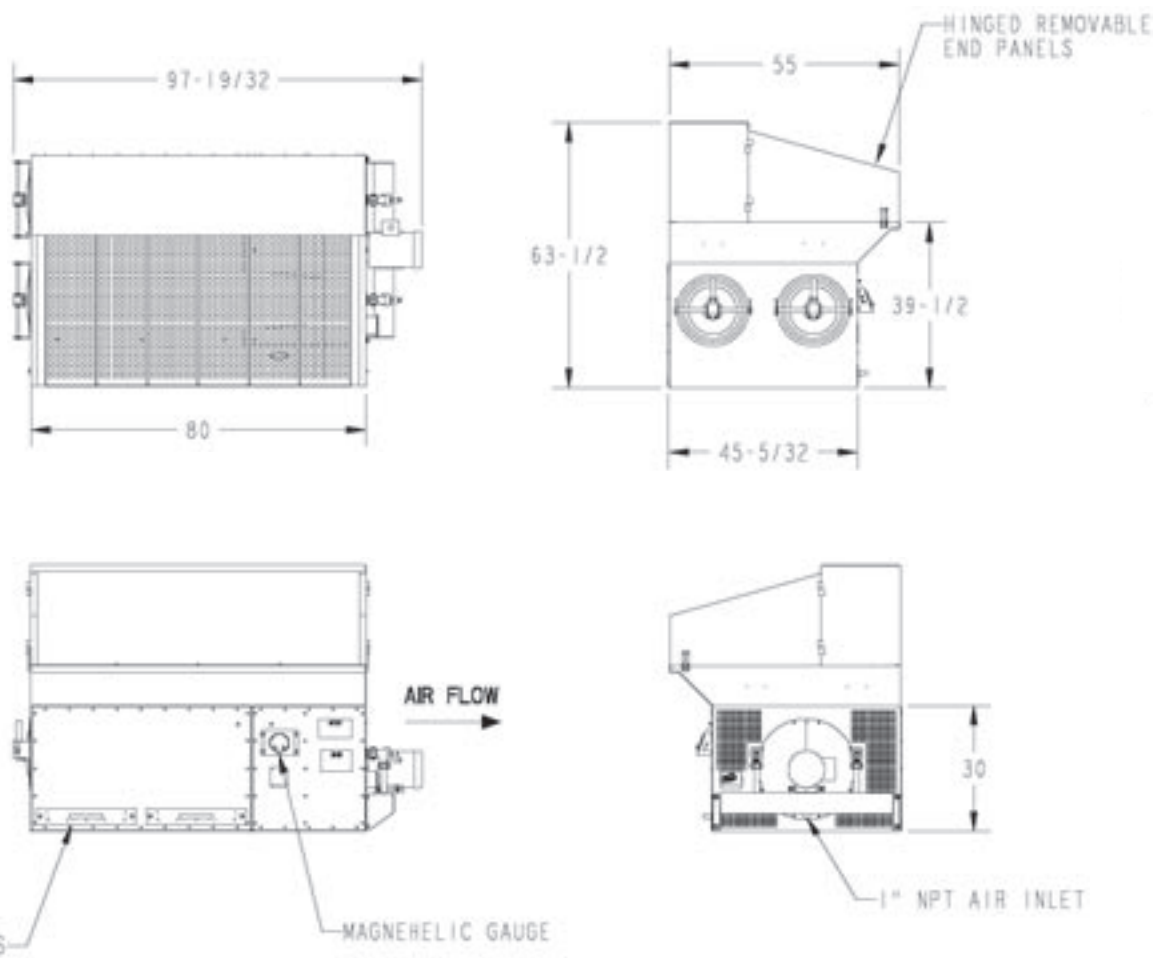

OPTIONS AVAILABLE:

1. SPECIAL FILTER MEDIA AS REQUIRED
2. PHOTOHELIC GAUGE
3. NON SPARKING FAN WHEEL
4. 200 VOLT OPTION - 3 HP TEFC, 200/3/60

FEATURES:

1. LIGHTWEIGHT REMOVEABLE DUST DRAWERS
2. HEAVY DUTY AIRFOIL FAN
3. SOUND ATTENUATED BLOWER HOUSING
4. ACCELERATOR NOZZLES IN BLOWPIPE ASSEMBLY
5. QUICK RELEASE FILTER ACCESS DOORS

SPECIFICATIONS:

POWER:	2500 CFM NOMINAL
TIMER:	3 HP TEFC, 230-460/3/60
ACTUAL FILTER AREA:	115/1/60 STANDARD
NUMBER OF VALVES:	1020 SQUARE FEET
NUMBER OF CARTRIDGES:	2, WITH INTEGRAL PILOTS
APPROX. UNIT WEIGHT:	4 @ Ø13.83 x 26" LONG
COMPRESSED AIR @ 100 psi:	1000 LBS
	0.78 SCF PER PULSE

United Air Specialists, Inc. 4440 Creek Road, Cincinnati, OH 45242, 800-252-4647

UAS, Inc. reserves the right to change design or specifications without notice.

IND-SDB-0807-PRO



Clean air. It's what we do.®

www.uasinc.com