



AIR PRODUCTS AND CONTROLS INC.

RWF DUCT SMOKE DETECTORS

UNIVERSAL VOLTAGE

115 V.A.C., 24 V.A.C., 24 V.D.C.,

PRODUCT APPLICATION

The RWF duct smoke detector provides early detection of smoke and products of combustion present in air moving through HVAC ducts in Commercial, Industrial and Residential applications. The RWF is designed to prevent the recirculation of smoke in areas by the air handling systems, fans and blowers. Complete systems may be shut down in the event of smoke detection.

The RWF Universal Voltage Model will operate on any one of three input voltages (115 V.A.C., 24 V.A.C., or 24 V.D.C.).

PRODUCT DESCRIPTION

Continuing to expand on the reliable design utilized in the previous duct units, the compact RWF contains 2 sets of alarm contacts, namely, 2 sets of form "C" contacts rated at 10amps and 1 set of form "C" 10amp trouble contacts for monitoring detector head removal, and the failure of the input supply voltage.

The green pilot and red alarm visual indicators provided on the front of the RWF duct unit, signal the operating status of the device. The green pilot LED will be extinguished when the detector head is removed. A manual test/reset switch is located along side the visual indicators.

The RWF is designed and built to meet all local requirements, as well as the NFPA regulations regarding duct smoke detectors. Output terminals are provided for remote accessories such as a horn, strobe, remote status indicators and reset key switches or push buttons. The ionization and photoelectric detector heads are interchangeable. Air sampling is accomplished by two tubes which protrude into the duct. An exhaust tube of one standard length (7.5") is supplied in the installation kit with the duct smoke unit. Once the duct width has been determined the air intake sampling tubes must be ordered. Sampling tubes are supplied in three standard lengths 2.5ft, 5.0ft and 10.0ft and cut to size to fit the duct. Mounting the duct smoke unit is accomplished by the use of a template and 4 sheet metal screws, which are provided. Mounting can be achieved without the removal of the clear cover which is secured by 4 capture screws.

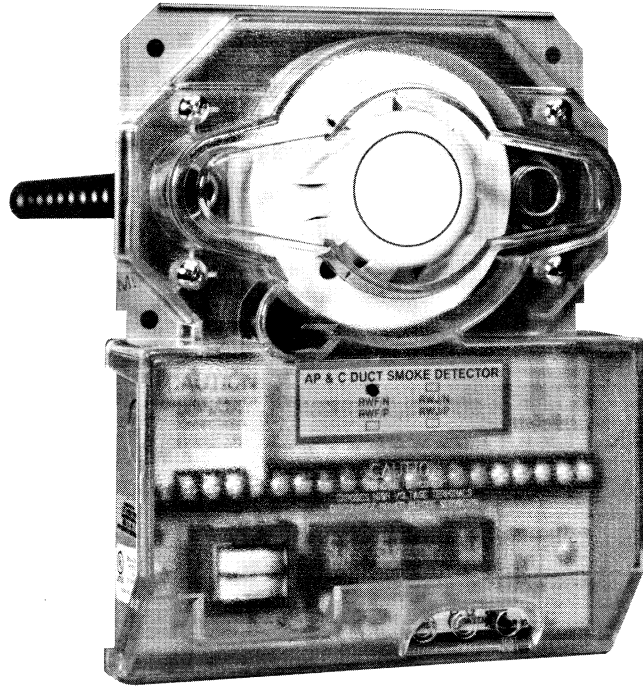

UNDERWRITERS' LABORATORIES LISTED

CSFM Listing No. 3240-1004:105



Made in U.S.A.

MEA No. 73-92-E

Air Products And Controls Inc. Air Products And Controls Inc. Air Products And Controls Inc. Air Products And Controls Inc. Air Products And Controls Inc.

- Operating voltages 115 V.A.C., 24 V.A.C., 24 V.D.C.
- Compact size
- 2 Sets of alarm contacts
- 1 Set of trouble contacts
- Rugged steel backbox with clear cover
- Clear cover fitted with 4 capture screws
- Large terminal connection screws
- Interchangeable "Plug-In" photoelectric or ionization heads
- Compatible with building automation and fire alarm system
- Ease of installation without cover removal (Mechanical)
- Dust filtering Included in detector head
- No additional screens or filters to clean

Air Products And Controls Inc. Air Products And Controls Inc. Air Products And Controls Inc. Air Products And Controls Inc. Air Products And Controls Inc.

Distributed By:

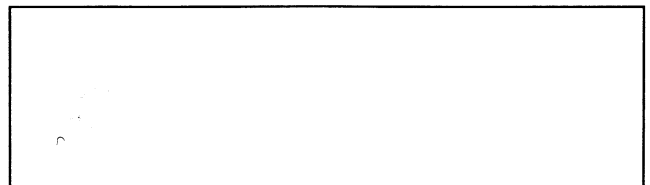

A
HALMA
GROUP
COMPANY

WIRING

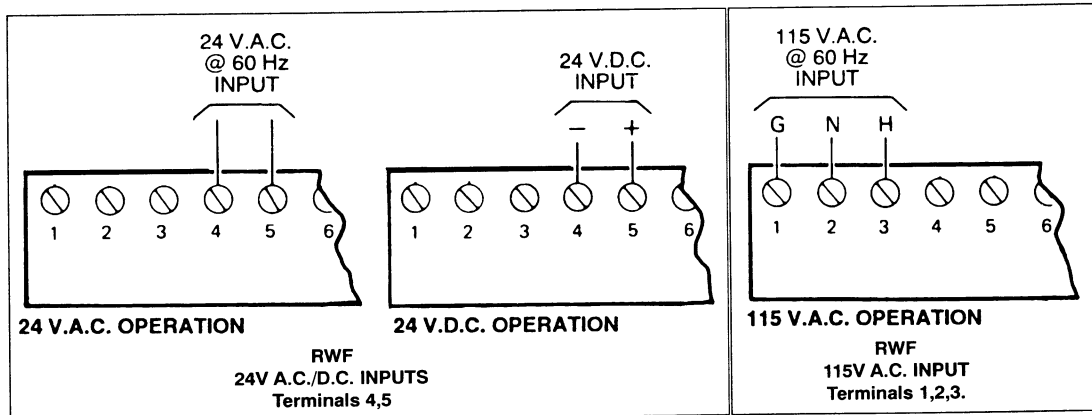
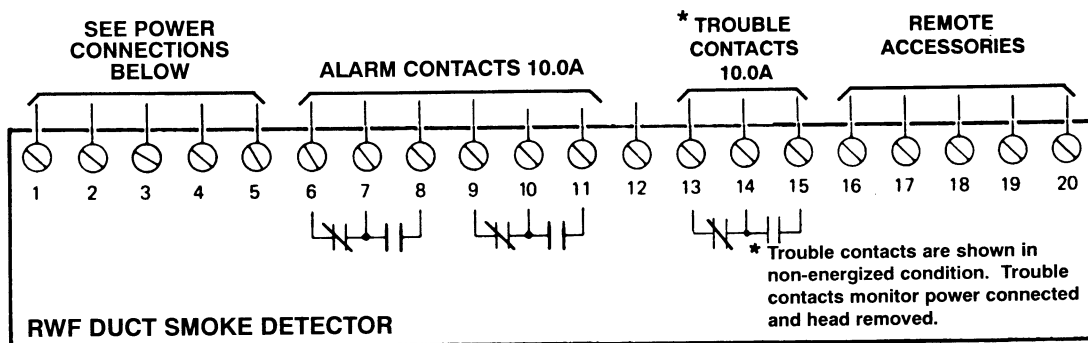

Air Products And Controls Inc. Air Products And Controls Inc. Air Products And Controls Inc. Air Products And Controls Inc. Air Products And Controls Inc.

PRODUCT SPECIFICATIONS

MODEL NUMBER:	RWF - N	115 V.A.C., 24 volt A.C., or 24 volt D.C. Ionization
	RWF - P	115 V.A.C., 24 volt A.C., or 24 volt D.C. Photoelectric
SAMPLING TUBES:	STS-2.5	Sampling tube for 6" to 2.5' duct width
	STS-5.0	Sampling tube for 2.5' to 5.0' duct width
	STS-10.0	Sampling tube for 5.0' to 10.0' duct width
POWER REQUIREMENTS: Quiescent (Without accessories)	115 V.A.C.	14.0 mA
	24 V.A.C.	20.0 mA
	24 V.D.C.	13.0 mA
HEAD IN ALARM:	115 V.A.C.	28.0 mA
	24 V.A.C.	95.0 mA
	24 V.D.C.	62.0 mA
RELAY CONTACT RATING:	Alarm contacts,	2 sets form "C" rated at 10 amps @ 115 V.A.C. Resistive
	Trouble contacts,	1 set form "C" rated at 10 amps @ 115 V.A.C. Resistive
AIR VELOCITY:	300 to 4000 ft./min.	
AMBIENT TEMPERATURE:	32°F to 120°F (0°C TO 49°C)	
HUMIDITY:	10% to 85% R.H. No Condensation	
APPROVAL:	Underwriters Laboratories Listed, (UL268A)	
MATERIAL:	18 G.A. steel backbox, clear plastic cover	
FINISH:	Grey paint	
DIMENSIONS:	L - 9 1/8" X W - 7 1/4" X H - 2 1/4"	
MAX. NET WT.:	3 1/2 LBS	
RADIOACTIVE ELEMENT:	For RWF - N (Ionization) Americium 241; 0.9 Micro-Curie	

Air Products And Controls Inc. Air Products And Controls Inc. Air Products And Controls Inc. Air Products And Controls Inc. Air Products And Controls Inc.

ENGINEERS & ARCHITECTS SPECIFICATIONS

Air duct smoke detectors shall be Air Products And Controls Inc. RW-Series. For ionization detectors the model number is RWF-N, for photoelectric detectors the model number is RWF-P. The detectors shall be listed by Underwriters Laboratories per U.L. 268A. The detectors shall operate at air velocities from 300 feet per minute to 4000 feet per minute.

The duct detector housings shall be of metal construction and complete mechanical installation may be performed without removal of detector cover.

Visual indication of alarm and power must be provided on detector front.

A manual reset switch shall be located on front of the device.

Detector heads shall not require additional filters or screens which must be maintained.

The housing shall contain a detector base which will accept photoelectric or ionization detector heads.

Terminal connections shall be of the screw type and be a minimum of # 6 screw. Terminals shall be provided for remote pilot, remote alarm indication, strobe/horn and remote reset switch. All wiring must comply with local codes and regulations.



AIR PRODUCTS AND CONTROLS INC. INSTALLATION INSTRUCTIONS FOR RWF AND RWJ SERIES DUCT SMOKE DETECTORS

RWF-N or RWJ-N Ionization; 4-WIRE; 24VAC, 24VDC, OR 115VAC
RWF-P or RWJ-P Photoelectric; 4-WIRE; 24VAC, 24VDC, OR 115VAC

PRODUCT OVERVIEW

PRODUCT APPLICATION

RWF/J Series duct smoke detectors provide early detection of smoke and products of combustion present in air moving through an HVAC duct supply, return, or both in commercial, industrial, and residential applications. These devices are designed to prevent the recirculation of smoke in areas by the air handling systems, fans, and blowers. Complete systems may be shut down in the event of smoke detection.

NOTE: For the correct installation of a duct smoke unit, please refer to the NFPA 72 (National Fire Alarm Code), NFPA 90A (Standard for Installation of Air Condition and Ventilation Systems), NFPA 92A (Recommended practice for smoke control systems.), NFPA 5000 (Building Construction and Safety Code), IMC (International Mechanical Code), and IFC (International Fire Code).

This detector is not intended for open area protection nor should it be used for early warning detection or replace a regular fire detection system.

PRODUCT DESCRIPTION

The RWF/J Series smoke detector is fitted with a mounting base that will accept an Apollo Ionization detector head model 55000-225APO (or 55000-250APO) or Photoelectric detector head model 55000-328APO (or 55000-350APO). The duct unit supports 2 sets of form "C" alarm contacts and 1 form "C" trouble contact. The trouble contact supervises the presence of the input power and removal of the detector head.

THE TROUBLE CONTACTS (TERMINALS 13-14-15) ARE SHOWN IN THE NON-ENERGIZED CONDITION. IN NORMAL OPERATION, CONTACTS WILL BE REVERSED.

The trouble contacts **will not** operate in the event of a smoke alarm. The RWF/J Series duct detector will operate from various input voltage sources; namely 24VAC, 24VDC, and 115VAC.

SAMPLING TUBES

The operating principle of a duct detector is based on the Venturi effect. Two tubes extend into the HVAC duct. Air flowing through the duct is forced into the air intake (inlet) tube via the air intake holes, (facing the airflow) and passes over the detector head. The air will be drawn out via the exhaust tube back into the HVAC duct. (A 7" exhaust tube is provided in the installation kit.) When the concentration of smoke particles suspended in the air stream reach the alarm threshold of the detector head, the unit will go into alarm.

The duct smoke detector units are designed to operate in duct widths from 6" to 10' wide with an air velocity between 500 to 4,000 feet per minute. To verify correct installation, the pressure differential between

the sampling (high side) and exhaust (low side) tubes should be measured using a Magnehelic pressure gauge or equivalent. An acceptable reading is between 0.01 and 1.2 inches of water.

To minimize the impact of air turbulence and stratification on performance, a duct smoke detector should be located as far as possible downstream from any obstruction (i.e. deflector plates, elbows, dampers, etc.). In all situations, confirmation of velocity and pressure differential within specifications is required.

REMOTE ACCESSORIES

Audible and visual alarm indicators, remote status indicators, and remote reset/test switches can be accommodated by the RWF/J Series duct units by connecting to DC voltage output terminals 16 through 20. These terminals are not supervised and the voltage/current will only be present when the detector unit is in alarm. The remote pilot (green) LED will be permanently illuminated when connected to the output terminals as long as input power and detector head are present.

RWF/RWJ AT-A-GLANCE

MODEL NUMBER:

RWF-N or RWJ-N 4 Wire Ionization Duct Smoke Detector
RWF-P or RWJ-P 4 Wire Photoelectric Duct Smoke Detector

DETECTOR HEAD MODEL NUMBER:

Ionization Detector Head: **55000-225APO or 55000-250APO**
Photoelectric Detector Head: **55000-328APO or 55000-350APO**

POWER REQUIREMENTS:

QUIESCENT CURRENT		ALARM CURRENT	
24VAC	50mA	24VAC	180mA
24VDC	13mA	24VDC	62mA
115VAC	14mA	115VAC	28mA

RELAY CONTACT RATINGS:

Alarm contacts: 2 Sets form "C" rated at 10A @ 115VAC resistive
Trouble contacts: 1 Set form "C" rated at 10A @ 115VAC resistive
Air velocity: 500 to 4,000ft/min.
Ambient temperature: RWF-N and RWJ-N: 32°F to 158°F (0°C to 70°C)
RWF-P and RWJ-P: 32°F to 100°F (0°C to 38°C)
Humidity: 10% to 85% RH Non-Condensing/Non-Freezing
Material: 18GA steel back box, clear plastic cover (Makrolon 94V-0)
Finish: Gray paint on black box
Dimensions: 9 1/8" L X 7 1/4" W X 2 1/4" H
Max. net wt.: 3 1/2 lbs.
Radioactive element: RWF/J-N (Ionization) - Americium 241, 0.9 micro curie. **Do not expose to corrosive atmospheres.**

MECHANICAL INSTALLATION

LOCATION PREREQUISITES

This guideline contains general information on duct smoke detector installation, but does not preclude the NFPA and/or ICC documents listed. Air Products and Controls Inc. assumes no responsibility for improperly installed duct detectors. To determine the correct installation position for an RWF/J Series duct smoke detector, the following factors must be considered.

- 1) A uniform non-turbulent (laminar) airflow between 500 ft/min. to 4,000 ft/min. must be present in the HVAC duct. To determine duct velocities, examine the engineering specifications that define the expected velocities or use an Anor model 6000AP velocity meter (or equivalent).
- 2) To minimize the impact of air turbulence and stratification on performance, a duct smoke detector should be located as far as possible downstream from any obstruction (i.e. deflector plates, elbows, dampers, etc.). In all situations, confirmation of velocity and pressure differential within specifications is required.

The pressure differential between the input sampling (high pressure) tube and exhaust (low pressure) tube for the RWF/J Series smoke duct detector should be greater than 0.01 inches of water and less than 1.2 inches of water.
- 3) Identify a code compliant location (supply or return side) for the installation of the duct unit that will permit easy access for viewing and serviceability.
- 4) When installing on the return side, install duct units prior to the air being exhausted from the building or diluted with outside "fresh" air.
- 5) When installing duct smoke units down stream of filters, fires occurring in the filters will be detected, but if the filters become blocked, insufficient air flow through the duct unit will prevent the correct operation of the duct detector. Duct units installed in the supply air side may monitor up-stream equipment and/or filters.
- 6) Where possible, install duct detectors upstream of air humidifiers and downstream of dehumidifiers.
- 7) To prevent false alarms, the duct detector should not be mounted in areas of extreme high or low temperatures, in areas where high humidity exists, or in areas where the duct may contain gases or excessive dust.

SAMPLING TUBE ASSEMBLY

Sampling tubes are to be ordered separately in one of four standard lengths.

- STS-1.0** For duct widths of 6" TO 1.0'
- STS-2.5** For duct widths of 1.0' TO 2.5'
- STS-5.0** For duct widths of 2.5' TO 5.0'
- STS-10.0** For duct widths of 5.0' TO 10.0'

Standard sampling tubes are steel tubes with air intake holes drilled the entire length of the tube. These tubes must be cut to length and should span the entire width of the duct. Sampling tubes over 3.0' must be supported on the opposite side of the duct. To ensure the correct operation of the sensing tube, the red end

cap (red stopper in installation kit) must be inserted in the end of the air intake sampling tube. For custom duct widths, always use the next longest standard size and cut down to the exact requirement.

Once the airflow direction has been determined, insert the inlet and exhaust tubes into the sampling tube connectors fitted to the back of the duct smoke detector which are equipped with set screws. These connectors will allow the tubes to be correctly orientated and secured by tightening the set screw. Ensure air intake sampling tube is positioned so that the inlet holes are directly facing the airflow.

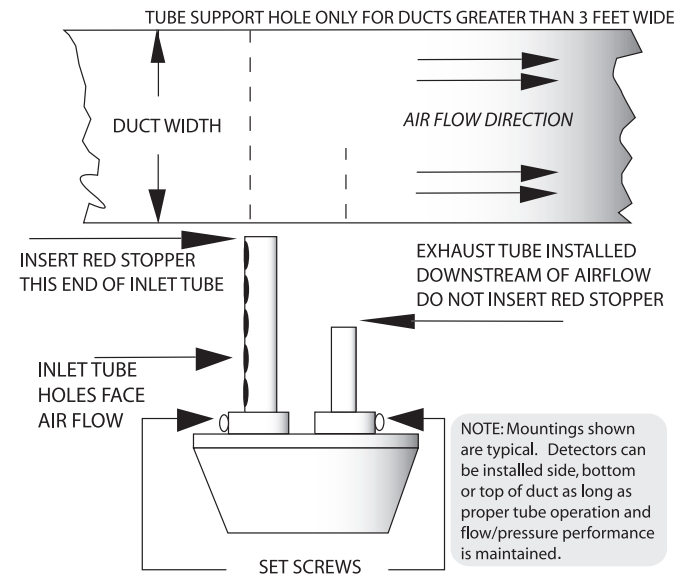

DUCT PREPARATION

Remove mounting template from the installation kit. Remove paper backing from the mounting template and affix it to the duct at the desired location. Using the template as a guide, drill (4) mounting holes (3/32" diam.) for the # 12 X 1/2" sheet metal screws packaged in the installation kit. Drill or punch (2) 1 3/8" holes for inlet sampling and exhaust tubes, using the template as a guide. Clean all holes.

MOUNTING

After securing the sampling and exhaust tubes to the duct smoke unit, (or initially placing the tubes through the 1 3/8" holes drilled or punched in the HVAC duct to accept the inlet sampling and exhaust tubes and then attaching them to the duct unit), hold the duct unit assembly in position and use (4) # 12 X 1/2" sheet metal screws (packaged in the installation kit) to secure the duct smoke detector to the HVAC duct sheet metal.

AIR SAMPLING VERIFICATION

To ensure correct operation of the duct unit use a Magnehelic differential pressure gauge, Dwyer 2000 or 4000 Series (or equivalent) to determine the differential pressure between the inlet (high side) and exhaust (low side) tubes. The differential pressure between the two tubes should be greater than 0.01 inches of water and less than 1.2 inches of water.

ELECTRICAL INSTALLATION

POWER CONNECTIONS

Prior to connecting input power to the duct unit, determine the correct input voltage/ current availability and ensure it is connected to the correct terminals.

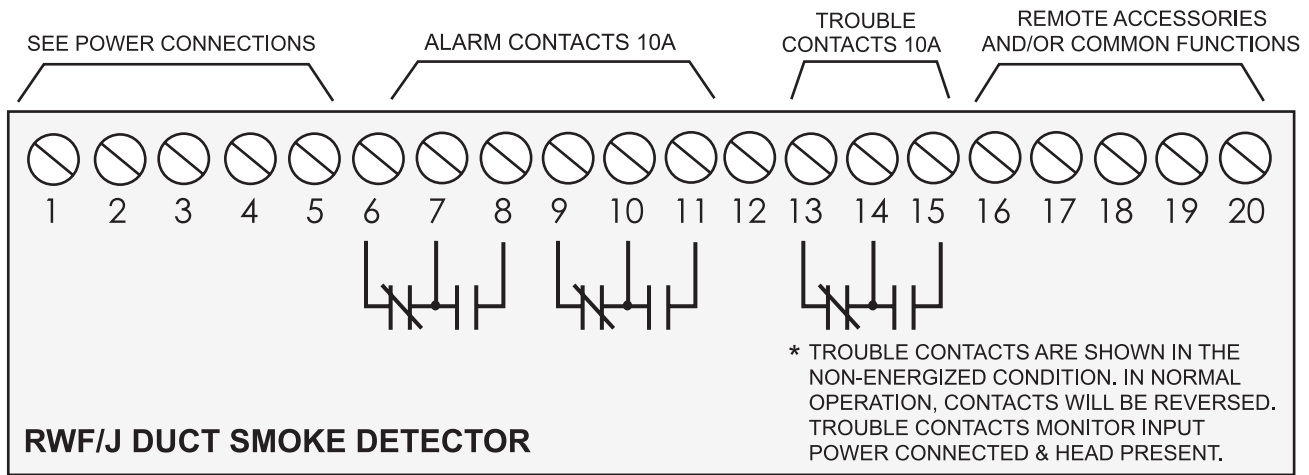
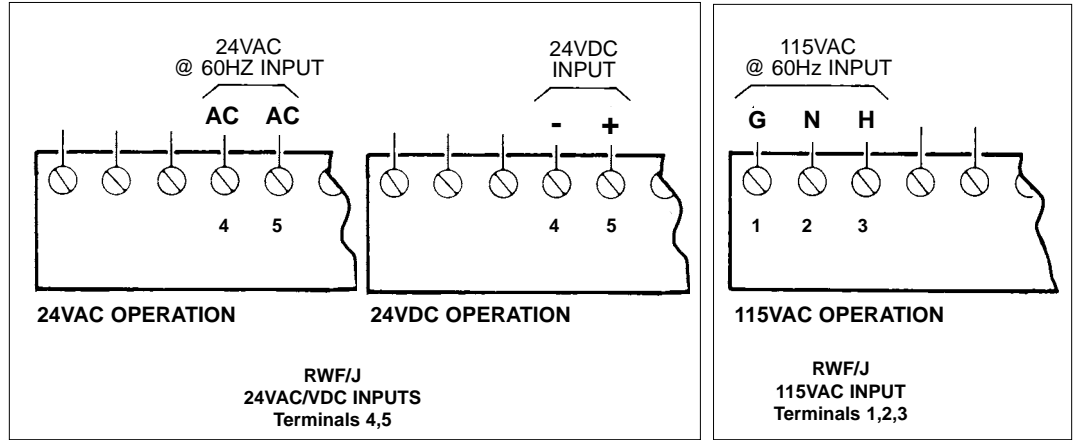

WIRING

CAUTION: For terminals 6-15 do not use looped wire under terminals. Break wire run to provide for proper supervision of connections.

With detector head removed, connect one of the appropriate dedicated power sources to the applicable terminals (see above). Replace detector head and the unit will be energized. The green pilot LED will be illuminated, and when pressing the test/reset button, the red alarm LED will be illuminated. This test confirms the correct basic operation of the duct smoke unit, excluding the detector head (see functional testing).

In the event of a fire alarm, certain equipment may be required to be shut down. For example, shut down may be achieved by interrupting the fan supply source to that particular piece of equipment when wired as indicated below.

EXAMPLE:

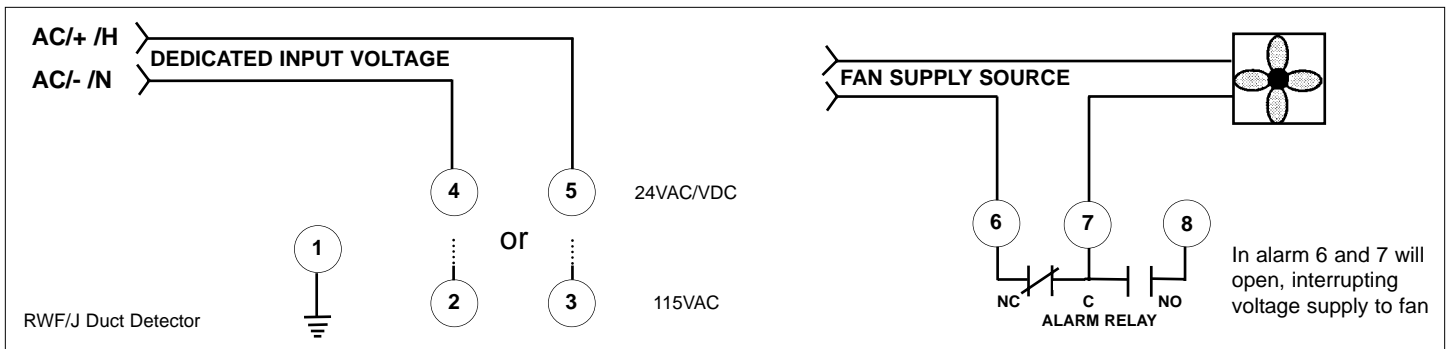

COMMON FUNCTIONS

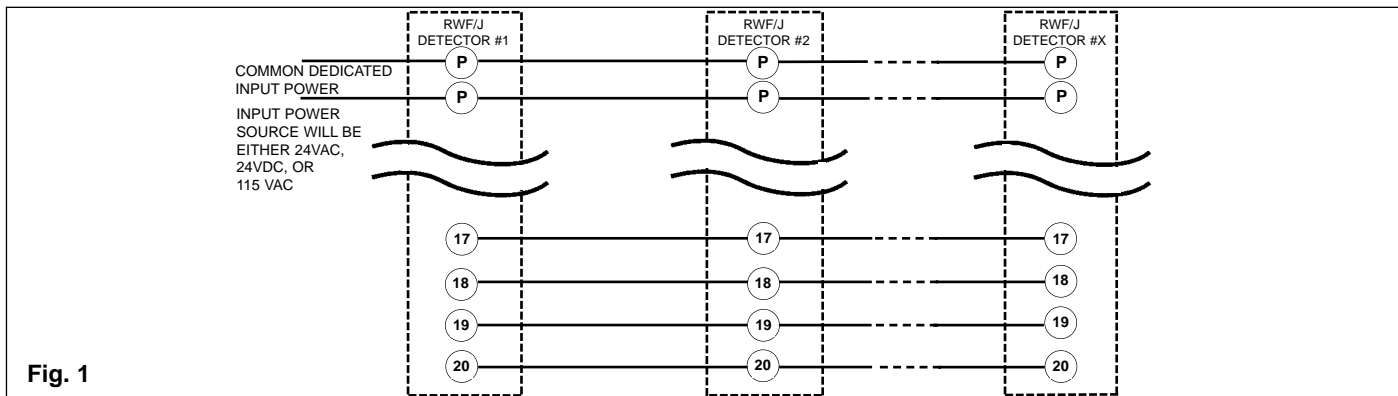
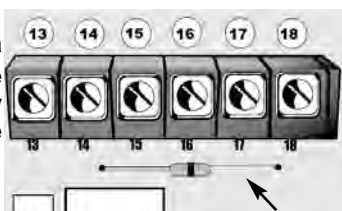

Fig. 1

⚠ IMPORTANT NOTE: The RWJ, with jumper installed, will not allow for the monitoring of trouble contacts 14-15 by a fire control panel, as a 24VDC voltage will be present on these terminals. By removing the jumper, the RWJ Duct unit will operate as a RWF Duct unit; i.e. there will be no external voltage on terminals 14-15.

⚠ NOTE: When wiring to a Fire Alarm Control Panel, the jumper option located directly below terminals 14 and 18 on the circuit board must be cut.



Above: RWJ jumper option (zero ohm resistor)

Installations requiring common functions must be wired as shown in fig. 1 (above). Common functions include one or all of the following:

- Remote common alarm indication
- Remote common test/reset
- Common shutdown
- Common alarm audible/visual indication.

Common fault indication (when green pilot LED is extinguished or yellow trouble LED is illuminated) cannot be achieved on the RWJ/J Duct Units. Individual remote pilot, or fault trouble LED's must be installed to monitor detector head or power source removal for each unit. In a common scenario, in the event of an alarm, the detector head and duct unit alarm (red) LED's will be illuminated on the unit starting the alarm. All remaining duct unit alarm LED's will not be illuminated.

All remote alarm LED's fitted to the duct units will be illuminated when any of the units go into alarm. Only the duct unit in alarm will permit resetting of the system from the built in test/reset switch on that particular duct unit. A common remote reset switch will reset all common wired detector units.

⚠ NOTE: A maximum of 30 units may be interconnected under a common shutdown configuration. When connecting individual remote accessories, up to 15 units may be configured in this manner, except when connecting a SHP24-1575 Horn/Strobe. In this case, no more than 4 units may be configured.

REMOTE ACCESSORY WIRING

Remote accessory terminals 16 to 20 are not supervised and the output voltage (24VDC) will be present when the duct detector is in the appropriate condition monitored.

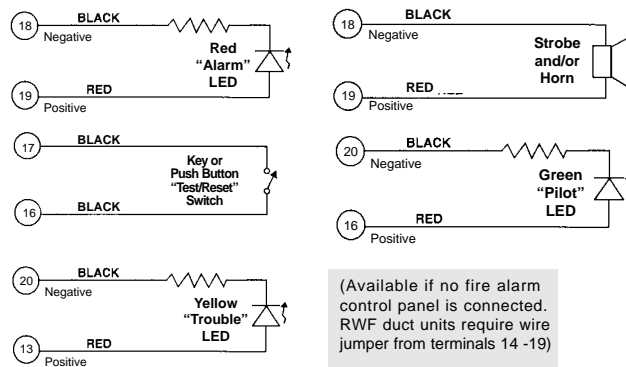

FIRE ALARM CONTROL PANEL WIRING

SAMPLE CONTROL PANEL WIRING - STYLE "D" / CLASS "A" IDC (Supervised - A fault condition will not inhibit an alarm response)

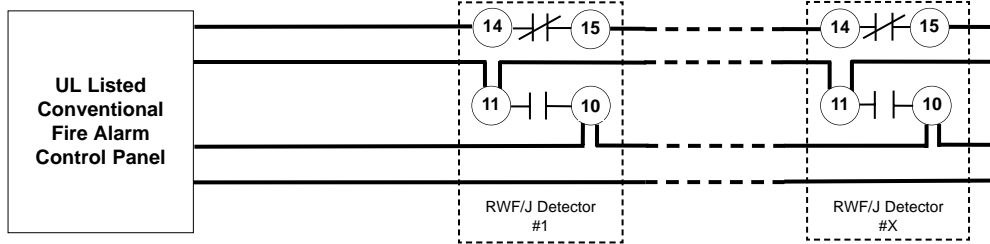

Fig. 2

SAMPLE CONTROL PANEL WIRING - STYLE "B" / CLASS "B" IDC (Supervised - A fault condition will not inhibit an alarm response)

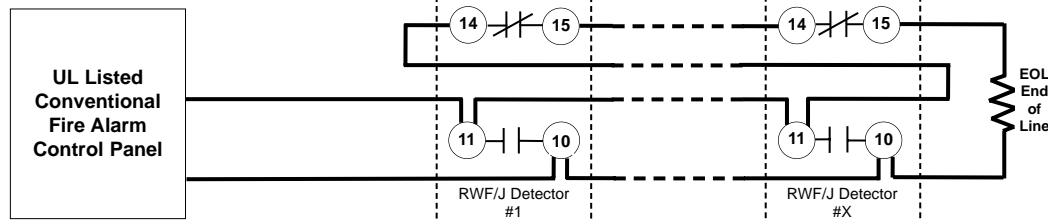

Fig. 3

TESTING PROCEDURES

OPERATIONAL TESTING

To determine the correct operation of the RWF/J-Series duct smoke detector, ensure input power is connected and the green pilot LED is illuminated.

The LED on the detector head of both the Ionization and Photoelectric models (55000-225APO and 55000-328APO) will flash while the unit is in standby mode. The LED on the detector head of both the Ionization and Photoelectric models (55000-250APO and 55000-350APO) will not flash while the unit is in the standby mode. The LED on all the above detector heads will be permanently illuminated when smoke is detected and the head is in alarm.

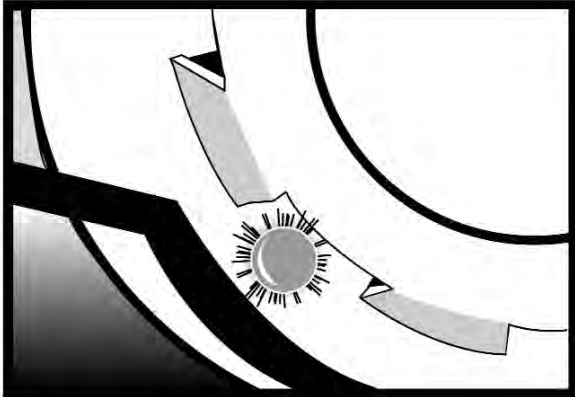

Above: The LED will be permanently illuminated when the unit is in alarm.

With the air handling unit shut down (not connected), and the clear cover removed, press and hold the test/reset button on the RWF/J duct unit. The red alarm LED on the circuit board will be illuminated and the alarm relay outputs will change state. Using a multimeter set to OHMS (or continuity buzzer function on the meter) place the meter probes on the following terminals, and ensure the contacts are closed (continuity) (7-8) and (10-11). When releasing the test/reset button these contacts will open.

The trouble contacts 13, 14, 15 on the RWF/J duct units will not change state in the event of a fire alarm, operational, or functional testing. The trouble contacts can be tested by rotating the Apollo detector head counter-clockwise and removing the detector head. This action will extinguish the green pilot LED and cause the trouble contacts to change state, (13-14) will be closed (continuity) and (14-15) will be open circuit. Replacing the detector head and rotating it clockwise until it locks, will cause the green pilot LED to be illuminated and the unit will be operational, terminals (13-14) will be an open circuit and (14-15) will be closed (continuity).

FUNCTIONAL TESTING

Once operational testing is concluded the unit requires functional testing to determine the correct operation of the detector head.

With the clear cover removed, air handling unit shut down, and using the aerosol test smoke Apollo test gas part # TG-1000, spray the test gas directly at the detector head from a distance of 12 inches for 2 seconds.

⚠ CAUTION: SPRAYING FROM A DISTANCE CLOSER THAN 12 INCHES MAY CAUSE DETECTOR CONTAMINATION.

After 15 to 20 seconds the detector head will go into alarm, illuminating the detector head LED and causing the duct unit functions to operate, alarm relays will change state, and the alarm related remote accessories, if attached, will function.

If no test gas is available to conduct functional testing, light a piece of clothesline (rope) and blow the flame out, hold the smoldering rope 3" from the detector head and lightly blow across the smoldering area towards the detector head, the alarm indicator should illuminate within one minute.

Should additional testing also be required for simulated fire conditions, smoke bombs placed in the duct may not be suited for the particular detector head (photoelectric or ionization) selected and installed. Consult the smoke bomb data for proper use and compatibility with detector type.

S65A Ionization detector head 55000-225APO and S60A Ionization detector head 55000-250APO utilize a radioactive source as its means of detection and will detect smoke particles of between .1 and 1 micron in size.

S65A Photoelectric detector head 55000-328APO and S60A Photoelectric detector head 55000-350APO operate on the principle of light scatter and will detect smoke particles of between 1 and 10 microns in size.

When purchasing smoke bombs for additional required functional testing, ensure smoke particle sizes comply with the criteria as described above.

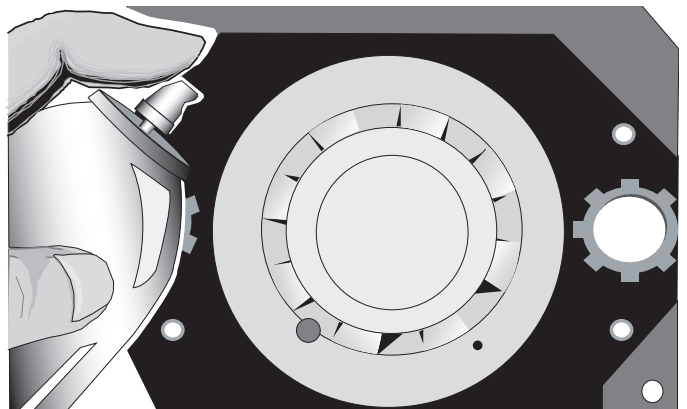

Above: For factory recommended functional testing, spray the proper test gas directly at the detector head from a distance of 12 inches for 2 seconds.

MAINTENANCE

Each installation location must be assessed on its own merits. If the protected area is of a very dirty nature then the RWF/J Duct unit(s) will have to be checked and cleaned on a quarterly basis or when cleaning is required.

As a guideline the Apollo detector head should be cleaned every six months or as required. The best methods of cleaning are to vacuum the detector head thoroughly or to blow the detector head out using clean, dry compressed air.

Do not use chemicals or non-conforming air to clean the detector head housing as this could contaminate the detector head and damage the casing.

Sensing tubes must be inspected and cleaned in accordance with the schedule as determined above, to allow the free flow of air through both inlet and exhaust tubes.

Consult your local code and AHJ requirements for required maintenance schedules.



Air Products and Controls Inc.
1749 E. Highwood Pontiac, MI 48340
Telephone: (888) 332-2241
Fax: (248) 332-8807
E-mail: tech@ap-c.com
www.ap-c.com

AVAILABLE ACCESSORIES FOR USE WITH RWF AND RWJ SERIES DUCT SMOKE DETECTORS

REMOTE ACCESSORIES

MS-RA	Remote Alarm
MS-KA/P/R/T	Remote Pilot, Trouble, Key-Operated Test/Reset Switch
MS-RA/P	Remote Alarm, Pilot
MS-F/T	Remote Trouble
MS-RA/R	Remote Alarm, Push-Button Test/Reset Switch
MS-RH/P/A	Remote Alarm, Pilot, Horn
MS-RA/P/R	Remote Alarm, Pilot, Push-Button Test/Reset Switch
MS-RH/KA/P/R	Remote Alarm, Pilot, Horn, Key-Operated Test/Reset Switch
MS-RA/P/T	Remote Pilot, Trouble
MS-RH/KA/P/A/T	Remote Alarm, Trouble, Pilot, Horn, Key-Operated Test/Reset Switch
MS-RA/FT/P	Remote Pilot, Trouble, Push-Button Test/Reset Switch
MS-RH	Remote Alarm Horn
MS-KA/R	Remote Alarm, Key-Operated Test/Switch
MS-KA/P/R	Remote Alarm, Pilot, Key-Operated Test/Reset Switch
MS-RD	Remote Alarm
SHP24-15750	Horn/Strobe, white housing, opaque cover
SHP24-1575R	Horn/Strobe, red housing, clear cover
SHP24-1575W	Horn/Strobe, white housing, clear cover

SMOKE TEST GAS

TG-1000	Solo Aerosol Test Gas
---------	-----------------------

SAMPLING TUBES

STS-1.0	For duct widths of 6" TO 1.0'
STS-2.5	For duct widths of 1.0' TO 2.5'
STS-5.0	For duct widths of 2.5' TO 5.0'
STS-10.0	For duct widths of 5.0' TO 10.0'

POWER SUPPLIES

T-PB 202-1	24VAC, 4.0A (96VA) Class I Power Supply
T-PB 202-0	24VAC, 4.0A (96VA) Class I Power Supply
T-PB 303-1	24VAC, 3.0A (72VA) Class II Power Supply
T-PB 303-0	24VAC, 3.0A (72VA) Class II Power Supply

WEATHERPROOF ENCLOSURES

WP-1	Weatherproof Enclosure
------	------------------------



DUCT SMOKE DETECTORS INSTALLATION INSTRUCTIONS

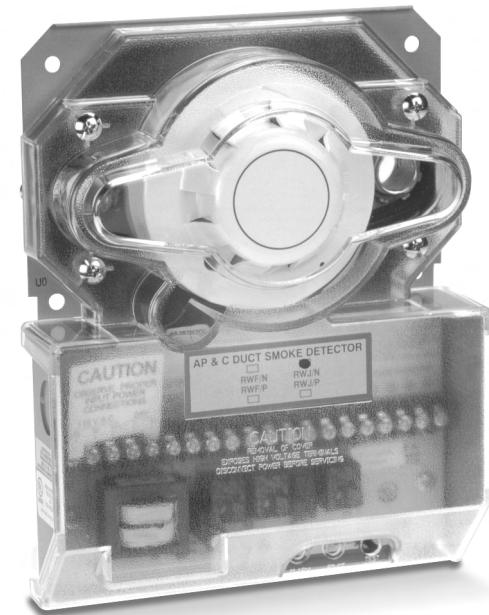

RWF-N or RWJ-N Ionization; 4-WIRE; 24VAC, 24VDC, OR 115VAC
RWF-P or RWJ-P Photoelectric; 4-WIRE; 24VAC, 24VDC, OR 115VAC

NOTICE: The information contained in this document is the most current available at the time of shipment of accompanying product, and is subject to change without notice. Future references should always be made to the most current revision of this document. The information contained in all this document should be considered before installing or using the product. Any example applications shown are subject to the most current enforced local/national codes, standards, approvals, certifications, and/or the authority having jurisdiction. All of these resources, as well as the specific manufacturer of any shown or mentioned related equipment, should be consulted prior to any implementation. For further information or assistance concerning this product, contact Air Products and Controls Inc. Air Products and Controls Inc. reserves the right to change any and all documentation without notice.

© Air Products and Controls Inc. 2004

A COPY OF THESE INSTRUCTIONS SHOULD BE LEFT WITH THE EQUIPMENT UNTIL INSTALLATION BY ALL TRADES IS FULLY COMPLETE. FOLLOWING FINAL INSPECTION, A COPY SHOULD BE LEFT WITH THE OWNER/USER.

CITY OF NEW YORK
DEPARTMENT OF BUILDINGS

Pursuant to Administrative Code Section 27-131, the following equipment or material has been found acceptable for use in accordance with the Report of Materials and Equipment Acceptance (MEA) Division.

Richard C. Visconti, R.A., Acting Commissioner
MEA 73-92-E Vol. XV

Report of Material and Equipment Acceptance Division

Manufacturer - Air Products and Control Inc., 1749 East Highwood, Pontiac, MI 48340

Trade Name(s) - Air Products and Controls Inc.

Product - Smoke Automatic Fire Detectors, Duct Application.

Pertinent Code Section(s) - Reference Standard RS 17.

Prescribed Test(s) - Compliance with U.L. 268A.

Laboratory - Underwriters Laboratories, Inc.

Test Report - File S2829, Project 97NK32301, dated May 4, 1998 and Revised May 7, 1999.

Description - The duct detectors are intended to detect an abnormal amount of smoke density in the return air ducts of air conditioning and ventilating systems. The units operate to shut down blowers to prevent abnormal smoke distribution and a possible panic hazard. The duct detectors consist of a plastic enclosure, relay, electrical components, listed open area detector, and a sampling and exhaust tube.

Models with -N suffix are 4-wire ionization type detectors, models with -P suffix are 4-wire photoelectric type detectors.

The air duct smoke detectors provide early warning of smoke moving through air ducts and intended to prevent the spread of smoke through a protected area. Operating power may be 115VAC, 24VAC or 24VDC. The detectors consists of the following model numbers:

Model No.	Description
RWF-N	Ion: (2) sets of 10.0A Alarm contact & (1) set 10.0A Trouble Contact.
RWF-P	Photo: (2) sets of 10.0A Alarm contact & (1) set 10.0A Trouble Contact.
RWJ-N	Ion: (2) sets of 10.0A Alarm contact.
RWJ-P	Photo: (2) sets of 10.0A Alarm contact.

Pursuant to "Promulgation of the Rules relating to Material and Equipment Application Procedures" dated November 5, 1992. The Bureau of Fire Prevention has no objections letter dated June 28, 1999, F.P. Index # 9906025.

Recommendation - That the above duct smoke detectors be accepted on conditions that all uses, configurations, arrangements and functions, locations and installations comply with the New York City Building Code, specifically Subchapter 17 and with Reference Standards RS13 and RS 17-3, NFPA 72, UL 268A Standard, UL Listing, manufacturer's instructions, Fire Department Rules and the Electrical Code of the City of New York.

All shipments and deliveries of such equipment shall be provided with a metal tag, suitably placed, certifying that the equipment shipped or delivered is equivalent to those tested and accepted for use, as provided for in Section 27-131 of the Building Code.

Final Acceptance July 14, 1999

Examined By Mark J. Kelly

CALIFORNIA DEPARTMENT OF FORESTRY & FIRE PROTECTION
OFFICE OF THE STATE FIRE MARSHAL
FIRE ENGINEERING - BUILDING MATERIALS LISTING PROGRAM

LISTING SERVICE

LISTING No. 3240-1004:105 Page 1 of 1

CATEGORY: Duct Smoke Detector Housing/Base

LISTEE: Air Products and Controls Inc., 1749 East Highwood, Pontiac MI 48340
Contact: *Richard Steele (248) 332-3900 *FAX (248) 332-8807

DESIGN: Models RWH-N, RWH-P, RWL-N, RWL-P, RWX-N, RWX-P, RWJ-N, RWJ-P, RWF-N, RWF-P and SL-2000-N and SL-2000-P duct smoke detectors. All units are four-wire duct detectors. Suffix -N indicates the unit employs an ionization smoke detector head. Suffix -P indicates the unit employs a photoelectric smoke detector head.

Refer to listee's data sheet for additional detailed product description and operational considerations.

RATING: 24 VAC, 24 VDC, 115 VAC or 230 VAC

INSTALLATION: In accordance with listee's printed installation instructions, applicable codes & ordinances and in a manner acceptable to the authority having jurisdiction.

MARKING: Listee's name, model number, electrical rating and UL label.

APPROVAL: Listed as duct detectors for use with separately listed compatible fire alarm control units when installed in HVAC systems with air velocity between 500 and 4000 ft./min.

*Rev. 05-28-2004



This listing is based upon technical data submitted by the applicant. CSFM Fire Engineering staff has reviewed the test results and/or other data but does not make an independent verification of any claims. This listing is not an endorsement or recommendation of the item listed. This listing should not be used to verify correct operational requirements or installation criteria. Refer to listee's data sheet, installation instructions and/or other suitable information sources.

Date Issued: **JUNE 22, 2004**

*Listing Expires **June 30, 2005***

Authorized By: **DIANE K. AREND, Senior Deputy
Program Manager**