

Mark 9020 Series

Sanitary Ball Valves

CRN Registration Number Available

New: Optional Integral bottom condensate drain.
See pages 9 & 10

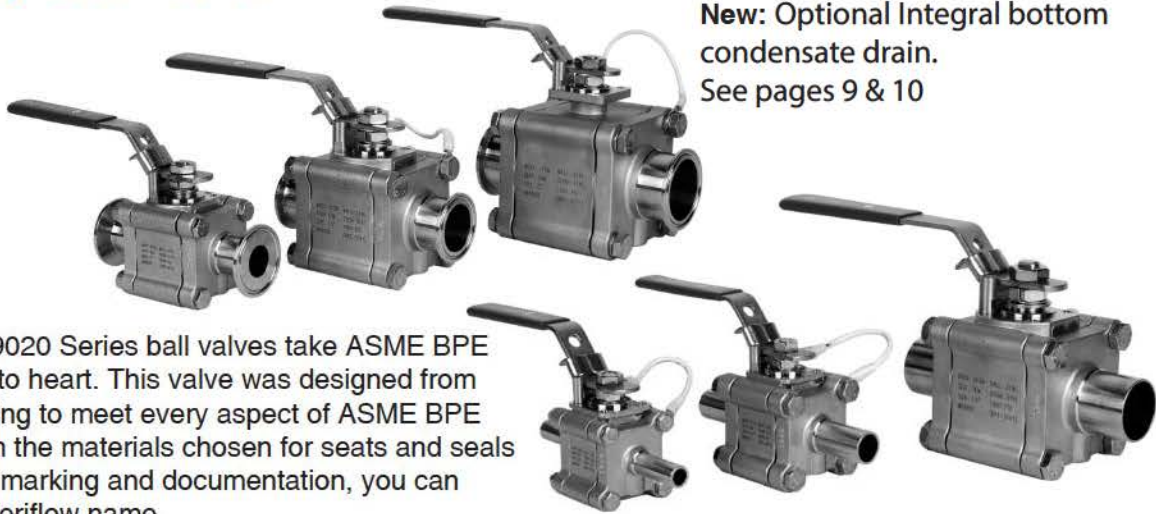

The Mark 9020 Series ball valves take ASME BPE guidelines to heart. This valve was designed from the beginning to meet every aspect of ASME BPE 2014. From the materials chosen for seats and seals to the final marking and documentation, you can trust the Steriflow name.

FEATURES

- Traceable Industry grade high density 316L body, ball, stem and end caps with 1% ferrite standard
- Certified TFM 1600 body seal, seat, thrust washer, and packing material meet:
 - FDA 21 CFR 177
 - Final form materials also certified to meet USP <88> Class VI (in-vivo), and USP <87> (in-vitro) testing requirements
- Internal waterway surface finish is SF1 (20 Ra μin (.5 Ra μm) Mechanical Polish), SF4 (15 Ra μin (.4 Ra μm) mechanical/electropolish optional)
- Ball porting has identical ID as inlet/outlet tubing to prevent holdup
- Pressure ratings to 1000 psig @ 100°F
- Anti-blowout stem design
- Tongue & groove body seal to insure gasket containment and precise alignment regardless of vibration
- Tri-clamp ends, extended tube weld ends, or both available on all sizes
- Available as manual or actuated (pneumatic/electric) valve
- ISO 5211 actuator mounting flange direct on body, or on stem extensions
- Optional cavity filler seats available for non-BPE applications
- Optional condensate drain and purge ports
- Stem grounding standard

DOCUMENTATION

The following documentation is shipped with each order:

- Steriflow Unicert
 - Certificate of Material compliance with Traceable MTR's
 - Certificate of Compliance to FDA and USP <88> Class VI and USP <87>
 - Certificate of Compliance to Surface Finish
- Final Test Reports and Certificate of Origin available upon request at time of order

APPLICATIONS

- Biopharmaceutical, Pharmaceutical Clean Steam, Condensate, or CIP
- Biopharmaceutical, Pharmaceutical Clean Air and Gas
- Food and Beverage
- Fine and Specialty chemicals
- Any viscous media or other application where inline valve cleaning or remove-for-cleaning access is desired



Steriflow by Jordan Valve

3170 Wason Road • Cincinnati, OH 45209
513.533.5600 • 800.543.7311 • 513.871.0105 (f)
steriflow@richardsind.com • www.steriflowvalve.com

SAMPLE SPECIFICATIONS

Mark 9020 Series (1/2" – 4") Investment Cast two-way, three piece sanitary ball valve, shall be designed, manufactured, marked, and documented per ASME BPE-2014.

Body seal, seat, thrust washer, and packing shall be manufactured from FDA 21 CFR 177 acceptable TFM 1600, which has been tested in final form to meet the requirements of USP Chapter 88 Class VI (in-vivo) and USP Chapter 87 (in-vitro).

Body, ball, and end caps shall be manufactured from ASTM A351 Gr. CF3M 316L with ferrite controlled to 1%.

Internal waterway surface finish shall be SF1, 20Ra mechanical polish, or optional to SF4, 15 Ra mechanical polish with electropolish.

Mounting flange on body and stem extensions shall be designed to ISO 5211 to facilitate actuator attachment.

Valves shall not require disassembly for welding and shall be repairable inline.

Maximum working pressure shall be 1000 psi to vacuum at 100°F for 1/2" through 2" design, 720 psi to vacuum for 2-1/2" through 4" sizes.

Weld end fittings or ferrules to match sanitary tubing connections. Body bolts and nuts to be 304 or better strain-hardened with minimum tensile strength of 100,000 psi.

Stem packing shall be live loaded TFM® V-rings to compensate for pressure and thermal cycles and for wear, to insure a positive seal against process leaks.

Steriflow model series Mark 9020 size, material, seat/stem extension, ends, manual/automated, actuator accessories, fail position.

FEATURES & BENEFITS – 1/2" – 1-1/2"

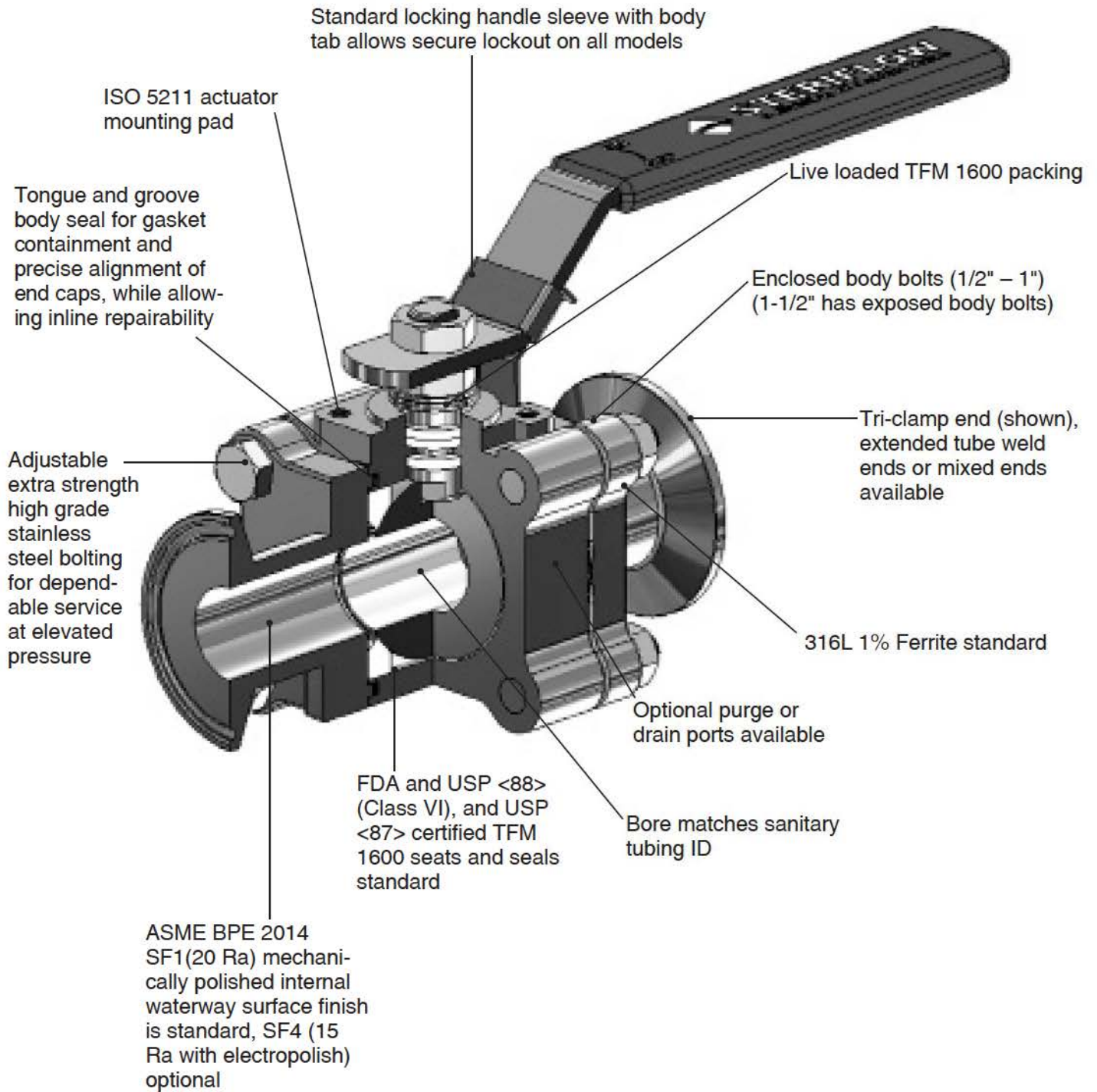

MARK 9020 SERIES SANITARY BALL VALVES

DIMENSIONS (1/2" THROUGH 1-1/2")

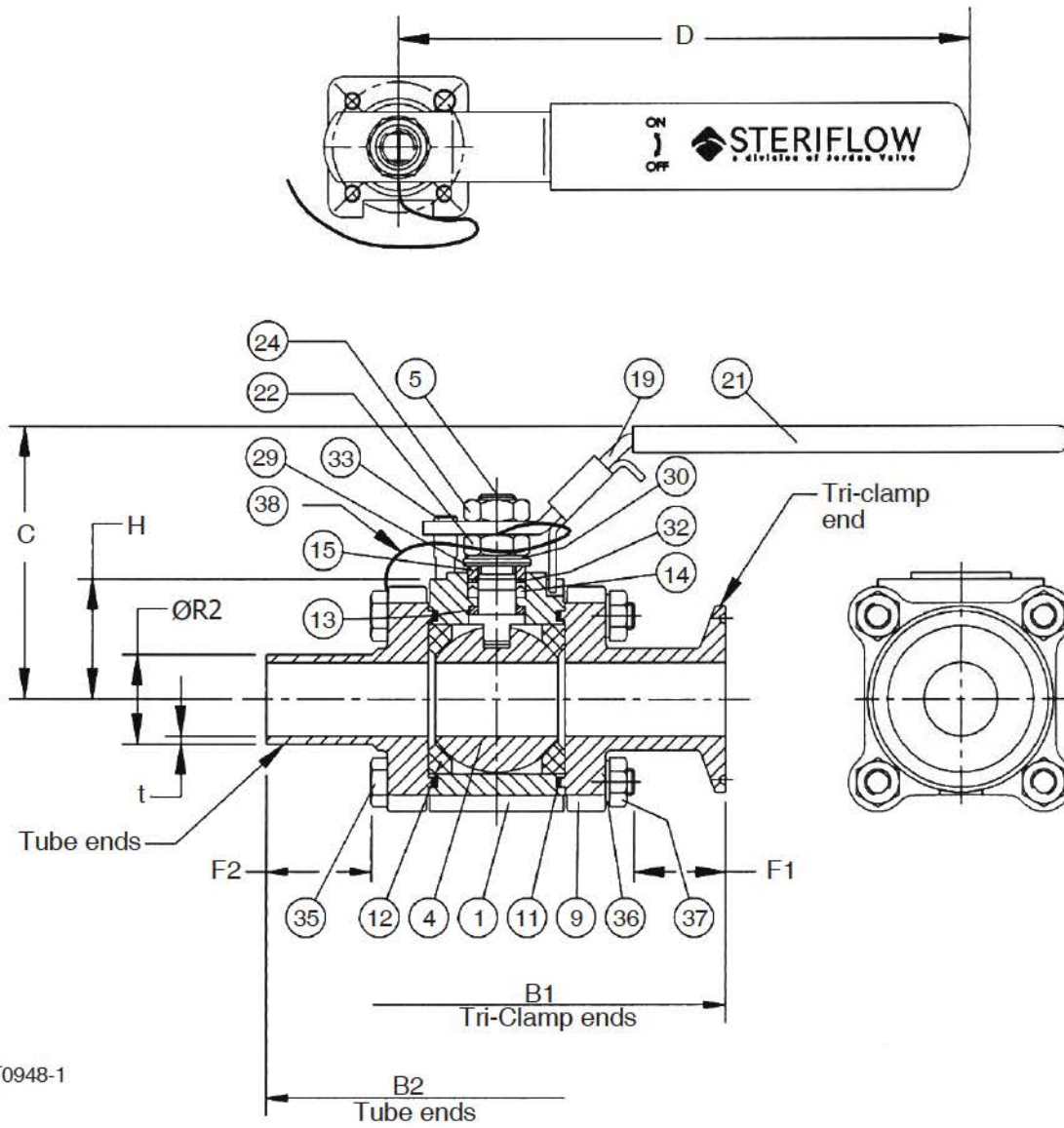

Inches

Size	Port	Tri-Clamp Ends			Tube Ends					D	C	H
		B1	F1	Wt. Lb	B2	F2	R2	t	Wt. Lb			
1/2"	0.37	3.58	0.51	2.0	4.94	1.19	0.50	0.065	1.9	5.23	3.73	1.22
3/4"	0.63	4.25	0.73	3.1	5.29	1.25	0.75	0.065	3.0	5.23	2.91	1.38
1"	0.87	5.15	1.00	4.6	5.74	1.25	1.00	0.065	4.4	6.76	3.22	1.50
1-1/2"	1.37	5.91	0.91	9.0	6.51	0.96	1.50	0.065	8.9	8.04	3.84	1.92

SPECIFICATIONS (1/2" THROUGH 1-1/2")

Item	Part Name	Quantity	Material
1	Body	1	ASTM A351 Gr. CF3M, 316L
4	Ball	1	ASTM A351 Gr. CF3M
5	Stem	1	316L SS Bar
9	End Cap	2	ASTM A351 Gr. CF3M
11	Body Seal	2	TFM1600
12	Seat	2	TFM1600
13	Thrust Washer, Stem	1	TFM1600
14	Packing, Stem	1 Set	TFM1600
15	Gland, Packing	1	AISI 304 SS
19	Handle	1	AISI 304 SS
21	Cover, Handle	1	Vinyl
22	Nut, Gland	1	AISI 304 SS
24	Nut, Handle	1	AISI 304 S
29	Belleville Washer	2	AISI 301 SS
30	Lock Tab Washer	1	AISI 304 SS
32	Thrust Washer, Packing	1	TFM1600
33	Stop Pin, Handle	1	AISI 304 SS
35	Bolt, Body	4	AISI 304 SS
36	Lock Washer, Body Bolt	4	AISI 304 SS
37	Nut, Body Bolt	4	AISI 304 SS
38	Grounding Cable	1	Braided Copper/Vinyl

END ARRANGEMENTS & ORDERING CODES FOR UNEQUAL ENDS

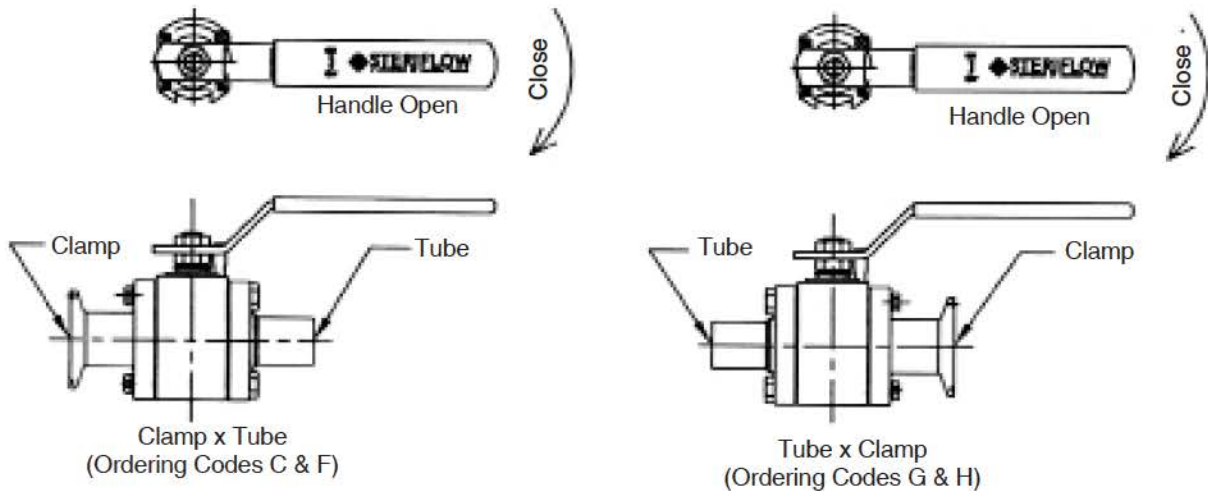

MARK 9020 SERIES SANITARY BALL VALVES

DIMENSIONS (2" THROUGH 4")

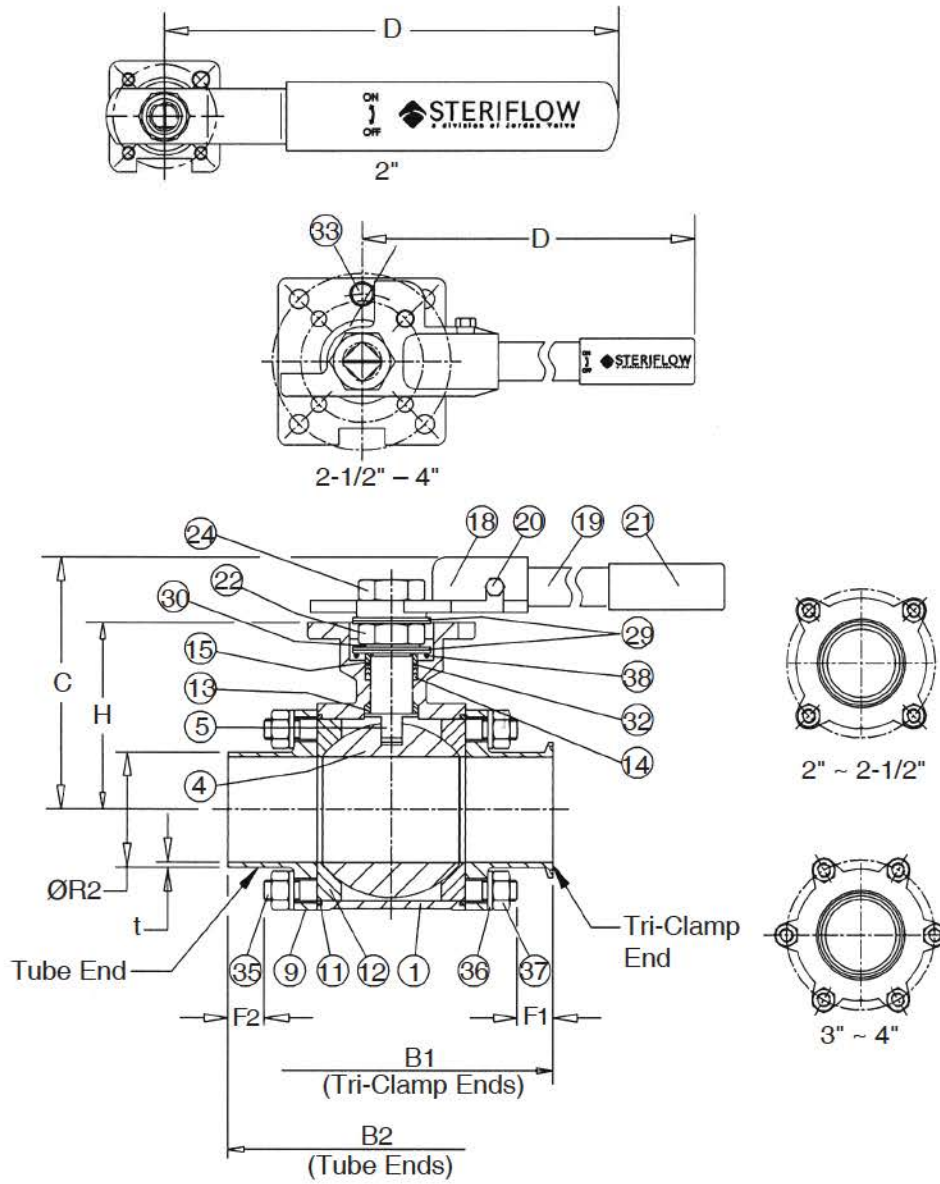

ART0949-1

Inches

Size	Port	Tri-Clamp Ends			Tube Ends					D	C	H
		B1	F1	Wt. Lb	B2	F2	R2	t	Wt. Lb			
2"	1.87	6.53	0.75	10.2	6.87	1.04	2.00	0.065	10.0	8.0	4.9	3.25
2-1/2"	2.37	8.00	0.72	19.2	8.75	1.30	2.50	0.065	19.7	14.3	5.8	4.25
3"	2.87	9.19	1.09	28.4	9.25	1.06	3.00	0.065	27.0	14.3	6.0	4.56
4"	3.84	10.23	1.16	50.0	10.21	1.15	4.00	0.083	48.0	15.7	7.7	6.10

MARK 9020 SERIES SANITARY BALL VALVES

SPECIFICATIONS (2" THROUGH 4")

Item	Part Name	Quantity	Material
1	Body	1	ASTM A351 Gr. CF3M
4	Ball	1	ASTM A351 Gr. CF3M
5	Stem	1	316L SS Bar
9	End Cap	2	ASTM A351 Gr. CF3M
11	Body Seal	2	TFM1600
12	Seat	2	TFM1600
13	Thrust Washer, Stem	1	TFM1600
14	Packing, Stem	1 Set	TFM1600
15	Gland, Packing	1	AISI 304 SS
18	Adaptor, Handle	1	AISI 304 SS
19	Handle	1	AISI 304 SS
20	Bolt, Handle	1	AISI 304 SS
21	Cover, Handle	1	Vinyl
22	Nut, Gland	1	AISI 304 SS
24	Nut, Handle	1	AISI 304 SS
29	Belleville Washer	2	AISI 304 SS
30	Lock Tab Washer	1	AISI 301 SS
32	Thrust Washer, Packing	1	TFM 1600
33	Stop Pin, Handle	1	AISI 304 SS
35	Stud, Body	4 ~ 6	AISI 304 SS
36	Lock Washer, Body Bolt	8 ~ 12	AISI 304 SS
37	Nut, Body Bolt	8 ~ 12	AISI 304 SS
38	Grounding Spring	1	AISI 304 SS
39	Locking Sleeve	1	AISI 304 SS

FEATURES & BENEFITS – 2" – 4"

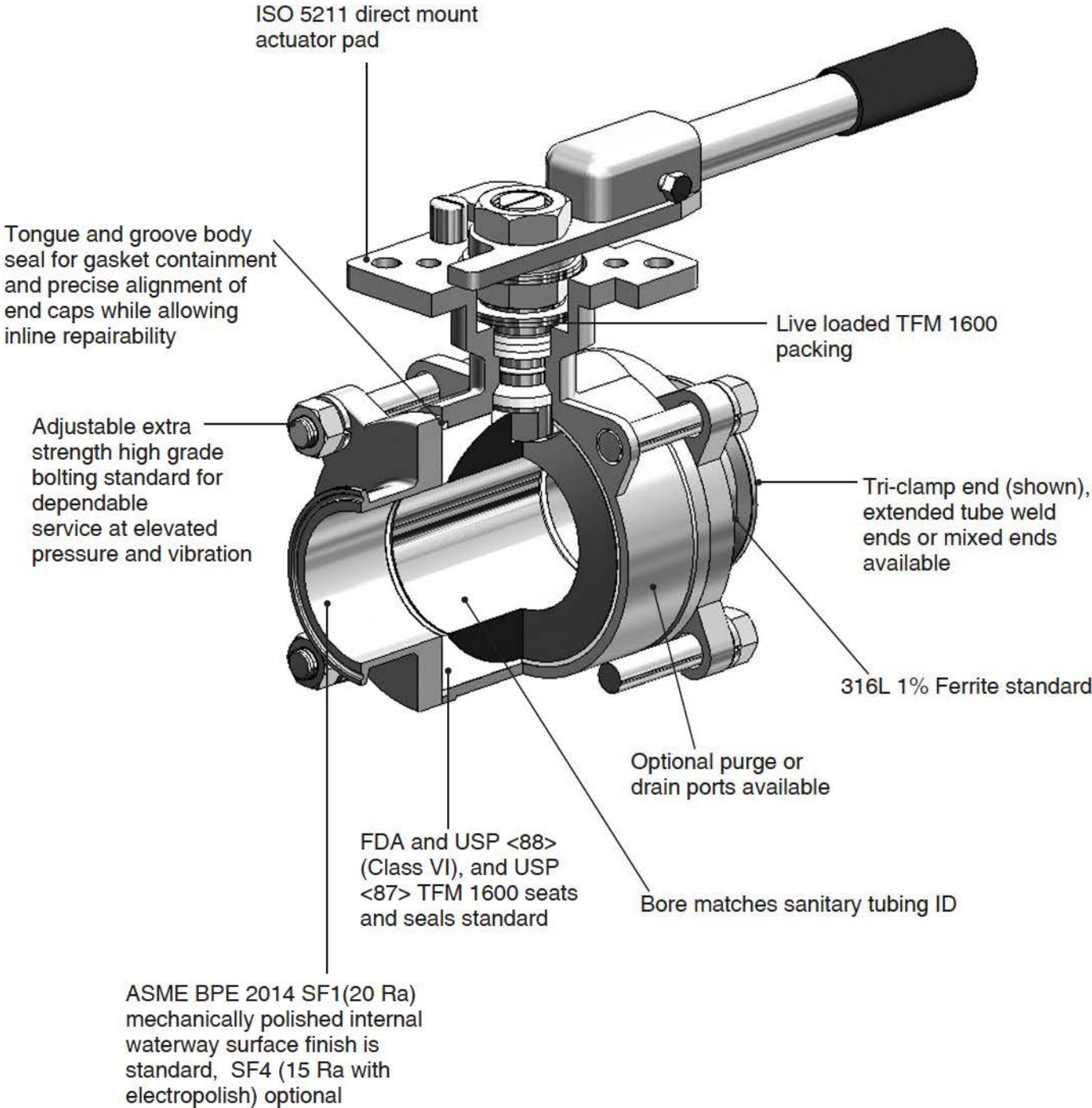

ART0958

FEATURES & BENEFITS – CONDENSATE DRAIN OPTION

Unique condensate drain option directs upstream clean steam condensate, or trapped liquids in the body cavity, to drain.

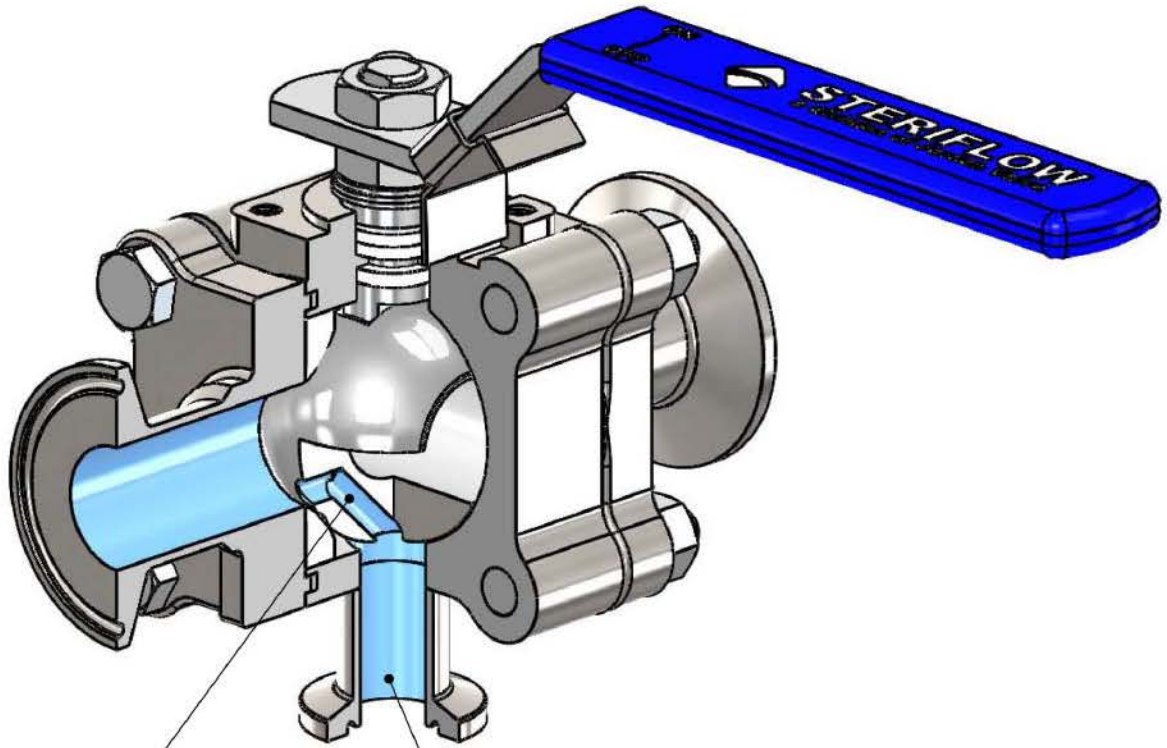

Tri-clamp™ condensate drain removes condensate or liquids from the body cavity surrounding the ball. It also insures complete sterilization of the body cavity.

When the valve is in the closed position, this port directs clean steam condensate from the closed inlet side of the ball to drain, preventing liquid backup. (Also see next page)

ART 1315

CONDENSATE DRAIN OPTION (BODY ORDER CODES DL AND DF)

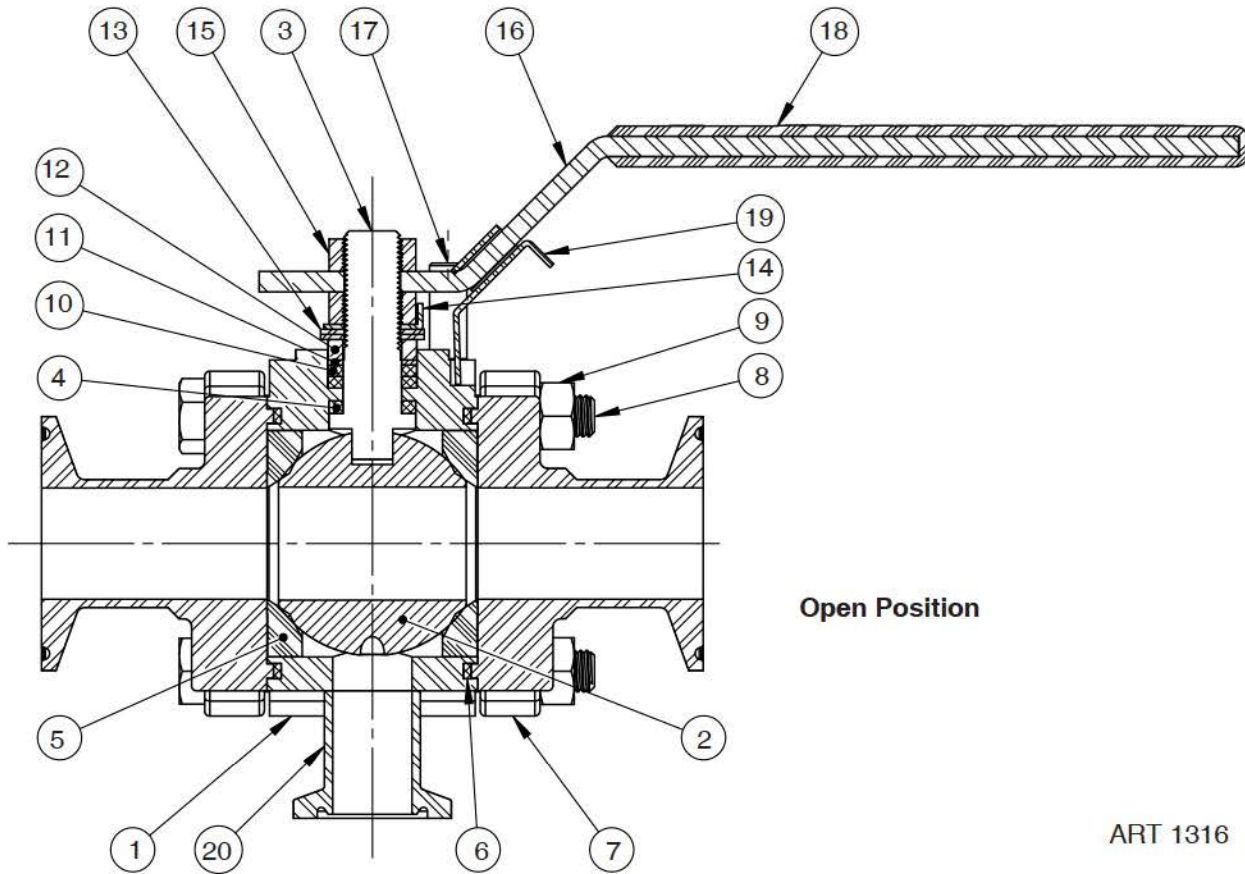

ART 1316

Item No.	Description	Quantity
1	Body	1
2	Ball	1
3	Stem	1
4	Thrust Washer	1
5	Seat	2
6	Body Seal	2
7	Cap	2
8	Body Bolt	4
9	Bolt Nut	4
10	Stem Packing	2
11	Follower Washer	1
12	Gland Bush	1
13	Bellville Washer	2
14	Tab Washer	1
15	Stem Nut	2
16	Handle	1
17	Pin	1
18	Handle Cover	1
19	Lock	1
20	Nozzle, Drain	1

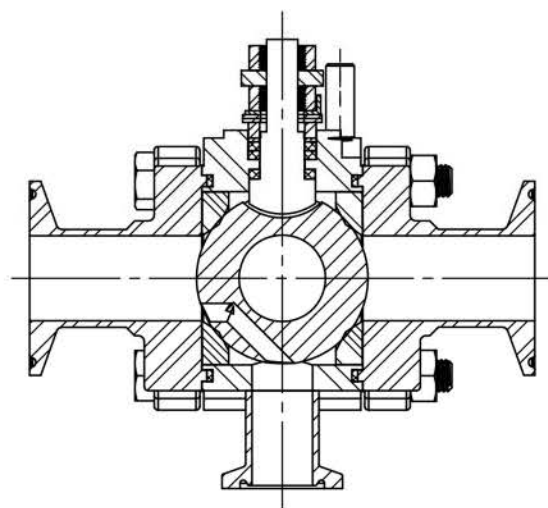

Closed/Vented Position

ACTUATOR MOUNTING DIMENSIONS

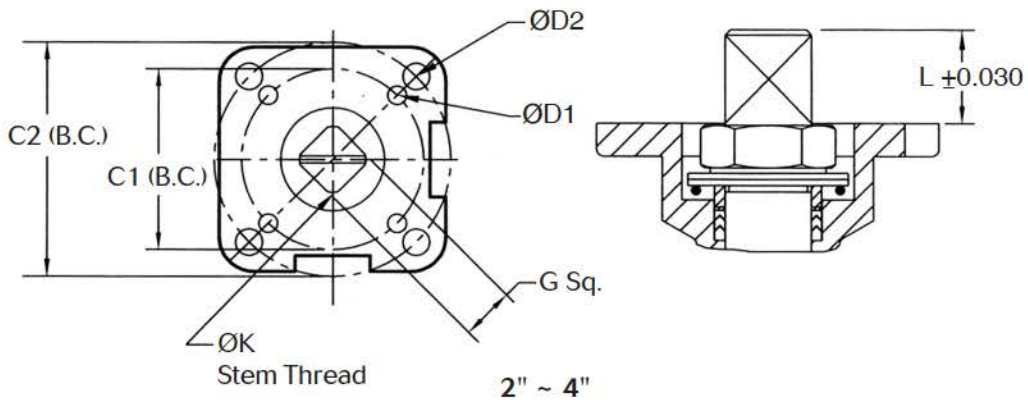
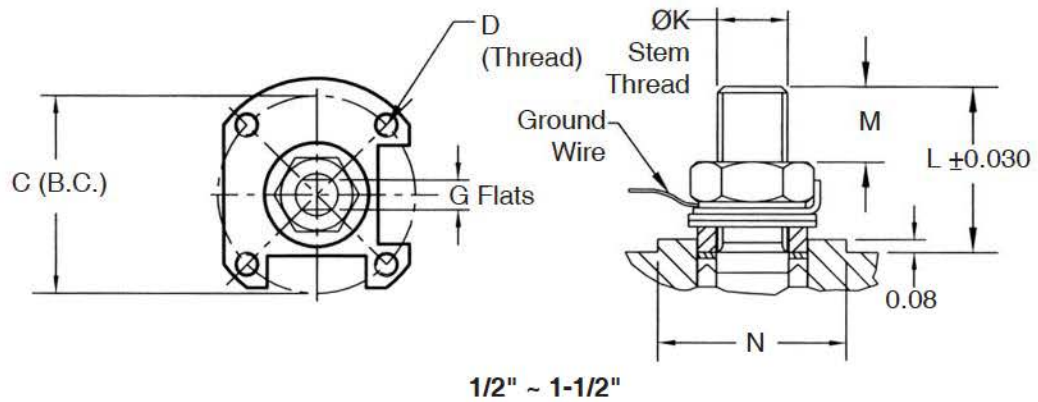

ART0950

Inches

Size NPS	ISO Pattern	C1 (B.C.)	D1	ISO Pattern	C2 (B.C.)	D2	G Flats or Sq.	K Stem Thd.	L	M	N
1/2"	F03	1.42	M5	—	—	—	0.258 / 0.254	0.38-24	0.67	0.30	0.98
3/4"	F03	1.42	M5	—	—	—	0.258 / 0.254	0.38-24	0.73	0.34	0.98
1"	F04	1.65	M5	—	—	—	0.317 / 0.313	0.44-20	1.00	0.40	1.18
1-1/2"	F05	1.97	M6	—	—	—	0.384 / 0.380	M14x1.4	1.26	0.58	1.38
2"	F05	1.97	0.276	F07	2.76	0.354	0.549 / 0.545	0.69-10	0.76	—	—
2-1/2"	F07	2.76	0.354	F10	4.02	0.433	0.671 / 0.677	0.88-14	1.01	—	—
3"	F07	2.76	0.354	F10	4.02	0.433	0.671 / 0.677	0.88-14	1.01	—	—
4"	—	—	—	F12	4.92	0.512	0.868 / 0.864	1.12-12	1.84	—	—

STEM EXTENSION DIMENSIONS

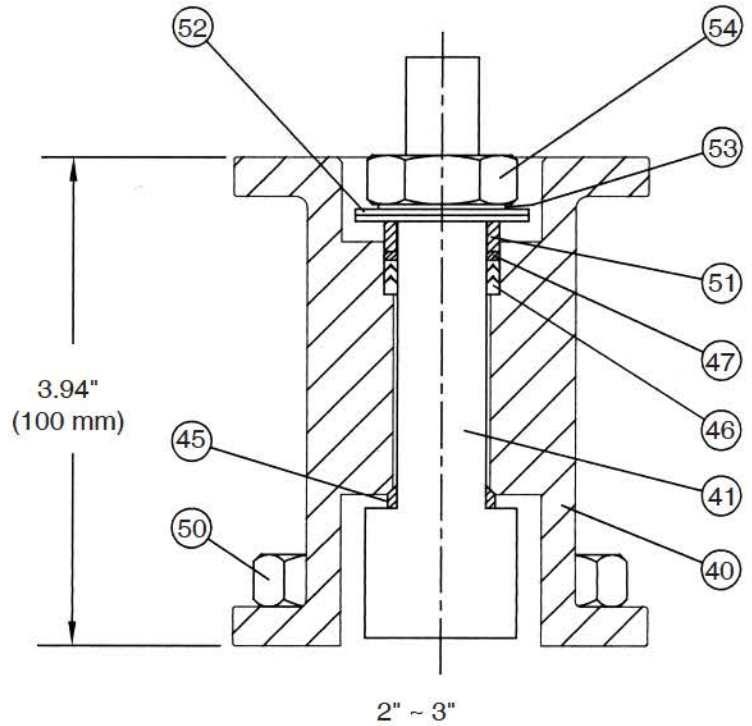
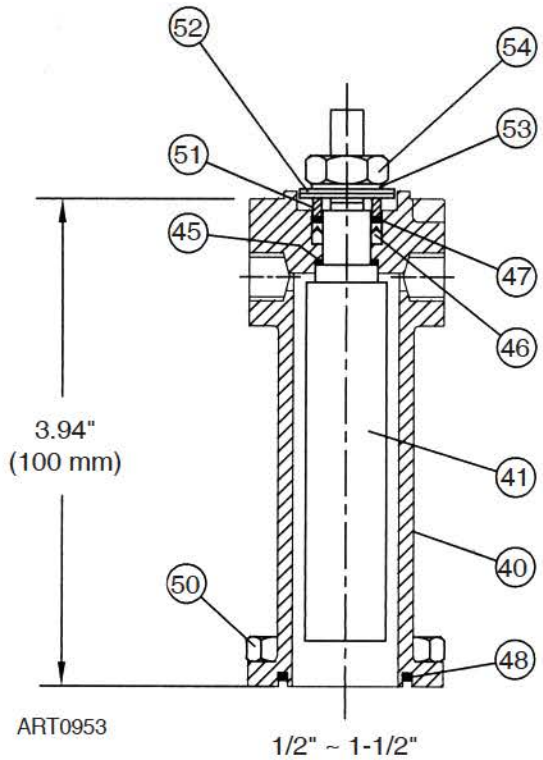

Valve	Ext. Stem P/N
0.5"-9020, DN15-9020D, S	26-92500
0.75"-9020, DN20-9020D, S	26-92501
1"-9020, DN25-9020D, S	26-92502
1.5"-9020, DN40-9020D, S	26-92503

Valve	Ext. Stem P/N
2"-9020, DN50-9020D, S	26-92508
2.5"-9020, DN65-9020D, S	26-92505
3"-9020, DN80-9020D, S	26-92505
4"-9020, DN100-9020D, S	Not Available

Notes:

1. Handle length and actuator mounting dimensions same as top of valve.
2. Add stem extension height "D" above to valve heights for heights of valve with stem extension.

Item	Part Name	Quantity	Material
40	Bonnet	1	ASTM A351 Gr. CF3M
41	Stem, Extension	1	AISI 316L SS
45	Thrust Washer, Ext. Stem	1	AISI 316L SS
46	Packing, Ext. Stem	1 Set	TFM 1600
47	Thrust Washer, Ext. Stem Packing	1	TFM 1600
48	Seal, Bonnet (1/2" ~ 1-1/2")	1	PTFE
50	Bolt, Bonnet	4	AISI 304 SS
51	Gland, Ext. Stem Packing	1	TFM 1600
52	Belleville Washer, Ext. Stem	2	TFM 1600
53	Tab Lock Washer, Ext. Stem	1	AISI 304 SS
54	Nut, Ext. Stem Packing	1	AISI 304 SS
55	Grounding Cable 1/2" - 1-1/2" only (Not Shown)	1	Braided Copper/Vinyl

TRI CLAMP PRESSURE - TEMPERATURE RATINGS

Temp °F	Pressure Rating, psi 13MHP Tri-Clamp (2 bolt)			Pressure Rating, psi A13MHM Tri-Clamp (2-Segment Hinged, Wing Nut)				
	1/2"~2"	2-1/2"~3"	4"	1/2"~1-1/2"	2"	2-1/2"	3"	4"
-20	1000	720	720	500	450	400	350	300
0	1000	720	720	500	450	400	350	300
75	1000	720	720	500	450	400	350	300
250	1000	720	600	300	250	200	175	150

- Tri-Clamp gasket material maximum temperatures: Buna-N, PTFE – 200°F; EPDM – 300°F; Viton — 400°F; Silicon — 450°F
- Pressure ratings based on tri-clamp and maximum pressure rating for product.

TUBE PRESSURE - TEMPERATURE RATINGS

Temp °F	Pressure Rating, 2" ~ 4" Tube End, psi							
	1/2"	3/4"	1"	1-1/2"	2"	2-1/2"	3"	4"
-20 to +300	>1000	>1000	1000	1000	720	695	525	505
350	>1000	>1000	1000	1000	720	610	510	485
400	>1000	>1000	1000	995	720	590	480	470
450	>1000	>1000	1000	960	715	570	470	450

Tube ratings based on ASME B31.3 – 2002 for 316L tubing and on maximum pressure rating for the valve

TECHNICAL INFORMATION

Size NPS	Operating Torque*		Flow Coefficient	
	in-lb	N.m	Cv	Kv
1/2"	39	4,4	8	6,9
3/4"	95	10,7	30	26
1"	148	16,7	65	56
1-1/2"	338	38	190	163
2"	651	74	435	374
2-1/2"	797	90	720	619
3"	974	110	1120	963
4"	1328	150	2100	1806

* TFM 1600 seats, maximum differential pressure

PRESSURE - TEMPERATURE CHART

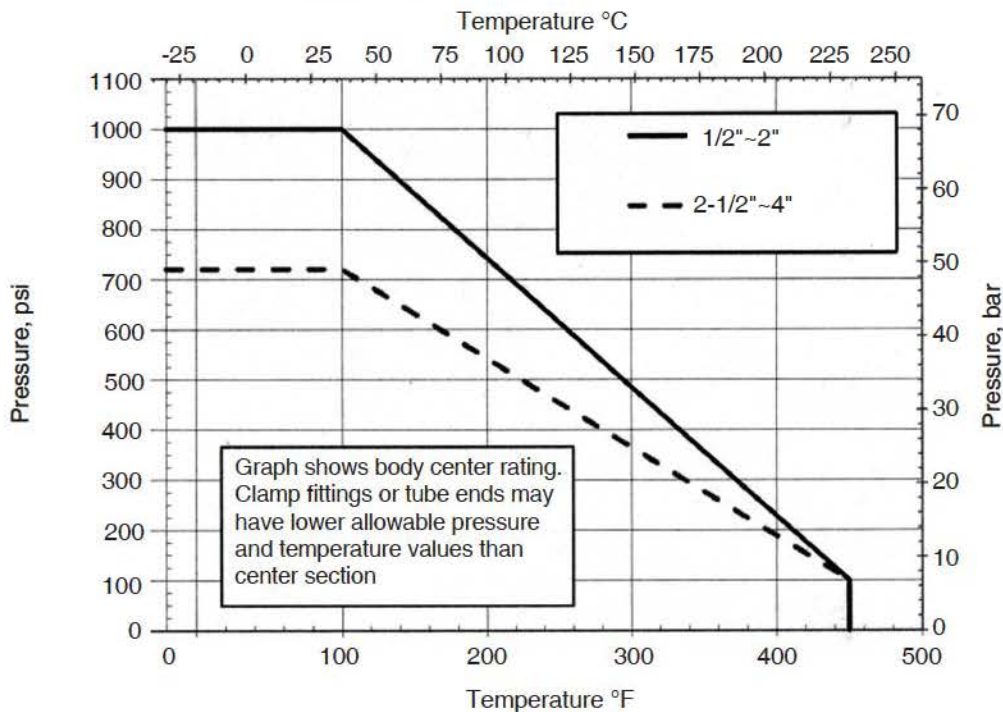

ORDERING SCHEMATIC

Model	Size	Body Mat'l	1	2	3	4	5	6	7	8	9	10	11	12	13	14	15
			/														

Model Number	
9020	3-Pc BPE Sanitary Ball Valve

Size	
050	1/2"
075	3/4"
100	1"
150	1-1/2"
200	2"
250	2-1/2"
300	3"
400	4"

Body Material/Drain Option	
LF	CF3M 1% Ferrite
DF	CF3M 1% Ferrite w/ 1/2" Tri-clamp body condensate drain

Seat/Stem Extension	
T	TFM1600 Enhanced Teflon (Std.)
C	TFM1600 Cavity Filler Enhanced Teflon
E	TFM1600 with Enclosed Stem Extension*
S	TFM1600 Cavity Filler with Stem Extension*

* Not available on 4" models

Ends	
A	Tri-Clamp / SF1 Int. Fin. (Std.)
B	Extended Tube End / SF1 Int. Fin. (Std.)
C**	Tri-Clamp x Extended Tube End / SF1 Int. Fin.
D	Tri-Clamp / SF4 Int. Fin.
E	Extended Tube End / SF4 Int. Fin.
F**	Tri-Clamp x Extended Tube End / SF4 Int. Fin.
G**	Extended Tube x Tri-Clamp / SF4 Int. Fin.
H**	Extended Tube x Tri-Camp / SF1 Int. Fin.

Note: SF1 finish is 20 Ra µin (.5 Ra µm) Mechanical Polish, SF4 is 15Ra µin (.4 Ra µm) mechanical/electropolish finish

** See page 5

3 & 4 Operation			
HL	Lever (Std.)		
NN	None		
P1	UT-0A-DA STD		
P2	UT-0-DA STD	S1	UT-0-SR STD
P3	UT-1-DA-STD	S2	UT-1-SR STD
P4	UT-2-DA STD	S3	UT-2-SR STD
P5	UT-2.5-DA STD	S4	UT-2.5-SR STD
P6	UT-3-DA-STD	S5	UT-3-SR STD
P7	UT-3.5-DA STD	S6	UT-3.5-SR STD
P8	UT-4-DA STD	S7	UT-4-SR STD
PF	UT-4.5-DA STD	SF	UT-4.5-SR STD
P9	UT-5-DA STD	S8	UT-5-SR STD
ZZ	Non-Standard		

5 & 6 Actuator Pressure	
40	40 psi
60	60 psi
80	80 psi
NN	N/A (no pneumatic actuator)
ZZ	Non-Standard

7 & 8 Solenoid Feature		
00	None	
3A	3W 8551-120VAC N4 UT-0/5	SR
3C	3W EF8551-120VAC N7 UT-0/5	SR
3J	3W 8317G35-120VAC N4 UT-0/2.5	SR
3M	3W 8321G1-120VAC N4 UT-3/5	SR
3Q	3W EF8317G35-120VAC N7 UT-0/2.5	SR
3R	3W EF8321G1-120VAC N7 UT-3/5	SR
4A	4W 8551-120VAC N4 UT-0A	DA
4B	4W 8551-120VAC N4 UT-0/5	DA
4D	4W EF8551-120VAC N7 UT-0A	DA
4E	4W EF8551-120VAC N7 UT0/5	DA
ZZ	Non-Standard	

N4 = NEMA 4

N7 = NEMA 7

ORDERING SCHEMATIC (CON'T)

Model	Size	Body Mat'l	1	2	3	4	5	6	7	8	9	10	11	12	13	14	15
			/														

9 & 10	Limit Switch
00	None
AA	LS FMYB-5120-N4 to UT-0/3
AB	LS FMYB-5120-N4 to UT-3.5/7
AC	LS AMYB-5120-N7 to UT-0/3
AD	LS AMYB-5120-N7 to UT-3.5/7
AE	LS-AMYB-5120-N4 to Valve
AF	LS AMYB-5120-N7 to Valve
0Z	Non-Standard

11 & 12	Fail Position
NN	Fail Position N/A (No "SR" Actuator)
01	Fail Closed
02	Fail Open

13 & 14	Positioner
00	None
AA	Siemens 760P (3-15 psi), for UT-0/3
AB	Siemens 760P (3-15 psi), for UT-3.5/7
AC	Siemens 760E (4-20 mA), for UT-0/3
AD	Siemens 760E (4-20 mA), for UT-3.5/7
AE	Siemens 2-IQ (4-20 mA) for UT-0/3DA
AF	Siemens 2-IQ (4-20 mA) for UT-3.5/7DA
AQ	Siemens 2-IQ (4-20 mA), for UT-0/3SR
AR	Siemens 2-IQ (4-20 mA), for UT-3.5/7SR
ZZ	Non-Standard

15	Misc. Features
0	None
1	2-Bug Screen 1/8" SST
2	2-Speed Control 1/8" (4-Way)
3	SST Tube & Fittings F/Automation
4	AFR 4Z030A to UT-0-2.5 SST
Z	Non-Standard



Steriflow, a division of Jordan Valve
 3170 Wasson Road • Cincinnati, OH 45209
 513.533.5600 • 800.543.7311 • 513.871.0105 (f)
 steriflow@richardsind.com • www.steriflowvalve.com

Steriflow Valve reserves the right to make revisions to its product, specifications, literature and related information without notice. Please visit our website at www.steriflowvalve.com for the latest information on our products.