

CSDT Series

Compact Sanitary Disc Trap for Clean Environments

The CST Series is a 316L polished, stainless steel thermodynamic disc trap, that is compact with a lightweight design and Tri-Clamp® end connections.

Though non-sanitary in the traditional sense, the exterior is polished to 20 Ra and can be used in clean room environments on plant steam, or non-validated clean steam applications. The thermodynamic action meets the requirements of quick response applications in the steam system. Condensate entry below the disc, concentric to the disc/seat ensures a clean parallel lift of the disc with reference to the seat, eliminating localized wear and tear.

The CSDT is ideal for fluctuating steam loads and pressures. It is virtually maintenance free with a one year replacement warranty.



FEATURES

- 316L body construction
- 20 Ra μ in (0,5 Ra μ m) external mechanical finish (except at body cap junction)
- Operates in any position

ORDERING SCHEMATIC

CSDT210 — 1/2" Tri-Clamp® ends
CSDT310 — 3/4" Tri-Clamp® ends

Contact factory for material and availability of optional end connections

CSDT SERIES Compact Sanitary Disc Trap for Clean Environments

SPECIFICATIONS

Sizes: 1/2" (DN15) & 3/4" (DN20)

Ends: Tri-Clamp®

Materials

- Body: Casting, AISI 316L
- Disc: AISI 316L

Internal Finish: As cast and machined

External Finish: 20 Ra μin (0,5 Ra μm) mechanical finish (except at body/cap junction)

Pressure Maximum Allowable: 227 psig (15,6 barg)

Temperature Maximum Allowable: 842°F (450°C)

Maximum operating back pressure at the outlet should not exceed 80% of the inlet.

Minimum differential pressure for satisfactory operation 3.6 psig.

Note: Thermodynamic disc traps should not be considered drainable in any orientation

DIMENSIONS

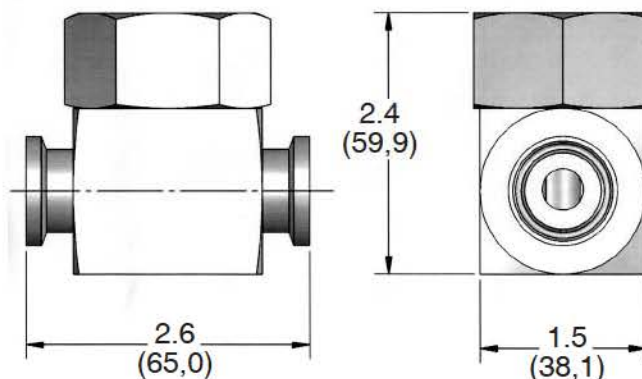

INSTALLATION

The CSDT can be installed any position, but the preferred installation is in the horizontal plane with the cap on top. As with all steam traps, isolation valves should be installed upstream and downstream of the trap for safe maintenance. Always open isolation valves slowly until normal operating conditions are achieved to avoid system shocks.

PREVENTATIVE MAINTENANCE

The CSDT Series can be maintained without disturbing the piping connections. Ensure that the trap is isolated - upstream and downstream - before attempting to dismantle it. Allow the trap to cool before dismantling. Periodic cleaning of the disc and seat will facilitate trouble-free performance. Do not use corrosive media for cleaning. Only the disc and seat are subject to wear. A worn disc can be replaced and slight seat wear can be corrected by resurfacing with a lap plate.

CAPACITY AT DIFFERENTIAL PRESSURE

	bar	1	2	3	4	5	6	7	8	9	10	11	12	13	14	15	16
	psig	14	29	43	58	72	87	101	116	130	145	159	174	188	203	217	232
kg/hr	0	125	200	260	300	340	380	410	440	460	480	500	510	515	520	520	520
pph	0	275	440	572	660	748	836	902	968	1012	1056	1100	1122	1133	1144	1144	1144



Steriflow, a division of Jordan Valve
 3170 Wasson Road • Cincinnati, OH 45209
 513.533.5600 • 800.543.7311 • 513.871.0105 (f)
 steriflow@richardsind.com • www.steriflowvalve.com

Steriflow Valve reserves the right to make revisions to its product, specifications, literature and related information without notice. Please visit our website at www.steriflowvalve.com for the latest information on our products.