

# Mark 65 Series

## Vacuum Regulators

Jordan vacuum regulators control very accurately and shutoff tightly to maintain the proper vacuum setting. They are used to maintain vacuums at predetermined settings and to regulate vacuums on evaporators, cookers, grinding fixtures, milking machines, altitude chambers and other vacuum systems.

### FEATURES

- Sliding gate seats provide:
  - Straight-through flow for reduced turbulence and quiet operation
  - Short stroke for fast response and accurate regulation
  - Easily interchangeable Cv's
  - Tight shutoff
- All metal-to-metal contacts — no gaskets, o-rings or elastomer parts to wear out
- Compact design & simple construction — allows fast, simple installation and easy maintenance

### OPERATION

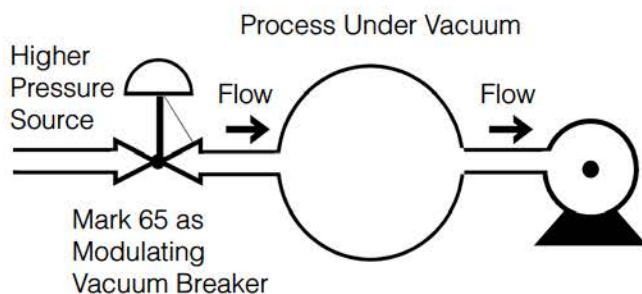

The Mark 65 is normally up and closed. The higher vacuum acts beneath the diaphragm, and lowers the diaphragm on increase in vacuum to open the valve; a decrease in vacuum raises the diaphragm to close the valve. To adjust the set point, the adjusting screw is turned clockwise to increase the vacuum or counter-clockwise to decrease the vacuum.

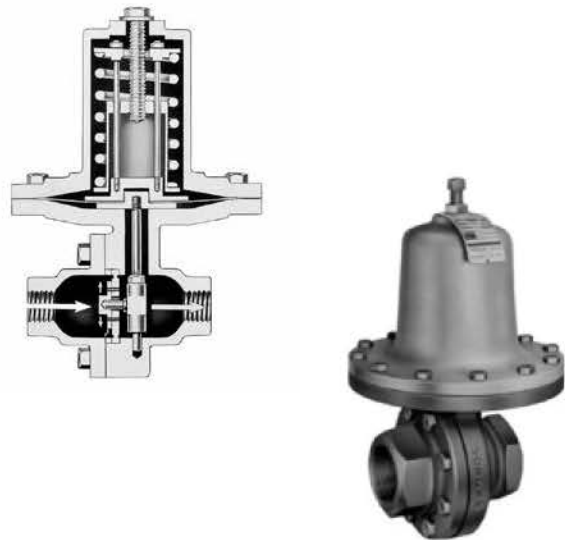

### SPECIFICATIONS

**Sizes:** 1/2" (DN15) through 2" (DN50)  
(Note: 1/4" (DN8) & 3/8" (DN12) use 1/2" (DN15) body with reducer bushings)

#### End Connections:

- Threaded — FNPT, BSPT, BSPP
- ANSI Flanges — 150#, 300#
- DIN Flanges — PN10/16, PN25/40

#### Body Materials:

- Ductile Iron — SA-395
- Bronze — SB-61
- Carbon Steel — SA-216 WCB
- Stainless Steel — SA-351 CF8M

#### Trim Materials:

- 303 SS for DI, BRZ & CS body valves
- 316SS for SS body valves

#### Seat Materials:

- Jorcote on SST – Standard
- Other materials available – Consult factory

#### Diaphragm Materials:

- Stainless Steel (450°F (232°C) temp limit)
- Buna-Nitrile (200°F (93°C) temp limit)
- Viton (450°F (232°C) temp limit)
- Jorlon (450°F (232°C) temp limit)



Jordan Valve, a division of Richards Industries  
3170 Wasson Road • Cincinnati, OH 45209  
513.533.5600 • 800.543.7311 • 513.871.0105 (f)  
info@richardsind.com • www.jordanvalve.com



## MARK 65 VACUUM REGULATORS

### SPECIFICATIONS (CONT'D)

**Spring Housing Materials:** Cast Iron or Ductile Iron

**Service:** Steam, water, oil, gas, air and chemicals

**Shutoff:** ANSI Class IV

**Vacuum Control Ranges:** 1" Hg to 25" Hg vacuum

#### Low Flow Cv's (Kv's) Available

Reduced Cv's (Kv's) can be used in a valve of any size so long as the required Cv (Kv) is a smaller value than the standard for that particular size. In addition, the following Cv (Kv) values can be provided:

1.6 (1,4)	0.84 (0,72)	0.42 (3,36)	0.21 (0,18)	0.08 (0,07)	0.04 (0,03)
0.02 (0,017)	0.008 (0,007)	0.004 (0,003)	0.002 (0,0017)	0.0008 (0,0007) (N/A in 316SS)	

#### Cv (Kv) Values & Maximum Differential Pressure

Flow Coef.*		Valve Size (DN)	Seat Material	Maximum ΔP	
Cv	Kv			PSI	BAR
2.5 or 4.4	2,15 or 3,78	1/2" & 3/4" (DN15 & DN20)	SST	50	3,4
			Jorcote	200	13,8
6.4 or 9.5	5,50 or 8,17	1" & 1-1/4" (DN25 & DN32)	SST	50	3,4
			Jorcote	200	13,8
15	12,9	1-1/2" (DN40)	SST	30	2,1
			Jorcote	150	10,34
25 or 30	21,5 or 25,8	2" (DN50)	SST	30	2,1
			Jorcote	150	10,34

### MAXIMUM WORKING PRESSURES & TEMPERATURES

Maximum Pressure @ 100°F, PSI/°F													
Bolt	Diaph.	DI Body			BRZ Body			CS Body			SST Body		
		150#	300#	TE	150#	300#	TE	150#	300#	TE	150#	300#	TE
Std.	S6	250/100	600/100	300/100	225/100	500/100	300/100	285/100	740/100	300/100	275/100	720/100	300/100
Dbl.	S6	250/100	600/100	600/100	225/100	500/100	500/100	285/100	740/100	950/100	275/100	720/100	950/100
Std.	BN	250/100	300/100	300/100	250/100	300/100	300/100	285/100	300/100	300/100	275/100	300/100	300/100
Std.	VIT	250/100	400/100	300/100	250/100	400/100	300/100	285/100	400/100	300/100	275/100	400/100	300/100
Pressure at Maximum Temperature, PSI/°F													
Std.	S6	125/650	450/650	300/650	150/500	325/500	300/500	125/650	535/650	300/650	125/650	445/650	300/650
Dbl.	S6	125/650	450/650	600/650	150/500	325/500	325/500	125/650	535/650	950/650	125/650	445/650	890/650
Std.	BN	235/200	300/200	300/200	215/200	300/200	300/200	260/200	300/200	300/200	240/200	300/200	300/200
Std.	VIT	235/450	300/450	300/450	160/450	300/450	300/450	185/450	300/450	300/450	180/450	300/450	300/450
Maximum Pressure @ 38°C, BAR/°C													
Bolt	Diaph.	DI Body			BRZ Body			CS Body			SST Body		
		150#	300#	TE	150#	300#	TE	150#	300#	TE	150#	300#	TE
Std.	S6	17/38	41/38	21/38	16/38	34/38	21/38	20/38	51/38	21/38	19/38	50/38	21/38
Dbl.	S6	17/38	41/38	41/38	16/38	34/38	34/38	20/38	51/38	66/38	19/38	50/38	66/38
Std.	BN	17/38	21/38	21/38	17/38	21/38	21/38	20/38	21/38	21/38	19/38	21/38	21/38
Std.	VIT	17/38	28/38	21/38	17/38	28/38	21/38	20/38	28/38	21/38	19/38	28/38	21/38
Pressure @ Maximum Temperature, BAR/°C													
Std.	S6	9/343	31/343	21/343	10/260	22/260	21/260	9/343	37/343	21/343	9/343	31/343	21/343
Dbl.	S6	9/343	31/343	41/343	10/260	22/260	22/260	9/343	37/343	66/343	9/343	31/343	61/343
Std.	BN	16/93	21/93	21/93	15/93	21/93	21/93	18/93	21/93	21/93	17/93	21/93	21/93
Std.	VIT	16/232	21/232	21/232	11/232	21/232	21/232	13/232	21/232	21/232	12/232	21/232	21/232

DIMENSIONS

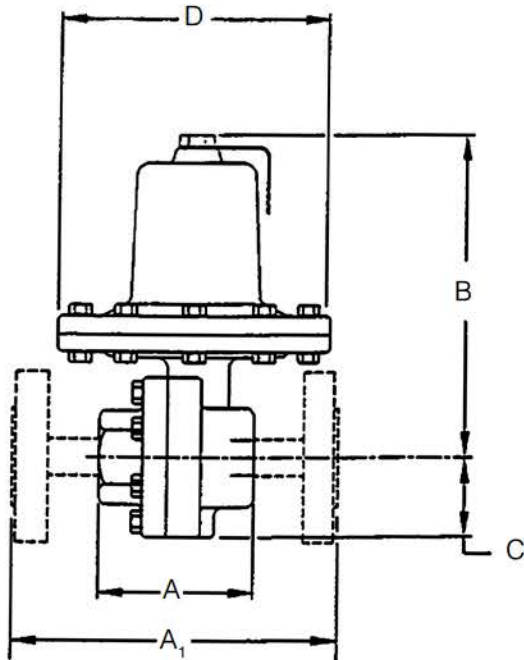

• Flanged Ends

Size	ANSI Flange	Dimensions (inches)						Weight (lbs.)	
		A <sub>1</sub>		B		C	D	DI/BRZ	CS/SS
		DI/BRZ	CS/SS	DI/BRZ	CS/SS	ALL	ALL		
1/2"	150#	7.25	7.25	8.25	8.25	2.25	7.12	24	25
	300#	7.50	7.50	8.25	8.25	2.25	7.12	26	27
3/4"	150#	7.25	7.25	8.25	8.25	2.25	7.12	26	27
	300#	7.62	7.62	8.25	8.25	2.25	7.12	28	29
1"	150#	7.25	7.25	8.50	9.00	2.65	7.12	29	29
	300#	8.75	7.75	8.50	9.00	2.65	7.12	31	31
1 1/4"	150#	7.87	—	8.50	—	2.25	7.08	29	—
	300#	8.37	—	8.50	—	2.25	7.08	33	—
1 1/2"	150#	8.75	8.75	8.75	9.25	2.65	7.08	34	37
	300#	10.25	9.25	8.75	9.25	2.65	7.08	40	43
2"	150#	10.00	10.00	9.00	9.25	2.75	7.08	40	45
	300#	10.50	10.50	9.00	9.25	2.75	7.08	44	49

• Threaded Ends

Size	Material	Dimensions (inches)				Weight (lbs.)
		A	B	C	D	
1/2" & 3/4"	DI/BRZ	3.62	8.25	2.25	7.12	22
	CS/SS	3.62	8.25	2.25	7.12	23
1"	DI/BRZ	4.12	8.50	2.25	7.08	25
	CS/SS	4.18	9.0	2.65	7.12	25
1 1/4"	DI/BRZ	4.12	8.50	2.25	7.08	25
1 1/2"	DI/BRZ	4.50	8.75	2.37	7.08	23
	CS/SS	4.81	9.25	2.65	7.08	26
2"	DI/BRZ	4.50	9.00	2.50	7.08	26
	CS/SS	5.50	9.25	2.75	7.08	35

• Flanged Ends, DIN

Size (DN)	Flange (PN)	Dimensions (mm)						Weight (kg)	
		A <sub>1</sub>		B		C	D	DI/BRZ	CS/SS
		DI/BRZ	CS/SS	DI/BRZ	CS/SS	ALL	ALL		
15	10/16	184	130	210	210	57	181	10,9	11,3
	25/40	184	130	210	210	57	181	11,8	12,2
20	10/16	184	150	210	210	57	181	11,8	12,2
	25/40	184	150	210	210	57	181	12,7	13,2
25	10/16	184	160	216	229	67	181	13,2	13,2
	25/40	184	160	216	229	67	181	14,1	14,1
32	10/16	200	—	216	—	57	180	13,2	—
	25/40	200	—	216	—	57	180	15,0	—
40	10/16	222	200	222	235	67	180	15,4	16,8
	25/40	222	200	222	235	67	180	18,1	19,5
50	10/16	254	230	229	235	70	180	18,1	20,4
	25/40	254	230	229	235	70	180	20,0	22,2

• Threaded Ends, DIN

Size (DN)	Material	Dimensions (mm)				Weight (kg)
		A	B	C	D	
15 & 20	DI/BRZ	92	210	57	181	10,0
	CS/SS	92	210	57	181	10,4
25	DI/BRZ	105	216	57	180	11,3
	CS/SS	106	229	67	181	11,3
32	DI/BRZ	105	216	57	180	11,3
40	DI/BRZ	114	222	60	180	10,4
	CS/SS	122	235	67	180	14,1
50	DI/BRZ	114	229	64	180	13,6
	CS/SS	140	235	70	180	15,9



**ORDERING SCHEMATIC**

To specify a MK65 Series Vacuum Regulator, build a model number by making a selection from each category in the product Designator Coding System below.

<b>1</b>	-	<b>2</b>	-	<b>3</b>	/	<b>4</b>	<b>5</b>	<b>6</b>	<b>7</b>	<b>8</b>	<b>9</b>

<b>1</b>	<b>Model</b>	
65	Model	

<b>2</b>	<b>Size</b>		
	<b>Inches</b>	<b>DN</b>	
025	1/4"	DN8	
038	3/8"	DN10	
050	1/2"	DN15	
075	3/4"	DN20	
100	1"	DN25	
125	1-1/4"	DN32	
150	1-1/2"	DN40	
200	2"	DN50	

<b>3</b>	<b>Body Material</b>	
DI	Ductile Iron	
BR	Bronze	
CS	Carbon Steel (WCB)	
S6	Stainless Steel (CF8M)	

<b>4</b>	<b>End Connections</b>	
PT	NPT	
BT	BSPT	
BP	BSPB	
SW	FSW	
I5	150# IFE CS or SST valves	
F5	150#FE (Except IFE)	
I3	300# IFE CS or SST valves	
F3	300# FE DI or BR	
I7	PN10 IFE CS or SST valves	
F7	PN10 FE DI or BR	
I6	PN16 IFE CS or SST valves	
F6	PN16 FE DI or BR	
I8	PN25 IFE CS or SST valves	
F8	PN25 FE DI or BR	
I4	PN40 IFE CS or SST valves	
F4	PN40 FE DI or BR	

<b>5</b>	<b>Trim</b>	
S3	303SS	
S6	316SS	
I3	303SST for integral flanges (IFE)	
I6	316SST for integral flanges (IFE)	

<b>6</b>	<b>Seat Material</b>	
A	303SST	
B	316SST	
V	303SS / Jorcote	
W	316SS / Jorcote	

<b>7</b>	<b>Cv (Kv)</b>			
1	0.21 (0,18)	7	6.4 (5,52)	
2	0.42 (0,36)	8	9.5 (8,19)	
3	0.84 (0,72)	9	15.0 (12,93)	
4	1.6 (1,38)	A	25.0 (21,55)	
5	2.5 (2,16)	B	30.0 (25,86)	
6	4.4 (3,79)			

<b>8</b>	<b>Range</b>	
01	1-20" Hg	
0B	1-25" Hg	

<b>9</b>	<b>Diaphragm</b>	
S6MD	316 SST	
BNED	Buna-N	
V1ED	Viton	
JLED	Jorlon	

