

Master Wall Inc.®



BUILDING PROTECTION SOLUTIONS





The Master Wall Inc.® SuperiorShield Building Solutions are your one-stop shop for air and water protection for your buildings. Our products are designed to work seamlessly with one another as part of a comprehensive air and water protection strategy. These Fluid-Applied Air and Water Barrier systems offer extremely low air leakage ratings with excellent water holdout. The centerpiece of this application is our Rollershield fluid-applied product that easily covers 100% of the surface area for complete building protection.

When it comes to keeping your building dry, you want 100% protection, and you can't settle for less. Sheet water barriers have laps, gaps, and are secured with fasteners. Mechanical attachment requires puncturing the substrate hundreds or even thousands of times. At windows and doors, peel-and-stick flashings don't seal properly or lose bond over time. The SuperiorShield Air and Water Barrier System is a fluid-applied, secondary water barrier and flashing that offers 100% coverage with no laps, breaks, or holes. It seals the substrate and protects the building. Like people, buildings breathe and are continuously passing water vapors around depending upon interior and exterior conditions.

The critical advantages of SuperiorShield Building Solutions are:

- Monolithic: No laps, breaks or holes. This feature eliminates the risk of incidental moisture intrusion through laps or breaks.
- Continuous: Will not pull away due to wind or tearing which can cause exposure to moisture and air leakage.
- Adhesive-Attachment: No fasteners required. Fasteners can create breaks in non-fluid applied barriers and the substrate.
- Fire Testing: This system has been tested to meet the standards of the NFPA 285 Fire Test and can be used on fire-resistance-rated construction assemblies.
- Multi-functional: Products can be used as a barrier with Master Wall® EIFS, brick, siding, stucco, stone, and panels.

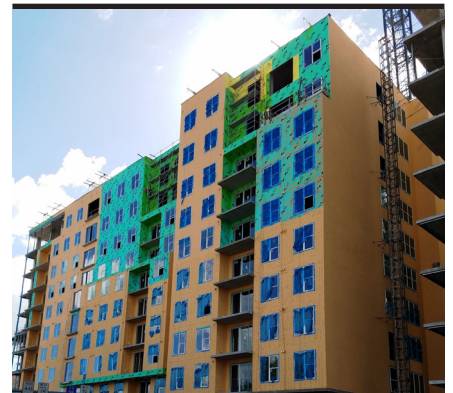
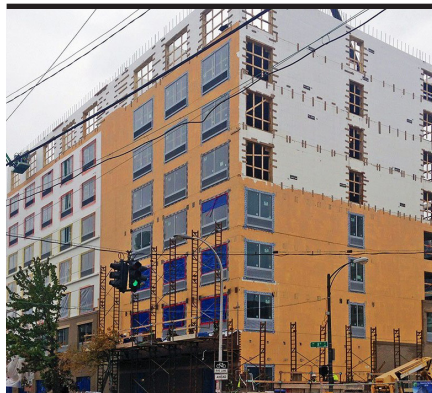

For use with multiple claddings and wall construction types

Claddings

EIFS



Stucco



Brick



Stone



Metal Wall Panels



Siding

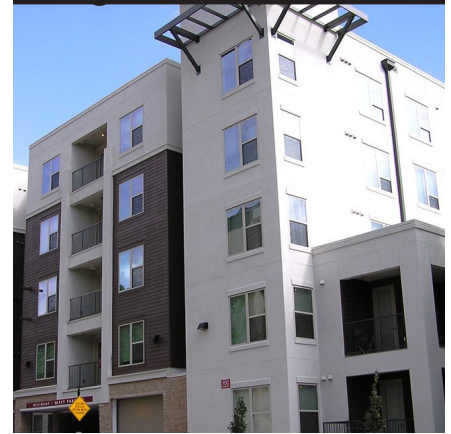

Wall Construction Types

Framed/Sheathed



CMU



ICF

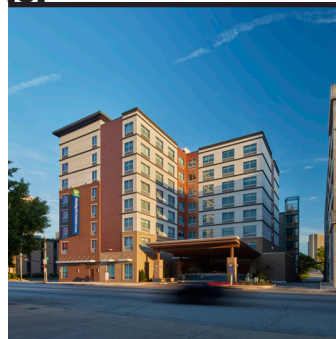

Precast



Master Wall® SuperiorShield Products



SuperiorShield Rollershield (RS)



Rollershield-RS is a high quality 100% acrylic flexible air and water barrier. Rollershield-RS is intended for roller or spray application but also can be troweled or brushed into place. Rollershield-RS forms a continuous air and water barrier that protects approved substrates from incidental water damage. Rollershield RS is Vapor Permeable and is used as a Water Barrier and a flashing material when used with RS Flashing Tape.

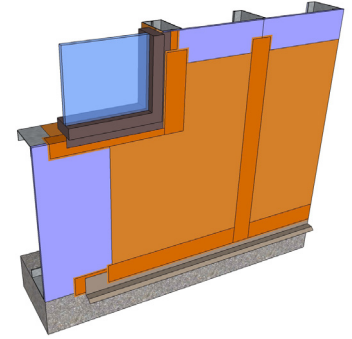

SuperiorShield Trowel Grade (TG)



Rollershield-TG is a high quality 100% acrylic flexible air and water barrier. Rollershield-TG is the trowel grade version of Rollershield RS and can be used for filling large gaps or leveling large areas in the Rollershield LAB system application. Rollershield-TG forms a continuous air and water barrier that protects approved substrates from incidental water damage. Rollershield TG is Vapor Permeable and is used as a Water Barrier and a flashing material when used with RS Flashing Tape.

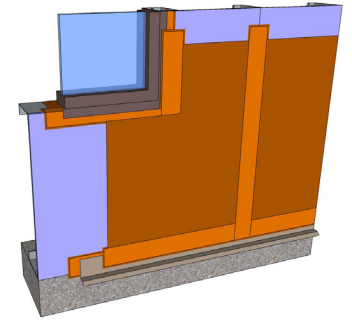

SuperiorShield Vapor Barrier (VB)

Rollershield-VB is the vapor barrier version of our Rollershield Liquid applied Air and Water Barrier (LAB). Rollershield-VB is a high quality roll applied flexible air and water barrier. Easily applied with a trowel, brush, roller, hopper gun or airless sprayer. Rollershield-VB forms a continuous air and water barrier that protects approved substrates from incidental water damage. Rollershield VB is a Vapor Blocker and is used as a Water Barrier and a flashing material when used with RS Flashing Tape.

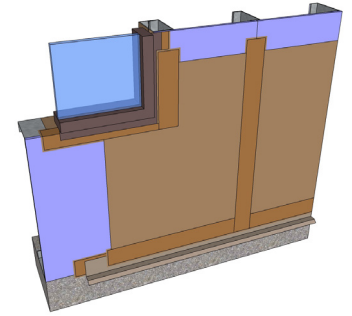

SuperiorShield Guardian A.M.B., Base Coat and Adhesive

To finish strong you need a Superior Base Coat that can not only protect but waterproof the surface. Premium Guardian is formulated with waterproof polymers and embeds easily into Master Wall mesh as part of a weather protection strategy. Guardian can be used as a below grade waterproofing agent as well as the initial barrier in CMU waterproofing applications above grade.

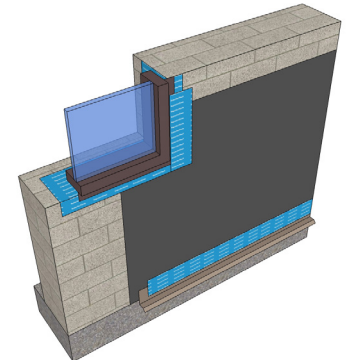

SuperiorShield WeatherSTOP

WeatherSTOP leveling base coat is formulated for superior weather resistance to stop water before it enters your stucco or wall. Flexible, fibered WeatherSTOP remains flexible, weather resistant and embeds easily into Master Wall® mesh. WeatherSTOP is an alternative to a separate fluid applied water barrier. WeatherSTOP blocks water before it soaks the stucco keeping your building dry. WeatherSTOP bridges minor hairline cracks, is flexible, levels the surface, and can be used as a base coat to create a smooth surface for finishing.

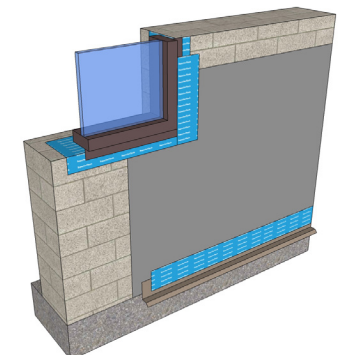

Master Wall® SuperiorShield Flashings and Accessories



SuperiorShield SuperiorFlash

Master Wall Inc.® SuperiorFlash is a gun-grade flashing and waterproofing. Formulated with STPE polymers, SuperiorFlash uses moisture curing to produce a highly durable, seamless, elastomeric flashing membrane. Fast curing, it allows for same day installation of windows, doors and other wall assembly, waterproofing or air barrier components. SuperiorFlash bonds directly to damp or dry surfaces and cures under a variety of weather conditions.

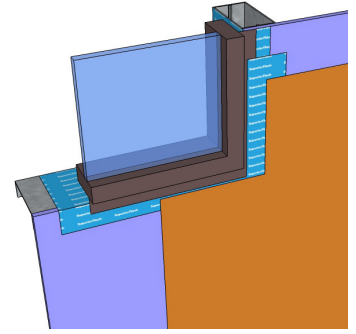

SuperiorShield Flashing Tape

Rollershield Flashing Tape is a lightweight roll flashing material with superior strength and the ability to bridge most gaps or voids common in construction. Embedded into wet Rollershield, it is used at flashing transitions with Master Wall® Rollershield air & water barrier applications. The tape easily embeds into wet Rollershield and dries to a highly reinforced yet flexible flashing.

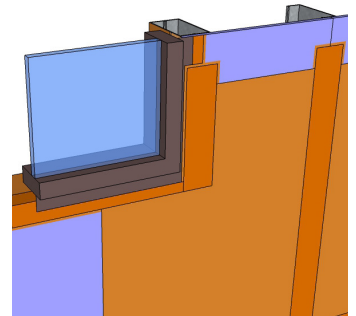

SuperiorShield Mesh

Master Wall Rollershield Mesh is a self-adhesive, lightweight, woven fiberglass mesh specially coated for compatibility with Master Wall Rollershield products. The self-adhesive properties allow easier application with Rollershield.

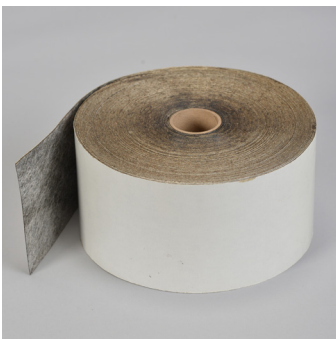
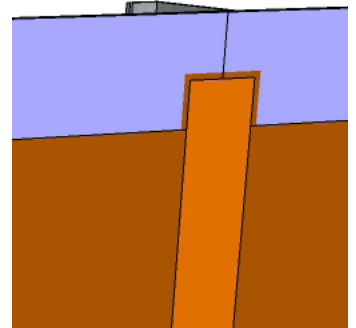

SuperiorShield WeatherSTOP Tape

WeatherStop Tapes are a peel and stick type flashing with self-sealing properties and a polyester scrim facing designed for use with Master Wall® Systems. The tapes feature low initial grab for repositioning that gradually increases over time.

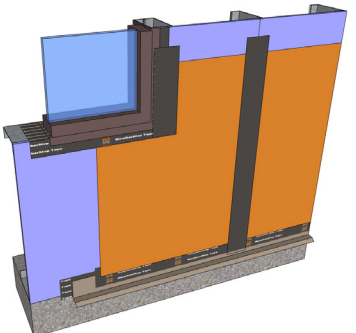

SuperiorShield Drainage Venting Roll

Master Wall DV Roll is a lightweight corrugated plastic designed for use where drainage or venting is required without the use of heavy plastic accessories. DV Roll can be used with back wrapped application techniques in Master Wall EIFS and as part of a compartmentalized venting assembly.

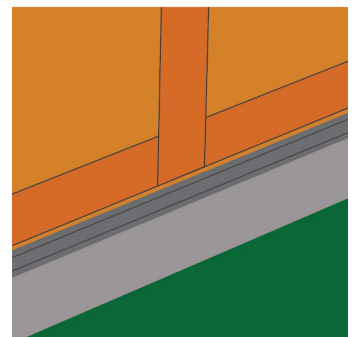

TEST	METHOD	CRITERIA	RESULT
Tensile Bond	ASTM C297/E2134, ICC ES (AC 212)* ICC ES (AC 212)*	Minimum 15 psi (104 kPa)	Dens Glass Gold 31 (215), Exterior Gypsum 28 (194), OSB 40 (277), Plywood 79 (563), Cement Board 70 (485), Copper 185 (1282), Galvanized steel 180 (1248), PVC 168 (1165), Aluminum 184 (1275), Coated Aluminum 203 (1407), Stainless Steel 183 (1269)
Freeze-Thaw	ASTM E2485/ICC-ES Proc. ICC ES (AC 212)*	No deleterious effects after 10 cycles	Pass: Plywood, Cement Board, OSB, Exterior Gypsum (ASTM C79/C1396) and Dens Glass Gold (ASTM C1377) substrates
Water Resistance	ASTM D2247 ICC ES (AC 212)*	No deleterious effects after 14 days exposure ¹	Pass: Plywood Cement Board, OSB, Exterior Gypsum (ASTM C79/C1396) and Dens Glass Gold (ASTM C1377) substrates
Water Vapor Transmission	ASTM E96 Proc. B ICC ES (AC 212)*	Vapor Permeable	30 perms (Rollershield RS) ² 12 perms (Rollershield TG) 0.007 perms (Rollershield VB)
Air Permeance	ASTM E2178	No ICC or ANS/EIMA Criteria ASHRAE/IECC max 0.04 cfm/ft ² @ 1.57 psf	0.001 cfm/ft ² @ 1.57 psf 0.001 L/s/m ² @ 75 Pa
Air Leakage	ASTM E2357	No ICC or ANS/EIMA Criteria ASHRAE/IECC max 0.04 cfm/ft ² @ 1.57 psf	0.0006 cfm/ft ² @ 1.57 psf 0.003 L/s/m ² @ 75 Pa 0.04 cfm/ft ² @ 6.24 psf 0.02 L/s/m ² @ 300 Pa
Structural Performance	ASTM E1233 Proc. A ICC ES (AC 212)*	Minimum 10 positive cycles at 1/240 deflection; No cracking in field, at joints or interface with flashing	Pass
Racking	ASTM E72 ICC ES (AC 212)*	No cracking in field, at joints or interface with flashing at net deflection of 3.2 mm (1/8 inch)	Pass
Restrained Environmental	ICC ES Procedure ICC ES (AC 212)*	5 cycles: No cracking in field, at joints or interface with flashing	Pass
Water Penetration	ASTM E331 ICC ES (AC 212)*	No water penetration beyond the inner-most plane of the wall after 15 minutes at 137 Pa (2.86 psf)	Pass
UV Exposure	ICC ES Proc. ICC ES (AC 212)*	210 hours of exposure	Pass
Accelerated Aging	ICC ES Proc. ICC ES (AC 212)*	25 cycles of wetting and drying	Pass
Hydrostatic Pressure Test	AATCC 127 ICC ES (AC 212)*	ICC: 549 mm (21.6 in) water column for 5 hours	Pass
Surface Burning Characteristics	ASTM E84	Flame Spread < 25 Smoke Developed < 450	Pass
Intermediate Multi-Story Fire Test	NFPA 285 (UBC 26-9)	No flame spread with up to 4" insulation	Pass
Nail Sealability	ASTM D1970	Standard Specification for Self-Adhering Polymer Modified Bituminous Sheet Materials Used as Steep Roofing Underlayment for Ice Dam Protection	Pass (22 mills)

* AC212 – Acceptance Criteria for Water-Resistive Coating Used as Water-Resistive Barriers over Exterior Sheathing, also referred to as ASTM E 2570

1. No cracking, checking, rusting, crazing, erosion, blistering, peeling or delamination when view under 5x magnification

2. Defined as a Class III vapor retarder per the 2015 IBC and IRCv

Master Wall® Mission

- To manufacture the highest-quality EIFS, stucco and related products (coatings, adhesives, etc.) available in the market.

- To be the service leader of our industry in the region and areas where we market our products.

- To be respected in our industry because of honesty and integrity within our ranks.

- To encourage our employees to set the highest standards possible for their careers and their personal lives by supporting them through education, training and sharing any God-given wisdom we may obtain.

- To compensate all employees in such a way that they can support themselves and their families in a comfortable manner.

- To seek God's guidance in all decisions, and to give Him glory for any results.

WE FINISH STRONG.



Corporate Office

P.O. Box 397
Fortson, GA 31808
800-755-0825
FAX 706-569-6704
Email: corporate@masterwall.com

Georgia Manufacturing

2265 Lithonia Industrial Boulevard
Lithonia, GA 30058
800-755-0824
FAX 770-482-9617

Utah Manufacturing

810 West Utah Avenue #1
Payson, UT 84651
888-492-0023
FAX 801-465-1129

Texas Manufacturing

979 Brazos Crossing Circle
Sealy, TX 77474
979-885-6905

Indiana Office

72-1/2 West Main Street
Suite #2
Danville, IN 46122
888-313-9966
FAX 317-745-0321

Technical Service

800-760-2861
tech@masterwall.com

