



FREE FLOAT® STEAM TRAP

MODEL J5X

FREE FLOAT STEAM TRAP WITH THERMOSTATIC AIR VENTING

Benefits

Extremely durable, inline repairable free float trap with tight shut-off for drainage of small to medium size process loads.

1. Self-modulating free float provides soft, continuous, smooth, low velocity discharge, as process loads vary, for maximum performance.
2. Unique rotational seating design eliminates concentrated wear to provide long maintenance-free service life.
3. Durable thermostatic unit automatically vents air for exceptional start-up and performance.
4. Easy, inline access to internal parts simplifies cleaning and lowers maintenance costs.
5. Rugged float construction with up to 1740 psig hydraulic shock rating ensures excellent resistance to water hammer.
6. Built-in screen with large surface area ensures extended trouble-free service.



Specifications

Model	J5X	JF5X
Connection	Screwed	Flanged
Size (in)	¾, 1, 1½	2
Orifice No.	2, 5, 10, 21	2, 5, 10
Maximum Operating Pressure (psig) PMO	30, 75, 150, 300	30, 75, 150
Maximum Differential Pressure (psi) Δ PMX	30, 75, 150, 300	30, 75, 150
Minimum Operating Pressure (psig)	Vacuum	
Maximum Operating Temperature (°F) TMO	428	
Maximum Allowable Pressure (psig) PMA	300	250
Maximum Allowable Temperature (°F) TMA	428	



To avoid abnormal operation, accidents or serious injury, DO NOT use this product outside of the specification range. Local regulations may restrict the use of this product to below the conditions stated.

Connections and sizes in bold are standard

No.	Description	Material	ASTM/AISI*	JIS
①	Body (J5X)	Ductile Cast Iron	A536	FCD450
	Body (JF5X)	Cast Iron	A842 Gr.400	FCV410
②	Cover	Ductile Cast Iron	A536	FCD450
③ ^F	Float	Stainless Steel	AISI316L	SUS316L
④	Orifice Holder Plug	Carbon Steel	AISI1025	S25C
⑤ ^{MR}	Orifice Plug Gasket	Fluorine Resin	PTFE	PTFE
⑥ ^R	Orifice	—	—	—
⑦ ^{MR}	Orifice O-Ring	Synthetic Rubber	D2000CA	EPR
⑧ ^R	Screen	Stainless Steel	AISI430	SUS430
⑨ ^{MR}	Cover Gasket	Fluorine Resin	PTFE	PTFE
⑩	Nameplate	Stainless Steel	AISI304	SUS304
⑪ ^R	Float Cover	Stainless Steel	AISI304	SUS304
⑫ ^R	X-element Guide	Stainless Steel	AISI304	SUS304
⑬ ^R	X-element	Stainless Steel	—	—
⑭ ^R	Spring Clip	Stainless Steel	AISI304	SUS304
⑮ ^R	Air Vent Valve Seat	Stainless Steel	AISI420F	SUS420F
⑯	Connector	Stainless Steel	AISI416	SUS416
⑰	Cover Bolt	Carbon Steel	AISI1045	S45C
⑱	Plug	Carbon Steel	AISI1025	S25C
⑲ ^{MR}	Plug Gasket	Fluorine Resin	PTFE	PTFE
⑳	Drain Plug**	Carbon Steel	AISI1025	S25C
㉑	Drain Plug Gasket**	Soft Iron	AISI1010	SUYP

* Equivalent ** Option

Replacement kits available: (M) maintenance parts, (R) repair parts, (F) float

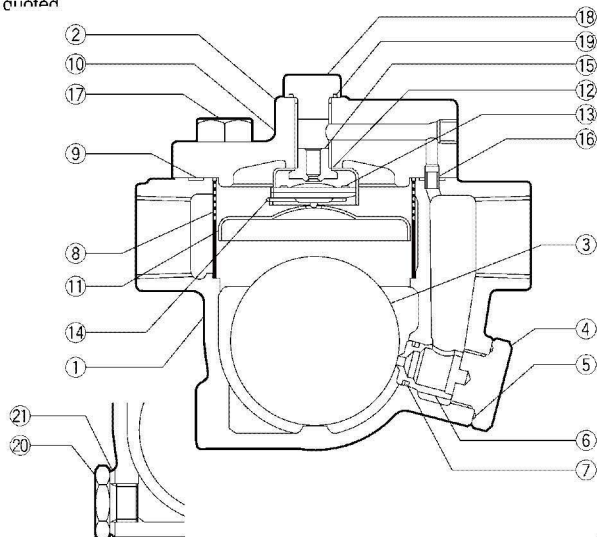

Dimensions

● **J5X** Screwed

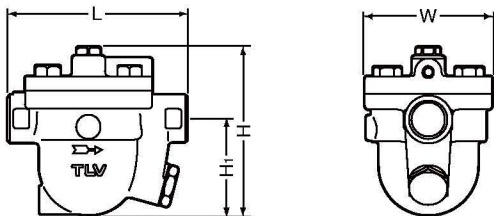

J5X Screwed* (in)

Size	L	H	H ₁	W	Weight (lb)
3/4	6 1/8	5 7/8	3 5/16	4 1/4	9.7
1					9.5
1 1/2	6 5/16	7 3/16	4 3/16		13

* NPT, other standards available

● **JF5X** Flanged

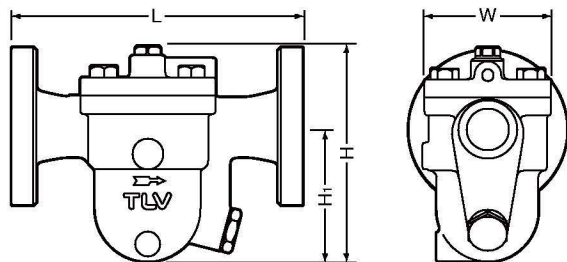

JF5X Flanged (in)

Size	L		H	H ₁	W	Weight* (lb)
	Connects to 125FF	ASME Class 250RF				
2	10 1/8	10 5/8	7 3/4	4 11/16	4 1/4	27

Other standards available, but length and weight may vary
* Weight is for Class 250 RF

Discharge Capacity

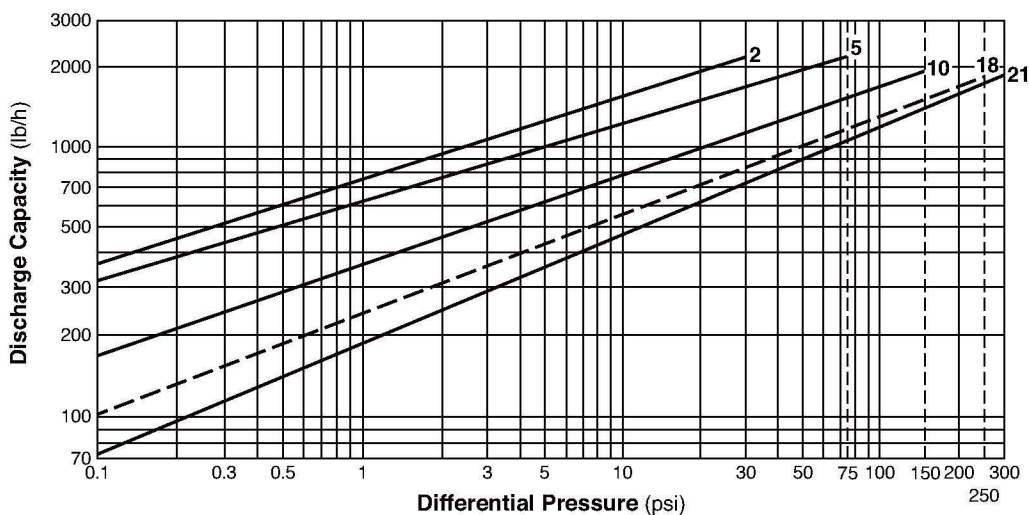

— Standard - - - - - Available on special request (only for JF5X).

1. Line numbers within the graph refer to orifice numbers.
2. Differential pressure is the difference between the inlet and outlet pressure of the trap.
3. Capacities are based on continuous discharge of condensate 11°F below saturated steam temperature.
4. Recommended safety factor: at least 1.5.

CAUTION DO NOT use traps under conditions that exceed maximum differential pressure, as condensate backup will occur!

CAUTION DO NOT DISASSEMBLE OR REMOVE THIS PRODUCT WHILE IT IS UNDER PRESSURE. Allow internal pressure of this product to equal atmospheric pressure and its surface to cool to room temperature before disassembling or removing. Failure to do so could cause burns or other injury. READ INSTRUCTION MANUAL CAREFULLY.

TLV CORPORATION

13901 South Lakes Drive, Charlotte, NC 28273-6790
 Phone: 704-597-9070 Fax: 704-583-1610
 E-mail: tlv@tlvengineering.com
 For Technical Service 1-800 "TLV TRAP"



Manufacturer
TLV CO., LTD.
 Kakogawa, Japan
 is approved by LRQA Ltd. to ISO 9001/14001

ISO 9001/ISO 14001

