

Mark 75PTP Series

CRN Registration Number Available

Piston Operated Wafer Style Control Valves

The Mark 75PTP is a Mark 75 wafer style control valve with an 80mm (1" - 2") Stainless Steel Piston Actuator. The Gemu cPOS Smart Positioner is standard and required for control applications. For on/off service, the valve may be supplied without a positioner. JVCV Should be used for sizing selection.

CAPACITY

The Mark 75PTP provides great capacity in a compact wafer style body. A 2" Mark 75PTP provides 72 Cv (62 Kv). (Refer to Cv Capacity Charts for information concerning all line sizes).

EASE OF MAINTENANCE

The Mark 75PTP features a 'T' slot design connection to the disc. This connection allows for quick and easy reversing of functions. Instead of having to go into the actuator to change action, all that is needed in a Mark 75PTP is to rotate the seats 180°. With this simple rotation, the valve can go from reverse acting to direct acting (or vice versa).

The stroke length of the Mark 75PTP is a slightly longer stroke than standard sliding gate valves. This longer stroke enables better turndown. Combined with the capacity of the Mark 75PTP, the increased turndown makes for a great control valve.



Control Valves

Mark 75PTP Wafer Style Control Valves



Jordan Valve a division of Richards Industries
3170 Wasson Road • Cincinnati, OH 45209
513.533.5600 • 800.543.7311 • 513.871.0105 (f)
info@richardsind.com • www.jordanvalve.com

SPECIFICATIONS

Sizes: 1" (DN25), 1-1/2" (DN40), 2" (DN50)

Body Materials

- A105 CS barstock or SA-479 Bar 316/316L SS barstock

Body Seals:

- Jorlon plate/body gasket, PTFE spring loaded teflon v-ring packing

Trim Material

- 316 Stainless Steel

Seat Materials

- Jorcote/316SS – standard

Shut Off: Class IV

End Connections: ANSI 150/300 WAFER

Yoke Materials

- Ductile Iron (1" - 2")
- NAMUR Cast Iron

Actuator Case Material: Stainless Steel

Packing Material

- Spring loaded Teflon V-Ring to 500°F (260°C)
- Grafoil above 500°F (260°C)

Maximum Pressure Drop: 125 psi with standard Piston Actuator and Spring

Ranges: 12.7-14.7 psi for 1", 12.7-16.7 psi for 1-1/2", 12.7-19.1 psi for 2"

* positioner required

Action

- Direct (ATC)
- Reverse (ATO)

Actuator

- Direct mount pneumatic piston

Turndown Ratio Capability: 100:1

PRESSURE/TEMPERATURE CHART

Carbon Steel

Stainless Steel

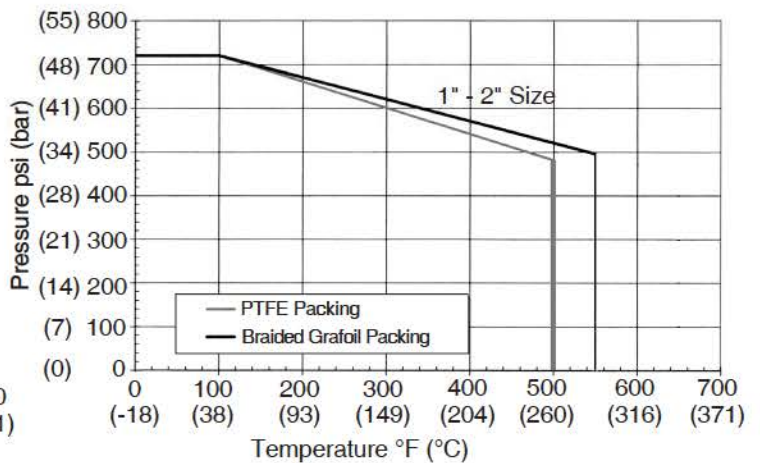
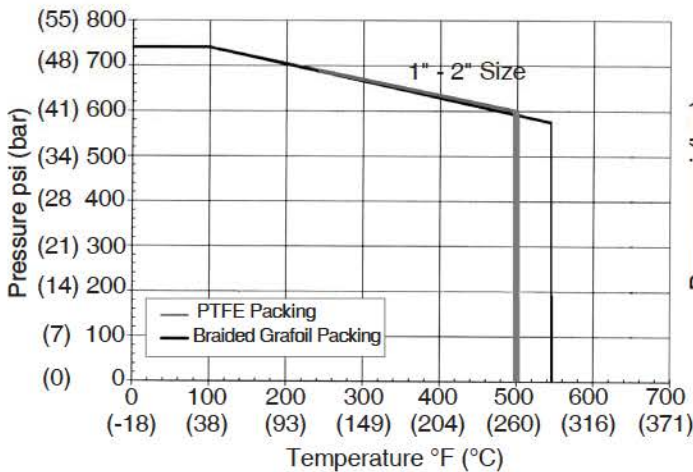

Cv/Kv vs TRAVEL – LINEAR

Cv (Kv)	Flow Characteristics	10%	20%	30%	40%	50%	60%	70%	80%	90%	100%
9.5 (8,2)	Linear	0.95	1.90	2.85	3.8	4.75	5.70	6.65	7.60	8.55	9.5
33 (28)	Linear	3.3	6.6	9.9	13.2	16.5	19.8	23.1	26.4	29.7	33
38 (33)	Linear	3.8	7.6	11.4	15.2	19.0	22.8	26.6	30.4	34.2	38
72 (62)	Linear	7.2	14.4	21.6	28.8	36.0	43.2	50.4	57.6	64.8	72

Cv vs Travel curves represent projected performance based on file data. Actual results may vary from system to system.

Cv (Kv) VALUES

Size	DN	Linear Cv	Linear Kv
1"	DN25	9.5	8,2
1-1/2"	DN40	33	28
2"	DN50	38	33
		72	62

CF = Consult Factory for Equal Percentage Requirements

MAXIMUM Δ RATINGS, PSI (BAR) WITH POSITIONER

Size	Actuator	Teflon	Jorcote
1" – 2"	35M	175 (12,1)	200 (13,8)

Note: 25 psi (1,7 bar) air supply for ATC, 45 psi (3,1 bar) for ATO (35 min, 45 max)

SLIDING GATE FEATURES & BENEFITS

Jordan Valve's Sliding Gate Seats

Installed in the widest range of gas, chemical and steam applications the world over, our pressure regulators, temperature regulators and control valves have been providing the following benefits for over fifty years.

Shorter stroke length than globe or cage designs

- Provides faster response to input signal changes
- Significantly extends packing and diaphragm life
- Allows for more compact valve/actuator assembly

Straight-through flow

- Significantly reduces turbulence, thereby reducing noise and erosion
- Markedly increases rangeability associated with "flow to open" and "flow to close" designs
- Eliminate valve "chatter" commonly observed when valve is partially open

Ease of maintenance

- During seat/Cv change (seats are not screwed or pressed in body)
- Attributable to lightweight, compact design
- Fewer trim components

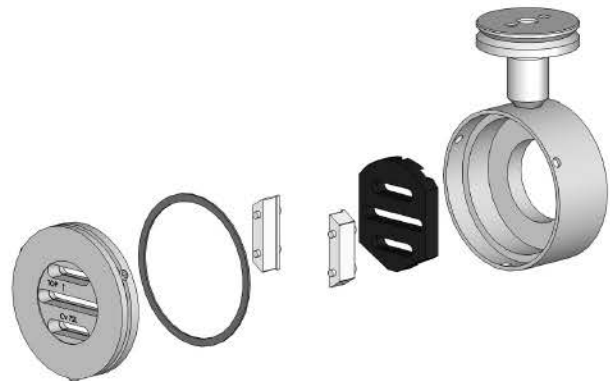

Features

- Easy installation between flanges with wafer body
- High flow rates
- Self cleaning, self lapping seats
- Reduced noise compared to conventional globe/cage valves
- More resistant to cavitation / flashing with straight through, wafer design

1" THRU 2" MARK 75PTP SERIES WITH OPTIONAL 4" STEM EXTENSION

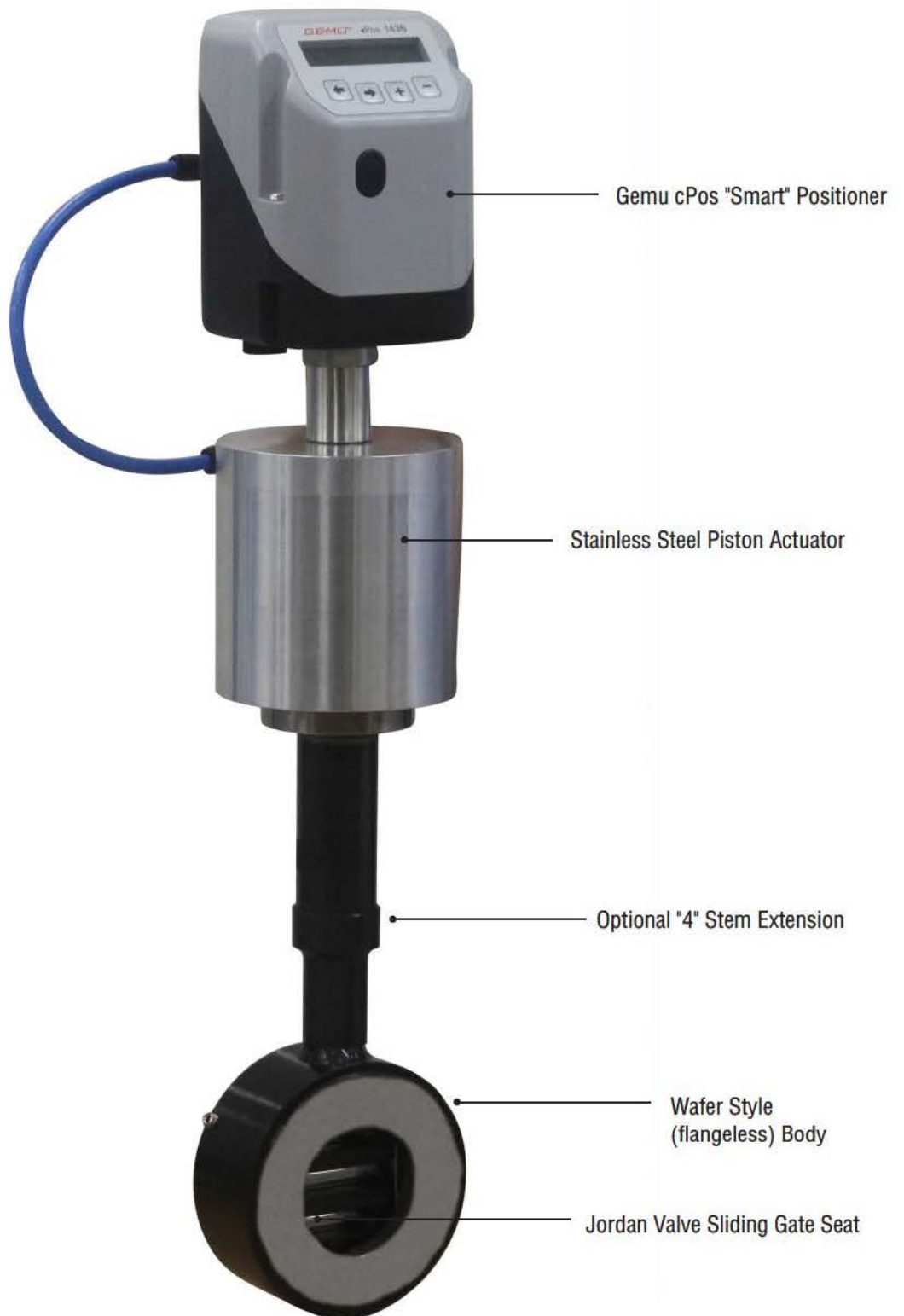

DIMENSIONS – MK75PTP

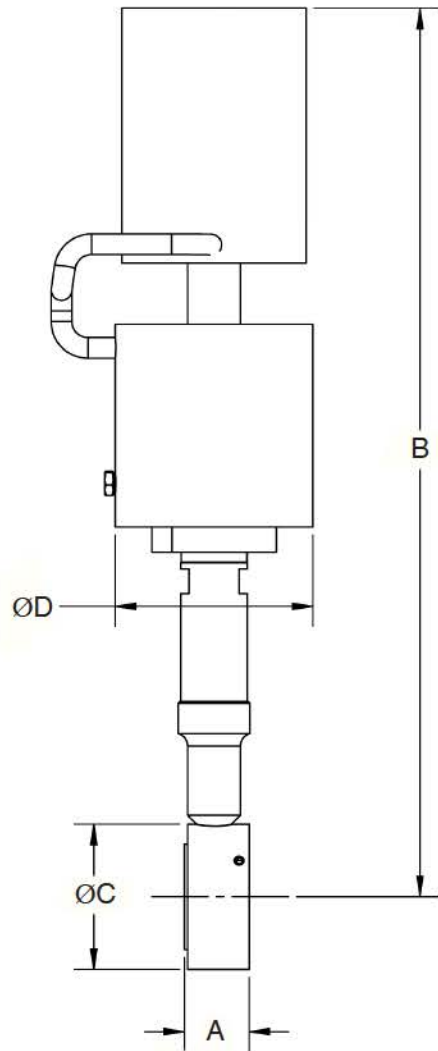

INCHES

Valve Size	Dimensions, Inches			
	A	B	C	D
1"	1.24	16.86	2.75	3.75
1-1/2"	1.30	17.34	3.24	3.75
2"	1.69	17.56	3.97	3.75

MARK 75PTP SERIES WAFER STYLE CONTROL VALVES

ORDERING SCHEMATIC MARK 75PTP

Model No	Size	Body Mat'l	1	2	3	4	5	6	7	8	9	10	11	12	13

Model	
75PTP	Standard

Size	
100	1"
150	1-1/2"
200	2"

Body Material	
CB	Carbon Steel Bar
SB	Stainless Steel Bar

End Connections	
I3	150# / 300# IFE

Trim	
G6	TFE / 316 5 IN
ZZ	Non-Standard

Seats			
	Material	Cv	
W	316 / JOR	4	1.6
		6	4.4
		7	6.4
		8	9.5
		A	33
		B	38
		E	72
ZZ	Non-Standard		

Range			
75PTP			
Range		Actuator	
		B4	4 - 20 mA
		B9	0 - 10V
ZZ	Non-Standard		

Actuator	
B7	80mm Piston
ZZ	Non - Standard

Action	
ØD	Air-to-Close
ØR	Air-to-Open

PED Compliance	
Ø	Not Required
F	CE Category 1
Z	Non-Standard

Consult factory for equal percentage requirements



Jordan Valve a division of Richards Industries
 3170 Wasson Road • Cincinnati, OH 45209
 513.533.5600 • 800.543.7311 • 513.871.0105 (f)
 info@richardsind.com • www.jordanvalve.com