

Y-Type Strainers

Line Strainers, with Threaded or Flanged Ends

Y-type line strainers protect your fluid handling system against the damage that can occur to valves, traps and other equipment when foreign matter such as dirt, scale or welding particles travel through the pipeline. Available with threaded or flanged end connections in Carbon Steel, Stainless Steel, Bronze or Cast Iron; for services up to 1480 psi.



Strainers feature a machine-tapered seat for a perfect fit of the removable strainer screen; and a blow-off plug that can be replaced with an optional ball valve for in-line blowdown of dirt, scale, etc. Selected sizes are in stock and ready for immediate delivery.

SERVICE CONSIDERATIONS

- For maximum protection, collected material must be discharged through the blow-off connection on a routine basis.
- A permanent blow-down line and ball valve with each strainer will result in simplified cleaning.
- Install horizontally or vertically with dirt collecting inside the screen.
- Screen can also be removed and cleaned with solvent and compressed air.
- Inspect the gasket and replace if necessary when replacing the screen.

SPECIFICATIONS

Body, Cover, Plug:

- Cast Iron: High tensile ASTM A126 Class B
- Bronze: ASTM B62 Bronze
- Carbon Steel: ASTM A216, Grade WCB
- Stainless Steel: ASTM A351, Grade CF8M

Screen: Stainless Steel, Monel optional

ENGINEERING DATA

Screen Mesh Size / Openings

Size	Standard Mesh	Opening
1/2" - 1-1/2"	0.033" perf	0.033"
2" - 3"	0.045" perf	0.045"
4" - 12"	0.125" perf	0.125"

Note: other mesh sizes available as an option; consult factory.

Operating Pressures & Temperatures

Flanged End Strainers, PSI @ °F				
Type	Size	Flange	Steam	W.O.G.
Y125CI	2" - 10"	125	125 @ 400°F	200 @ 150°F
Y250CI	2" - 10"	250	250 @ 450°F	500 @ 150°F
Y150CS	1/2" - 10"	150	200 @ 400°F	285 @ 100°F
Y150SS	1/2" - 10"	150	195 @ 400°F	275 @ 100°F

Operating Pressures & Temperatures

Threaded End Strainers, PSI @ °F			
Type	Size	Steam	W.O.G.
Y125BR	1/2" - 3"	125 @ 406°F	200 @ 150°F
Y250CI	1/2" - 3"	250 @ 406°F	400 @ 150°F
Y600CS	1/2" - 2"	825 @ 800°F	1480 @ 100°F
Y600SS	1/2" - 2"	790 @ 900°F	1440 @ 100°F



Jordan Valve, a division of Richards Industries
 3170 Wasson Road • Cincinnati, OH 45209
 513.533.5600 • 800.543.7311 • 513.871.0105 (f)
 info@richardsind.com • www.jordanvalve.com

ENGINEERING DATA

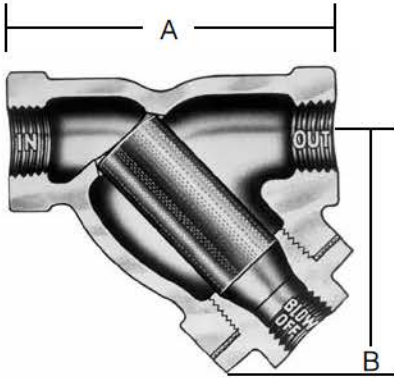

Size	A (in.)	B (in.)	Blow-off (in.)	Weight (lbs.)	Size	A (in.)	B (in.)	Blow-off (in.)	Weight (lbs.)
Threaded, Y125BR					Threaded, Y250CI				
1/2"	3.25	2.13	0.38	0.50	1/2"	3.19	2.06	0.25	1.50
3/4"	4.00	2.75	0.38	0.75	3/4"	3.75	2.44	0.38	2.50
1"	4.50	3.00	0.50	1.25	1"	4.00	2.44	0.38	3.00
1-1/4"	5.38	3.50	0.50	1.75	1-1/4"	5.00	3.38	0.75	5.50
1-1/2"	6.25	3.88	0.50	2.50	1-1/2"	5.75	3.88	0.75	8.00
2"	7.50	5.50	0.50	4.00	2"	7.00	4.75	1.00	13.00
2-1/2"	9.06	6.00	0.50	6.00	2-1/2"	9.25	5.88	1.00	22.00
3"	10.25	6.25	0.50	9.00	3"	10.00	6.00	1.00	30.00
Threaded, Y600CS or Y600SS					Flanged, Y125CI				
1/2"	2.91	2.25	0.25	2.00	2"	8.88	6.00	0.50	22.00
3/4"	3.44	2.56	0.38	3.00	2-1/2"	10.75	8.00	1.00	35.00
1"	4.56	2.81	0.38	5.00	3"	11.50	8.75	1.00	43.00
1-1/4"	4.94	3.06	0.75	7.00	4"	13.88	9.50	1.25	75.00
1-1/2"	5.56	3.31	0.75	10.00	6"	18.50	12.63	1.50	154.00
2"	6.94	4.81	1.00	15.00	8"	21.38	16.38	1.50	243.00
					10"	26.00	19.00	2.00	390.00
Flanged, Y250CI					Flanged, Y150CS or Y150SS				
2"	8.88	6.50	0.50	28.00	1/2"	6.00	3.88	0.25	5.50
2-1/2"	10.75	7.00	1.00	38.00	3/4"	7.00	4.25	0.38	6.50
3"	11.50	8.00	1.00	54.00	1"	7.50	4.75	0.50	9.00
4"	13.88	10.75	1.00	110.00	1-1/2"	9.00	5.63	0.50	12.00
6"	18.50	16.25	1.50	224.00	2"	8.63	5.25	0.50	20.00
8"	21.37	19.50	1.50	468.00	2-1/2"	10.25	7.50	0.75	32.00
10"	26.00	21.25	2.00	590.00	3"	11.63	7.69	1.00	36.00
					4"	14.38	9.13	1.50	61.00
					6"	18.63	13.00	2.00	160.00
					8"	24.38	15.32	2.00	210.00
					10"	26.00	19.13	2.00	440.00

ORDERING SCHEMATIC

1	2	3	4	5	6

1	Model	
Y	Y-Type Strainer	
2	Pressure Rating	
125	ANSI 125#; CI, BR	
150	ANSI 150#; BR, CS, SS	
250	ANSI 250; CI, BR	
300	ANSI 300#; CS, SS	
600	ANSI 600#; CS, SS	
3	Body Material	
CI	Cast Iron	
BR	Bronze	
CS	Carbon Steel	
SS	Stainless Steel	

4	Size					
2	1/2"	7	2"	C	5"	
3	3/4"	8	2-1/2"	D	6"	
4	1"	9	3"	E	8"	
5	1-1/4"	B	4"	F	10"	
6	1-1/2"					

5	Connection			
1	NPT	K	250# ANSI Flange	
2	SWE (CS/SS only)	4	300# ANSI Flange	
J	125# ANSI Flange	5	600# ANSI Flange	
3	150# ANSI Flange			

6	Screen Size		
0	Standard	Z	Non-Standard



Jordan Valve, a division of Richards Industries
 3170 Wasson Road • Cincinnati, OH 45209
 513.533.5600 • 800.543.7311 • 513.871.0105 (f)
 info@richardsind.com • www.jordanvalve.com