



FLANGELESS CHECK VALVE

MODEL CKF3MG/CKF3RG

HIGH QUALITY UNIQUE DISC TYPE CHECK VALVE BETWEEN FLANGES WITH CENTER GUIDED VALVE DISC

Benefits

All stainless steel, compact check valve for steam and water services.

1. Fine-machined metal or FPM-inlaid center-guided valve disc provides tight closure and durability.
2. Stainless steel body and internal parts ensure long service life.
3. Design provides for easy repair and maintenance.
4. Center-guided design offers the highest performance assurance for installation in either vertical or horizontal pipelines.
5. Unique body shape allows simple, perfectly concentric installation between flanges of all major flange standards without the use of measuring instruments.



Specifications

Model	CKF3MG	CKF3RG
Connection	Between Flanges	Between Flanges
Size (in)	2, 2½, 3, 4	2
Compatible Flange Standards	Shown on reverse	Shown on reverse
Sealing Surface*	Stainless Steel	Fluorine Rubber
Maximum Operating Pressure (psig) PMO	425	230
Minimum Opening Differential Pressure** (psi)	0.15	0.15
Minimum Required Differential Pressure for Tight Sealing (psi)	—	7.3
Maximum Operating Temperature (°F) TMO	662	302
Maximum Allowable Pressure (psig) PMA	425	425
Maximum Allowable Temperature (°F) TMA	662	662
Applicable Fluids***	Steam, Water	Air, Water

* Perfect sealing cannot be guaranteed for metal sealing surfaces.

Degradation of, or debris on, rubber sealing surfaces may also prevent perfect sealing.

** When the valve has remained closed for a long period of time, the valve and the valve seat may stick, increasing the necessary minimum opening differential pressure.

*** Do not use for toxic, flammable, or otherwise hazardous fluids

Connections and sizes in bold are standard



To avoid abnormal operation, accidents or serious injury, DO NOT use this product outside of the specification range. Local regulations may restrict the use of this product to below the conditions quoted.

No.	Description	Material	ASTM/AISI*	JIS
①	Body	Cast Stainless Steel	A351 Gr.CF8	—
②	Valve Disc	Cast Stainless Steel	A351 Gr.CF8	—
③	Coil Spring	Stainless Steel	AISI304	SUS304
④	Spring Holder	Stainless Steel	AISI304	SUS304
⑤	Nameplate	Stainless Steel	AISI304	SUS304
⑥	Valve Disc Inlay (CKF3RG)	Fluorine Rubber	D2000HK	FPM

* Equivalent

Replacement Parts are not available for this product as special equipment is required for assembly / disassembly.

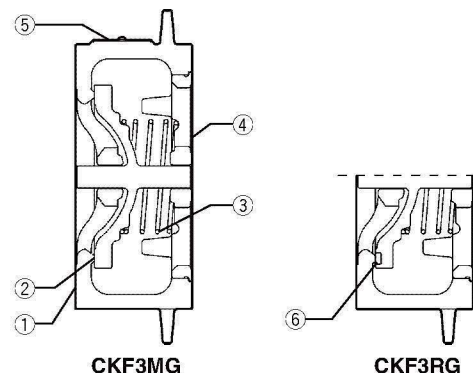

Copyright © TLV

Dimensions

• **CKF3MG/CKF3RG** Flangeless

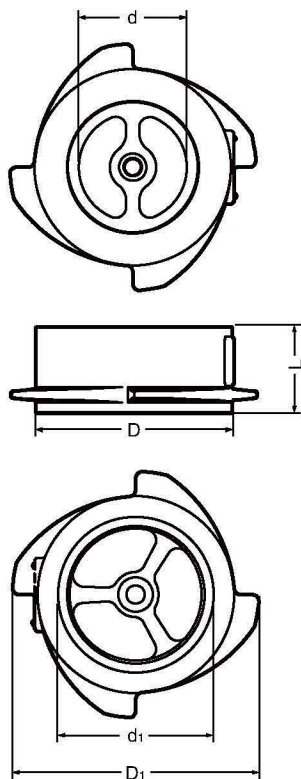

CKF3MG Flangeless (in)

Size	L	φ D	D ₁	φ d	φ d ₁	Weight (lb)
2	1 ⁹ / ₁₆	3 ⁹ / ₁₆	4 ¹ / ₂	2	2 ¹³ / ₁₆	2.2
2 ¹ / ₂	1 ¹³ / ₁₆	4 ⁹ / ₁₆	5 ⁹ / ₁₆	2 ⁹ / ₁₆	3 ⁷ / ₁₆	3.8
3	2	5 ³ / ₁₆	6	3 ¹ / ₈	4 ¹ / ₈	5.1
4	2 ³ / ₈	6 ³ / ₁₆	7 ⁵ / ₁₆	3 ¹⁵ / ₁₆	4 ⁷ / ₈	7.7

CKF3RG Flangeless (in)

Size	L	φ D	D ₁	φ d	φ d ₁	Weight (lb)
2	1 ⁹ / ₁₆	3 ⁹ / ₁₆	4 ¹ / ₂	2	2 ¹³ / ₁₆	2.2

Connectable Flange Standards

Size (in)	ASME, JPI	JIS	DIN	BS Table
2	Class 125, 150, 250, 300	5, 10, 16, 20, 30 K	PN 6, 10, 16, 25, 40	A, D, E, F, H, J
2 ¹ / ₂				F, H, J
3		10, 16, 20, 30 K	PN 10, 16, 25, 40	A, D, E, F, H, J
4				

Cv Values

Size (in)	2	2 ¹ / ₂	3	4
Cv (US)	54	100	140	240
Cv (UK)	45	83	117	200
Kvs (DIN)	46	85	120	206

CAUTION DO NOT DISASSEMBLE OR REMOVE THIS PRODUCT WHILE IT IS UNDER PRESSURE. Allow internal pressure of this product to equal atmospheric pressure and its surface to cool to room temperature before disassembling or removing. Failure to do so could cause burns or other injury. READ INSTRUCTION MANUAL CAREFULLY.

TLV CORPORATION

13901 South Lakes Drive, Charlotte, NC 28273-6790
 Phone: 704-597-9070 Fax: 704-583-1610
 E-mail: tlv@tlvengineering.com
 For Technical Service 1-800 "TLV TRAP"



Manufacturer
TLV CO., LTD.
 Kakogawa, Japan
 is approved by LRQA Ltd. to ISO 9001/14001

ISO 9001/ISO 14001

