

TLV[®]

RADIATOR TRAP

RT3A



Improved Performance – Less Maintenance

Easy Maintenance

All internal parts can be accessed by removing the trap cover.

Labor-Saving Design

A unique nipple is incorporated into the trap inlet to facilitate installation and removal of the trap with wrenches and channel-locks.

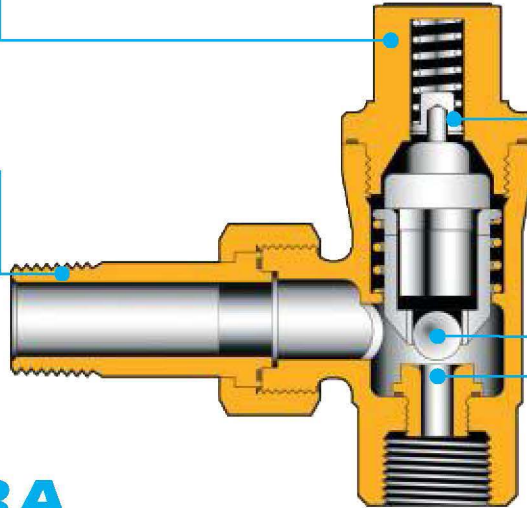

Overexpansion Protection

The thermo-element is protected from overexpansion by the overexpansion spring, providing stable performance and long life.

Durable Construction

No leakage through the trap orifice, due to the durability and smooth sealing of the ball valve.

Improved Valve Seat

A larger valve orifice permits more rapid purging of rust, scale and initial air, allowing faster warm-ups.

Radiator Trap RT3A

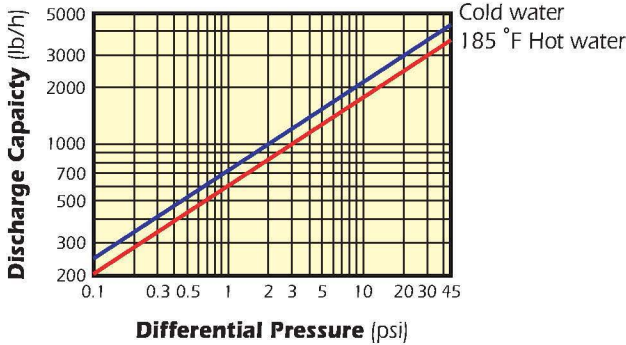

Body Material	Brass
Connection	Screwed
Size	1/2", 3/4"
Max. Operating Pressure	PMO 45 psig
Min. Operating Pressure	1.5 psig
Max. Operating Temperature	TMO 292 °F
Max. Allowable Pressure	PMA 45 psig
Max. Allowable Temperature	TMA 292 °F
Open-Close Temperature	approx. 203 °F – 212 °F



CAUTION

To avoid abnormal operation, accidents or serious injury, DO NOT use this product outside the specification range. Local regulations may restrict this product below the conditions quoted.

Operation

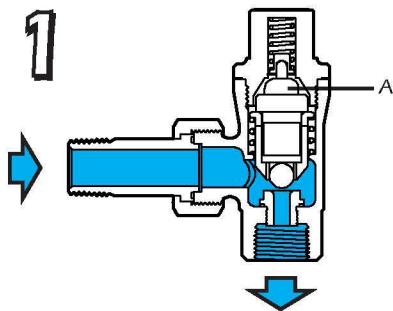

At low temperatures during start-up, the thermo-element (A) is fully retracted, keeping the valve fully open and allowing air and condensate to be discharged.

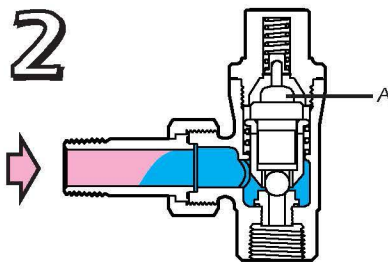

After discharging the initial condensate from start-up, as the condensate temperature raises past approx. 212 °F the thermo-element (A) expands and pushes the valve shut.

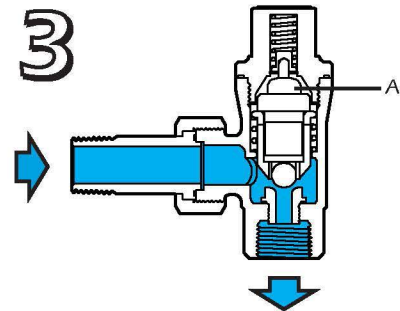

When the temperature of the condensate in the trap drops below approx. 203 °F, the thermo-element (A) retracts, discharging condensate. If the temperature rises above approx. 212 °F, the valve shuts again as in step 2.



DO NOT DISASSEMBLE OR REMOVE THIS PRODUCT WHILE IT IS UNDER PRESSURE. Allow internal pressure of this product to equal atmospheric pressure and its surface to cool to room temperature before disassembling or removing. Failure to do so could cause burns or other injury. READ INSTRUCTION MANUAL CAREFULLY.

TLV CORPORATION

13901 South Lakes Drive, Charlotte, NC 28273-6790

Phone: 704-597-9070 Fax: 704-583-1610

E-mail: tlv@tlvengineering.com

For Technical Service 1-800 "TLV TRAP"



Manufacturer

TLV CO., LTD.

Kakogawa, Japan

is approved by LRQA Ltd. to ISO 9001/14001

ISO 9001/ISO 14001

