



# FLANGELESS CHECK VALVE

## MODEL CKF3M/CKF3R

### HIGH QUALITY UNIQUE DISC TYPE CHECK VALVE BETWEEN FLANGES

#### Benefits

**Compact stainless steel check valve for steam, air and water services.**

1. Fine-machined metal or fluorine rubber valve seat provides tight closure.
2. Stainless steel body and internal parts ensure long service life.
3. Performance assured with installation in either horizontal or vertical pipelines.
4. Can be simply installed between all major flange types without measuring instruments, concentric due to its unique body shape.
5. Easy repair and maintenance possible.



#### Specifications

Model	CKF3M	CKF3R
Connection	<b>Between Flanges</b>	Between Flanges
Size (in)	<b>1/2, 3/4, 1, 1 1/4, 1 1/2</b>	1/2, 3/4, 1, 1 1/4, 1 1/2
Connectable Flange Standards	Shown on reverse	Shown on reverse
Sealing Surface*	Stainless Steel	Fluorine Rubber
Maximum Operating Pressure (psig) PMO	425	230
Minimum Opening Differential Pressure** (psi)	0.3	0.3
Minimum Required Differential Pressure for Tight Sealing (psi)	—	7.3
Maximum Operating Temperature (°F) TMO	662	302
Maximum Allowable Pressure (psig) PMA	425	425
Maximum Allowable Temperature (°F) TMA	662	662
Applicable Fluids***	Steam, Water	Air, Water

\* Perfect sealing cannot be guaranteed for metal sealing surfaces.

Degradation of, or debris on, rubber sealing surfaces may also prevent perfect sealing.

\*\* When the valve has remained closed for a long period of time, the valve and the valve seat may stick, increasing the necessary minimum opening differential pressure.

\*\*\* Do not use for toxic, flammable or otherwise hazardous fluids

**Connections and sizes in bold are standard**



To avoid abnormal operation, accidents or serious injury, DO NOT use this product outside of the specification range. Local regulations may restrict the use of this product to below the conditions quoted.

No.	Description	Material	ASTM/AISI*	JIS
①	Body	Cast Stainless Steel	A351 Gr.CF8	—
②	Valve Disc	Stainless Steel	AISI303	SUS303
③	Coil Spring	Stainless Steel	AISI304	SUS304
④	Spring Holder	Stainless Steel	AISI304	SUS304
⑤	Valve Disc Inlay (CKF3R)	Fluorine Rubber	D2000HK	FPM

\* Equivalent

Replacement Parts are not available for this product as special equipment is required for assembly / disassembly.

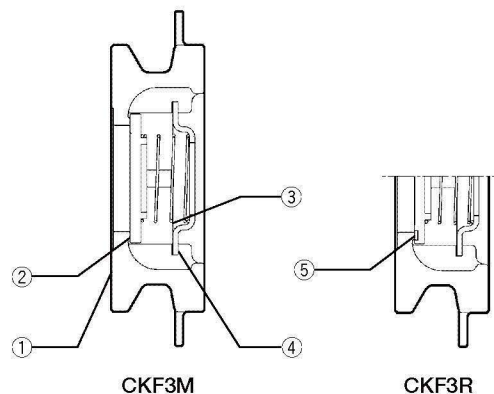

**Dimensions**

• **CKF3M/CKF3R** Flangeless

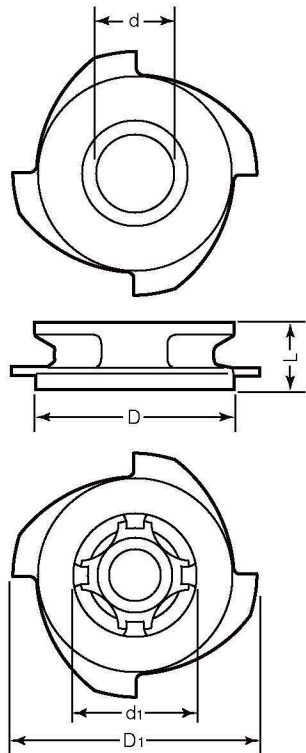

**CKF3M/CKF3R** Flangeless (in)

Size	L	φ D	D <sub>1</sub>	φ d	φ d <sub>1</sub>	Weight (lb)
1/2	5/8	1 11/16	2 1/2	9/16	1	0.31
3/4	3/4	2 1/16	2 11/16	13/16	1 5/16	0.49
1	7/8	2 1/2	3 1/8	1	1 9/16	0.73
1 1/4	1 1/8	2 7/8	3 1/2	1 1/4	1 7/8	1.12
1 1/2	1 1/4	3 3/16	3 15/16	1 9/16	2 1/4	1.37

**Connectable Flange Standards**

Size (in)	ASME, JPI	JIS	DIN	BS Table
1/2, 3/4	Class 150, 300	5, 10, 16, 20, 30 K	PN 6, 10, 16, 25, 40	A, D, E, F, H, J
1-1 1/2	Class 125, 150, 250, 300			

**Cv Values**

Size (in)	1/2	3/4	1	1 1/4	1 1/2
Cv (US)	4.6	8.8	16	20	29
Cv (UK)	3.8	7.3	13	17	24
Kvs (DIN)	3.9	7.5	14	17	25

**CAUTION** DO NOT DISASSEMBLE OR REMOVE THIS PRODUCT WHILE IT IS UNDER PRESSURE. Allow internal pressure of this product to equal atmospheric pressure and its surface to cool to room temperature before disassembling or removing. Failure to do so could cause burns or other injury. READ INSTRUCTION MANUAL CAREFULLY.

**TLV CORPORATION**

13901 South Lakes Drive, Charlotte, NC 28273-6790  
 Phone: 704-597-9070 Fax: 704-583-1610  
 E-mail: [tlv@tlvengineering.com](mailto:tlv@tlvengineering.com)  
 For Technical Service 1-800 "TLV TRAP"



Manufacturer  
**TLV CO., LTD.**  
 Kakogawa, Japan  
 is approved by LRQA Ltd. to ISO 9001/14001

ISO 9001/ISO 14001

