

WRA102 Standard High Precision Regulator

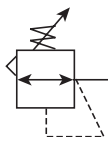

Features

- Control sensitivity of .125" (.32 cm) water column allows use in precision processes.
- Pressure balanced supply valve prevents supply pressure changes from affecting the setpoint.
- Optional check valve permits dumping of downstream pressure when supply is opened to atmosphere.
- Separate control chamber isolates the diaphragm from the main flow to eliminate hunting and buzzing.
- An aspirator tube compensates downstream pressure droop under flow conditions.

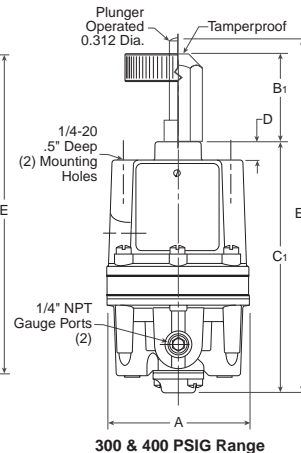
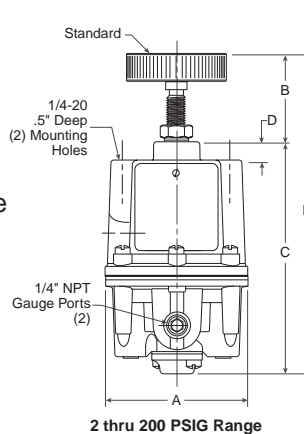

WRA102 Regulator Dimensions		
A 3.00 (76.2)	B 2.22 (56.5)	B₁ 2.13 (53.9)
C 4.42 (111.9)	C₁ 4.78 (121.6)	D 0.38 (9.4)
E 6.63 (168.5)	E₁ 7.28 (184.9)	

Inches (mm)

The WRA102 Regulator is designed for applications that require high capacity and accurate process control. A poppet valve which is balanced by utilizing a rolling diaphragm, insures a constant output pressure even during wide supply pressure variations. Stability of regulated pressure is maintained under varying flow conditions through the use of an aspirator tube which adjusts the air supply in accordance with the flow velocity.

⚠ WARNING

**Product rupture can cause serious injury.
 Do not connect regulator to bottled gas.
 Do not exceed maximum primary pressure rating.**

Ordering Information

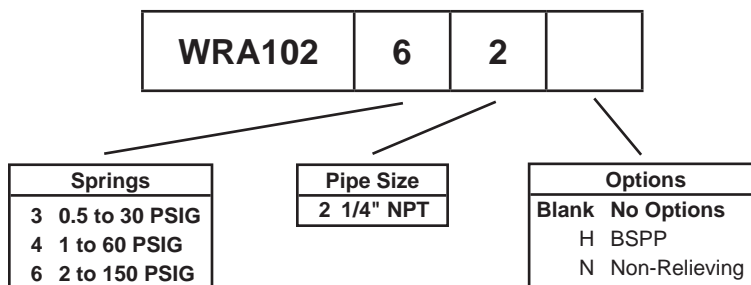

Note: Other Spring Ranges, Port Sizes, and Options Available.
 Please Consult Factory

BOLD ITEMS ARE MOST POPULAR.

Technical Information

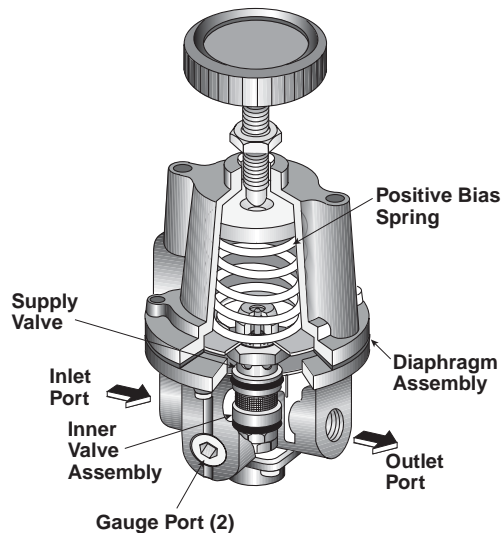
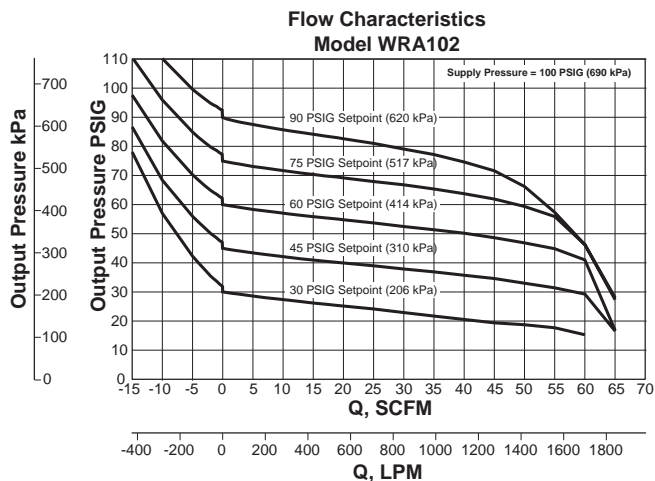

Operating Principles

The WRA102 Series regulator use the force balance principal to control the movement of the Valve Assembly that controls the output pressure. When the regulator is adjusted for a specific set point, the downward force of the Positive Bias Spring moves the Diaphragm Assembly downward. The Supply Valve opens and allows air to pass to the Outlet Port. As the set point is reached, the downward force exerted by the Positive Bias Spring is balanced by the force of the downstream pressure that acts on the Diaphragm Assembly. The resultant force moves the Supply Valve upward to reduce the flow of air to the Outlet Port.

Outlet pressure is maintained as a result of balance between forces acting on the top and bottom of the Diaphragm Assembly.

WRA102 Kits & Accessories

Mounting Bracket Kit –
 Zinc Plated Steel..... PS09921

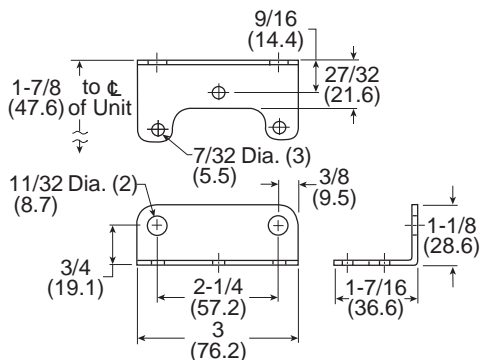

Service Kits
 0 to 200 PSIG, Relieving..... PS12125-1
 0 to 200 PSIG, Non-relieving PS12125-4
Tamper Resistant Kit..... PS12165

Specifications

Supply Pressure..... 500 PSIG, (35.0 bar), (3500 kPa) Maximum
Flow Capacity –
 40 SCFM (68 m³/HR) @ 100 PSIG, (7.0 bar), (700 kPa) Supply and 20 PSIG, (1.5 bar), (150 kPa) Setpoint
Exhaust Capacity –
 5.5 SCFM (9.35 m³/HR) where Downstream Pressure is 5 PSIG, (.35 bar), (35 kPa) above 20 PSIG, (1.5 bar), (150 kPa) Setpoint
Supply Pressure Effect –
 Less than 0.1 PSIG, (.007 bar), (.7 kPa) for 100 PSIG, (7.0 bar), (700 kPa) change in Supply Pressure
Sensitivity..... .125" (.005 PSIG) (.32 cm) Water Column
Ambient Temperature-40°F to +200°F, (-40°C to 93°C)
Hazardous Locations –
 Acceptable for use in Zones 1 and 2 for Gas Atmosphere:
 Groups IIA and IIB and Zones 21 and 22 for Dust Atmospheres

Materials of Construction

Body and Housing Aluminum
Diaphragms..... Buna N on Dacron (Standard Unit Only)
Trim.....Brass, Zinc Plated Steel