

Mark 695 Series

Piloted Tank Blanketing Regulator 3/4" - 1"

The Mark 695 Series piloted soft seat regulator was designed specifically to provide accurate pressure control on very low pressure tank blanketing systems. The pilot operated Mark 695 responds to very small changes in tank pressure by throttling open or closed to maintain the desired pressure set point.

- Accurate regulation down to 1/2" wc (1.25 mbar)
- ANSI Class VI Shutoff
- Two available spring ranges
- 200 psi maximum inlet pressure
- Five Cv's; 1, 2, 4, 7.5*, 10*
- Standard Filter with dripwell to prevent pilot damage
- Ultra Lightweight Diaphragm for Maximum Sensitivity

*7.5 Cv and 10 Cv available in 1" size only

OPTIONAL FEATURES

- Inlet Gauges: 0-100, 0-200
- Diagnostic Gauges: 0-100, 0-200
- Gauge Pair- Inlet & Diagnostic: 0-100, 0-200
- Purge Feature
- Optional High Alloys Available
- ANSI, DIN, & JIS Flanged Ends



*Shown with Optional Inlet Gauge

SPECIFICATIONS

Sizes: 3/4" - 1" (DN20 - DN25)

End Connections

- FNPT, ANSI Flanges — DIN, JIS

Body Materials

- Stainless Steel — ASTM A479 316SS
- Other Materials Available - Consult Factory

Trim Material: 316SS (Standard on all valves)

Main Valve Seat Material: 316SS/Viton, EPDM, Buna-N

Actuator Materials

- Stainless Steel

Diaphragm Material: Ultra Lightweight Teflon

Service: Tank blanketing

Shutoff: ANSI Class VI

Available Spring Ranges

- 0.5-5.5 wc, 4-10 wc

Minimum & Maximum Pressure Drop: 25 psi minimum (1,7 bar); 200 psi maximum (13,8 bar)

Pressure Temperature Ratings (Body):

Maximum inlet 200 psi @ 100°F

Maximum Outlet Casing Pressure: 25 psi (1,7 bar)

Flow Coefficients:

- 1, 2, 4, 7.5*, 10* Cv

Set Point	Maximum Inlet Pressure (Consult Factory for Higher Inlet Pressures)
	3/4" - 1" Size
0.50" - 0.70" w.c. (1.24- 1.8 mbarg) (Please consult the factory)	100 psig (6.9 barg)
0.75" - 1.00" w.c. (1.9- 2.5 mbarg)	125 psig (8.6 barg)
1.05" - 10" w.c. (2.6-34.5 mbarg)	200 psig (13.8 barg)
Inlet Pressure	
Minimum	20 psig (1.38 barg)
Recommended	≥ 35 psig (2.41 barg)

* 1" only

FLOW TABLE FOR NITROGEN

				C _v 1		C _v 2		C _v 4		C _v 7.5*		C _v 10*	
psig	bar	kg/cm ³	kPa	SCFH	Nm ³ /h	SCFH	Nm ³ /h	SCFH	Nm ³ /h	SCFH	Nm ³ /h	SCFH	Nm ³ /h
25	1.7	1.76	172	1,404	39.8	3,120	88.4	5,024	142	9,256	262	11,001	312
30	2.1	2.11	207	1,584	44.9	3,521	99.7	5,670	161	10,446	296	12,416	352
40	2.8	2.81	276	1,940	55.0	4,312	122	6,944	197	12,791	362	15,203	431
50	3.4	3.52	345	2,276	64.4	5,057	143	8,278	234	15,540	440	20,144	570
60	4.1	4.22	414	2,628	74.4	5,839	165	9,558	271	17,943	508	23,258	659
70	4.8	4.92	483	2,979	84.4	6,621	188	10,837	307	20,345	576	26,372	747
80	5.5	5.62	552	3,304	93.6	7,342	208	11,537	327	22,747	644	29,486	835
90	6.2	6.33	621	3,856	109	8,569	243	13,466	381	25,149	712	32,600	923
100	6.9	7.03	689	4,225	120	9,388	266	14,753	418	27,551	780	35,713	1011
110	7.6	7.73	758	4,593	130	10,206	289	16,039	454	29,953	848	38,827	1100
120	8.3	8.44	827	4,961	141	11,025	312	17,325	491	32,356	916	41,941	1188
130	9.0	9.14	896	5,329	151	11,843	335	18,611	527	34,758	984	45,055	1276
140	9.7	9.84	965	5,698	161	12,662	359	19,898	564	37,160	1052	48,168	1364
150	10.3	10.55	1034	6,066	172	13,480	382	21,184	600	39,562	1120	51,282	1452
160	11.0	11.25	1103	6,435	182	14,299	405	22,470	636	41,964	1188	54,396	1540
170	11.7	11.95	1172	6,803	193	15,118	428	23,756	673	44,366	1256	57,510	1629
180	12.4	12.66	1241	7,171	203	15,936	451	25,043	709	46,768	1324	60,624	1717
190	13.1	13.36	1310	7,540	214	16,755	475	26,329	746	49,171	1393	63,737	1805
200	13.8	14.06	1379	7,908	224	17,573	498	27,615	782	51,573	1461	66,851	1893

* Please refer to API 2000 for calculation of flow requirements.

Conversion Factors:

- Air- Multiply by 0.985
- Dry CO₂- Multiply by 0.797
- Natural Gas (sg 0.60)- Multiply by 1.270

For all other gasses, compute a correction factor which is equal to 0.985/(√SG). Then multiply by the correction factor.

* 7.5 Cv and 10 Cv available in 1" size only

PRINCIPLE OF OPERATION

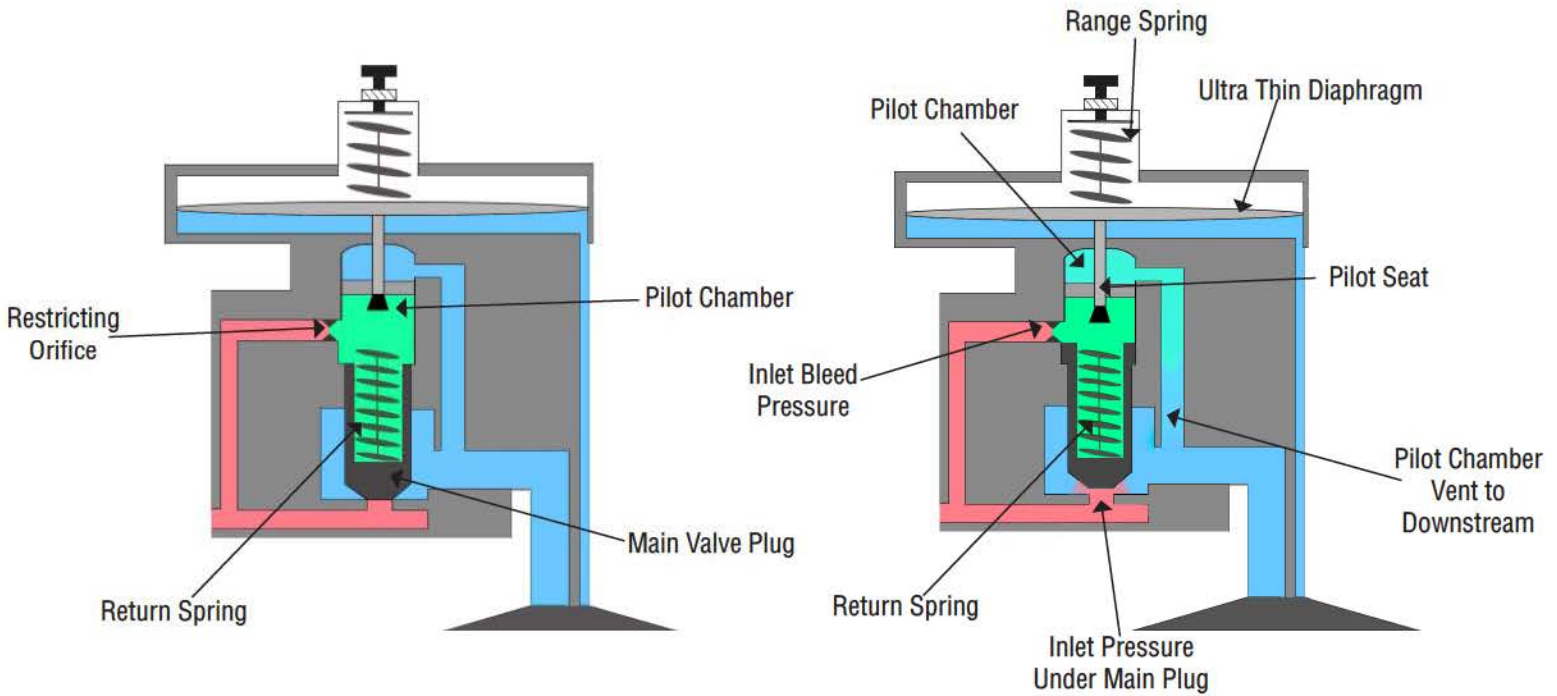

Figure 1 - Valve Closed

Inlet pressure is under the main valve plug, and through the restricting orifice it is also in the pilot chamber, and above the main valve plug, Inlet pressure above the main valve plug, together with the return spring hold the plug down and closed.

Inlet Pressure
Control Pressure
Tank Pressure

Figure 2 - Valve Open

As the pressure in the tank falls, the reduced pressure force on the ultra thin diaphragm allows the range spring to push down against the pilot and open the pilot seat. Pressure from the pilot chamber and above the main valve plug begins to vent to downstream. Inlet bleed pressure is unable to be replenished in the pilot chamber and above the main valve plug because of the restricting orifice and this allows the unrestricted inlet pressure below the main valve plug to open it against the return spring.

MARK 695 SERIES PILOTED TANK BLANKETING REGULATOR

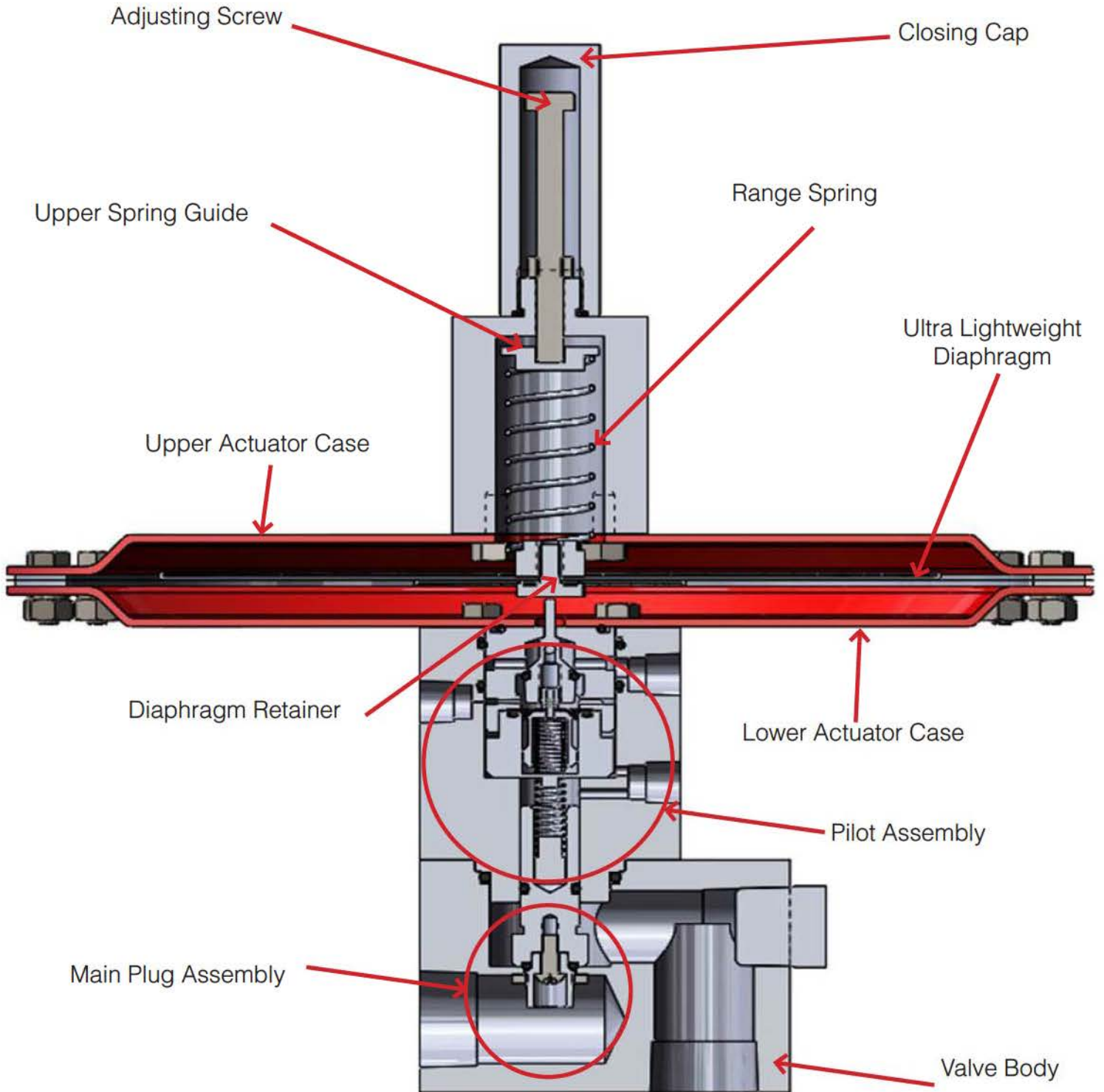

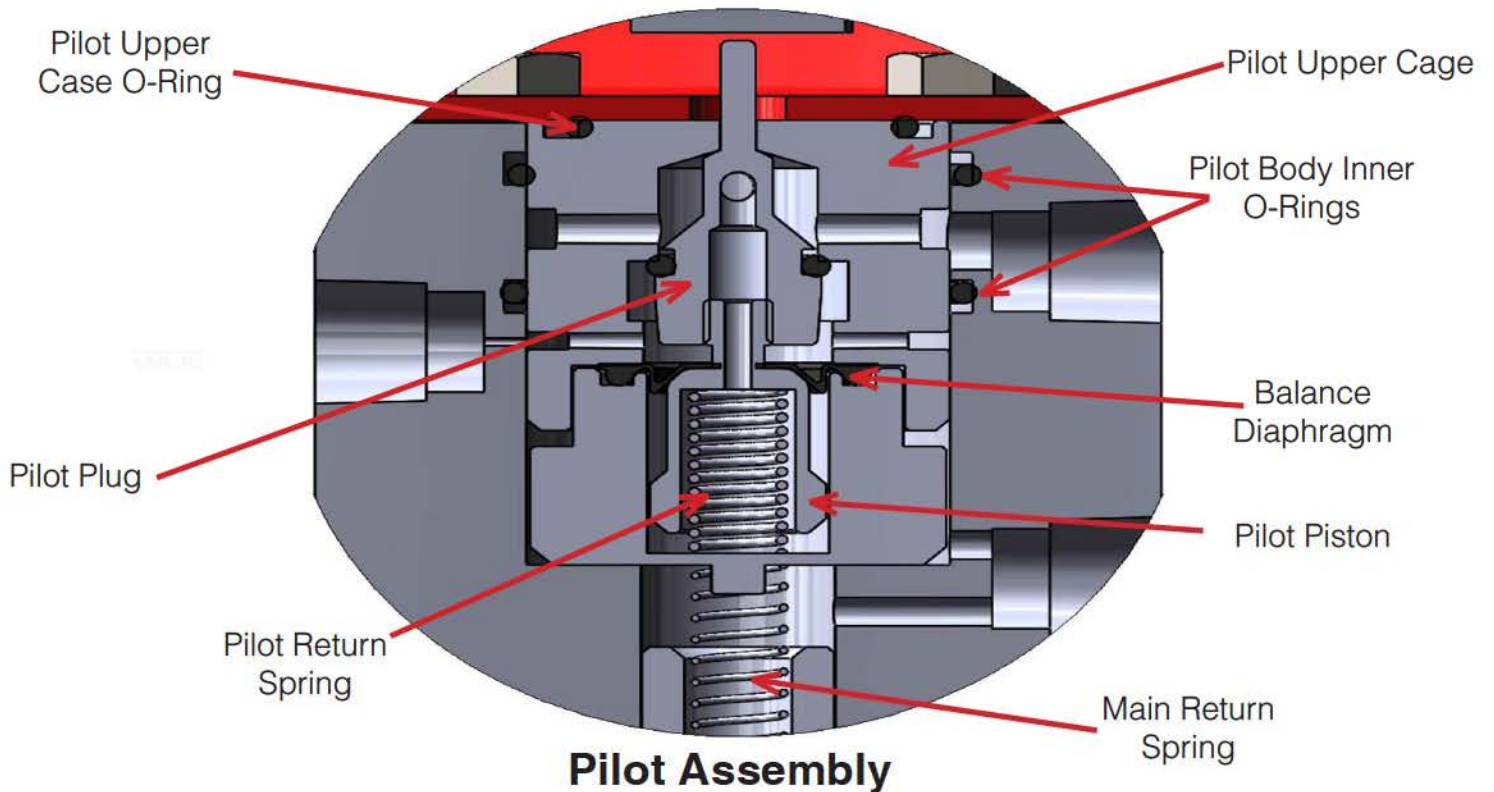
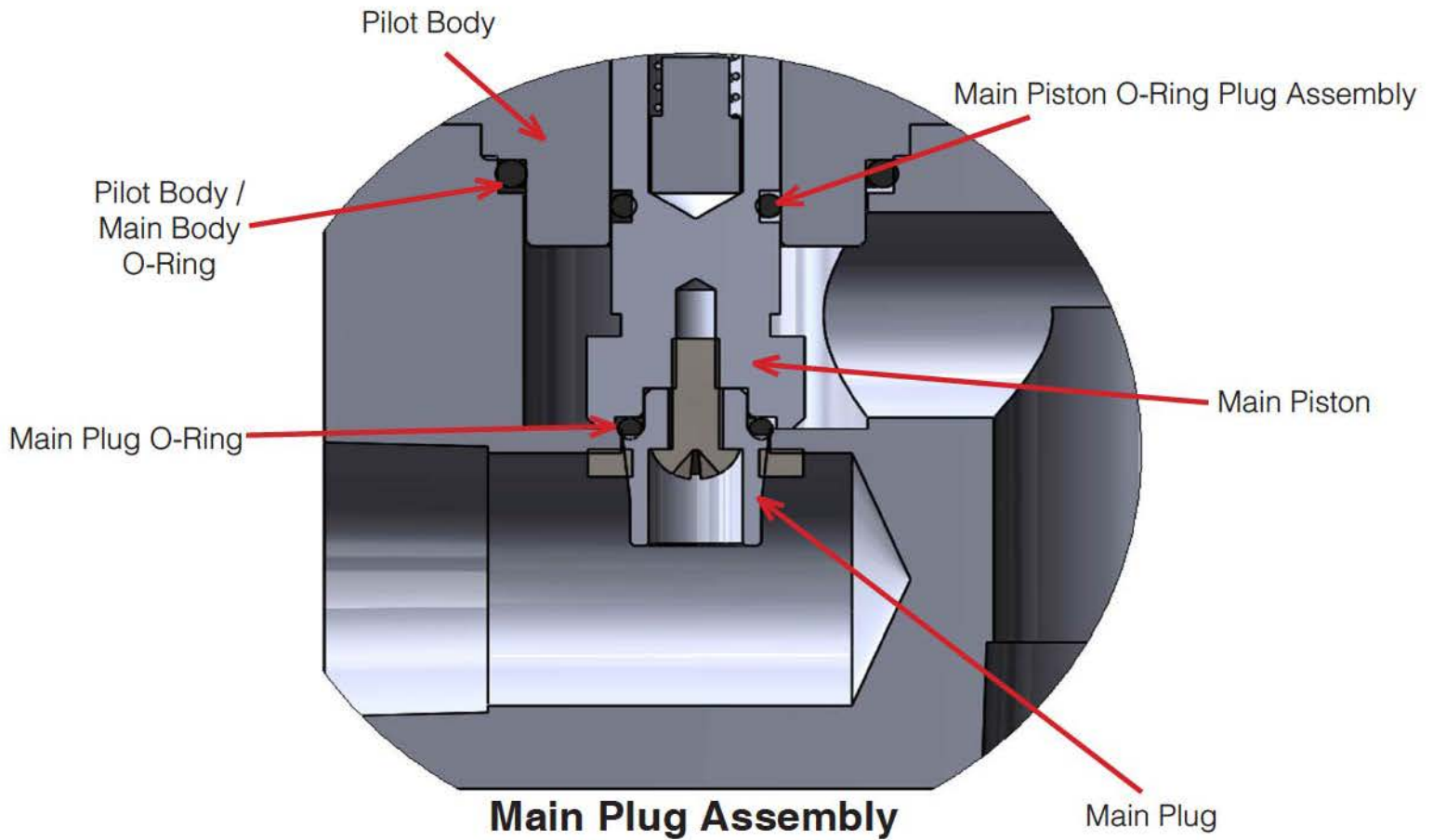

DIMENSIONS

3/4" - 1" MK695

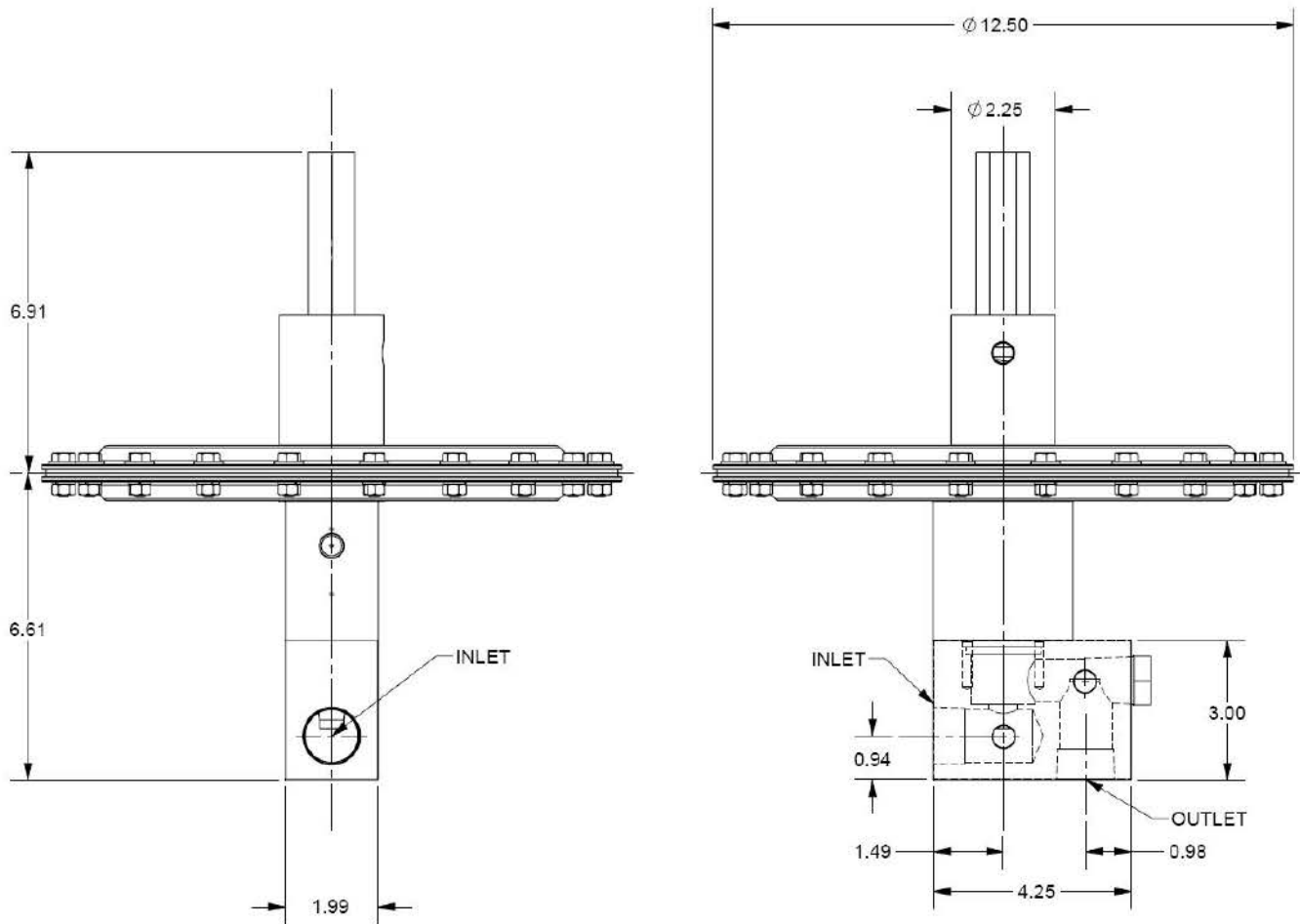

MK695 Tank Blanketing Regulator
FNPT Ends as Shown, Other End Connections available, Consult Factory

ORDERING SCHEMATIC FOR MK695

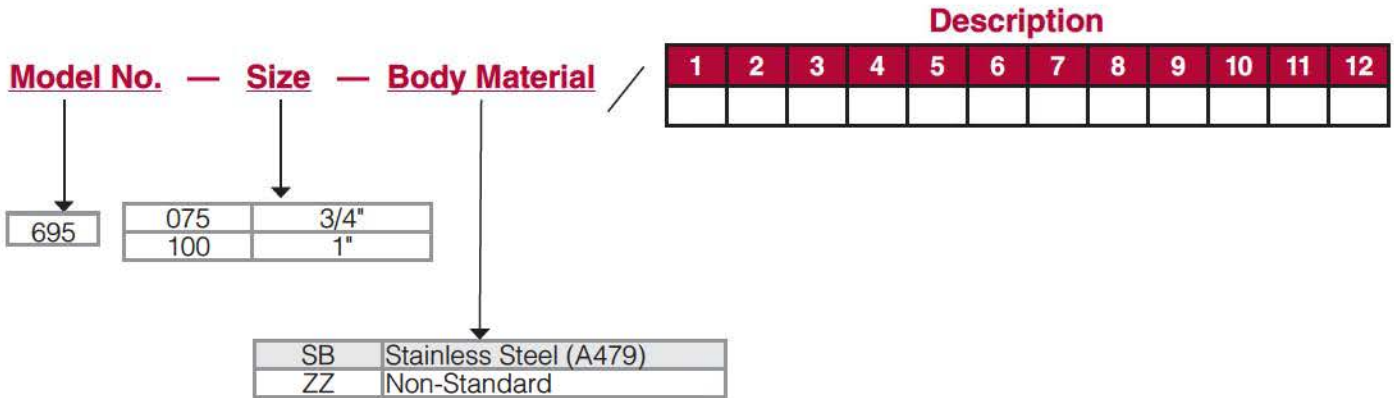

1 & 2 End Conn. & Cv			
P	NPT	A	1-2
		B	4
		C	7.5
		D	10
ZZ	Non- Standard		

7 & 8 Range	
A7	0.5 - 5.5" w.c.
A8	4-10" w.c.
ZZ	Non-Standard

3 & 4 Seat & O- Ring			
B	Buna-N	A	1-2
V	Viton	B	4
E	EPDM	C	7.5
		D	10

9 & 10 Actuator	
S1	Standard
ZZ	Non-Standard

5 & 6 Cv	
A1	1 Cv
A2	2 Cv
A4	4 Cv
A7*	7.5 Cv
A9*	10 Cv

11 & 12 Accessory	
G1	Inlet Gauge 0-100
G2	Inlet Gauge 0-200
D1	Diagnostic GA. 0-100
D2	Diagnostic GA. 0-200
11	Inlet/ Diag. Pair 0-100
22	Inlet/ Diag. Pair 0-200
P1	Purge System
ZZ	Non-Standard

* Available in 1" size only

CAUTION: The following information is subject to change. Product Numbers and Description should be checked with the Factory for accuracy before Order Entry.



Jordan Valve a division of Richards Industries
 3170 Wasson Road • Cincinnati, OH 45209
 513.533.5600 • 800.543.7311 • 513.871.0105 (f)
 info@richardsind.com • www.jordanvalve.com