

WRA171 High Precision Vacuum Regulator

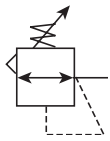

Features

- Control sensitivity of .125" (.32 cm) water column allows use in precision applications.
- Balanced supply valve minimizes effects of vacuum variation.
- Aspirator tube compensates for downstream pressure droop under flow conditions.
- Separate control chamber isolates the diaphragm from the main flow to eliminate hunting and buzzing.
- Construction allows servicing without removing from the line.

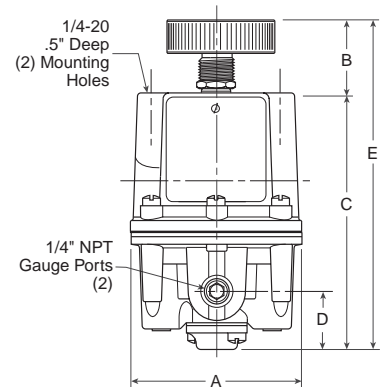

WRA171 Regulator Dimensions		
A	B	C
3.00 (76.2)	1.13 (28.7)	4.83 (122.6)
D	E	
1.00 (25.4)	5.96 (151.3)	

Inches (mm)

The WRA171 is a high accuracy vacuum regulator that provides uniform vacuum regulation independent of vacuum supply changes and flow demand.

This unit has a diaphragm assembly with three springs to provide a more balanced loading of the diaphragm.

⚠ WARNING
Product rupture can cause serious injury. Do not connect regulator to bottled gas. Do not exceed maximum primary pressure rating.

Ordering Information

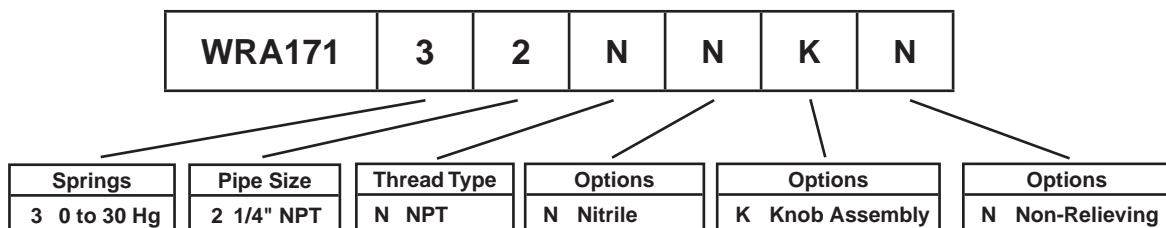

Note: Other Spring Ranges, Port Sizes, and Options Available.
 Please Consult Factory

BOLD ITEMS ARE MOST POPULAR.

Technical Information

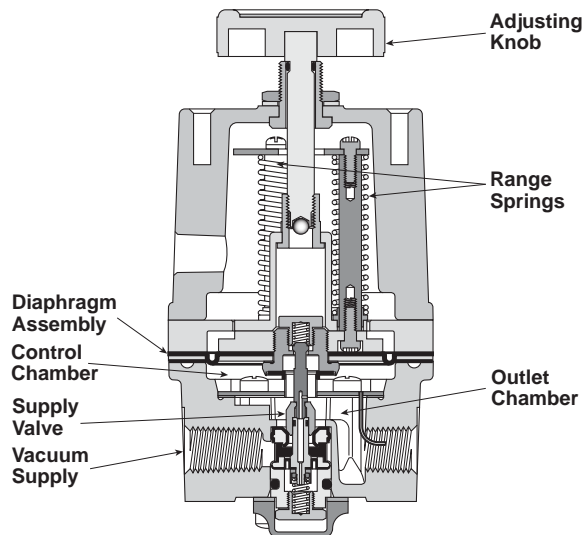
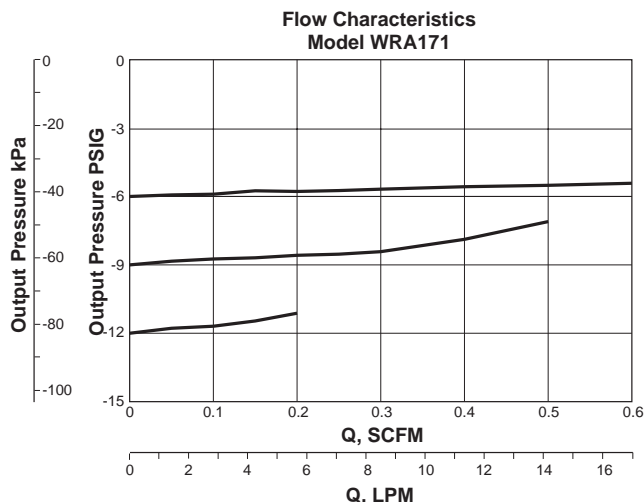

Operating Principles

The Model WRA171 Series vacuum regulator uses the force balance principle to control the movement of the Valve Assembly that controls output vacuum.

When the regulator is adjusted for a specific set point, the upward force of the Range Springs moves the Diaphragm Assembly upward. The Supply Valve opens and allows air to pass to the inlet port. As the set point is reached, the upward force exerted by the Range Springs is balanced by the force of the vacuum that pulls downward on the Diaphragm Assembly. The resultant force moves the Supply Valve downward to reduce the flow of air to the inlet port. Outlet vacuum is maintained as a result of balance between forces acting on the top and bottom of the Diaphragm Assembly.

WRA171 Kits and Accessories

Mounting Bracket PS09921

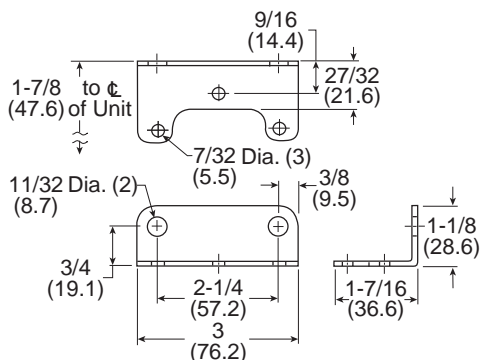

Service Kits

(Includes Diaphragm Assy, Valve Assy, Seat Assy & Gasket) –
 0-30" Hg, Nitrile, Nonrelieving PS20966-9
 Tamper Resistant Kit PS20967-1

Specifications

Vacuum Supply (Max) 29.92 Hg (760 torr)
 Flow Capacity 3 SCFM @ 650 torr Supply, 250 torr Setpoint
 Sensitivity125" (.005 PSIG) (.32 cm) Water Column
 Ambient Temperature -40°F to +200°F, (-40°C to +93°C)
 Vacuum Supply Effect –
 Less than 1 torr for 100 torr (.04 Hg for 3.94 Hg) Change in
 Vacuum Supply

Materials of Construction

Body and Housing Aluminum
 Trim Zinc Plated Steel, Brass
 Elastomers Nitrile