



# FREE FLOAT<sup>®</sup> STEAM TRAP

## MODEL JH8R-X/JH8R-B

### FREE FLOAT STEAM TRAP WITH THERMOSTATIC AIR VENTING

#### Benefits

**A reliable and durable cast steel steam trap for use on large-size process equipment. JH8R-B is also suitable for high-pressure process equipment**

1. Self-modulating free float provides continuous, smooth, low-velocity condensate discharge as process loads vary.
2. Constant water seal design ensures a steam-tight seal, even under low-load conditions.
3. Only one moving part, the free float, eliminates concentrated valve wear and provides long maintenance-free service life.
4. Rugged float construction with up to 1500 or 1600 psig\* hydraulic shock rating ensures excellent resistance of the float to water hammer.
5. **JH8R-X**: Thermostatic capsule (X-element) with "fail open" feature vents air automatically at close-to-steam temperature.
6. **JH8R-B**: Thermostatic bimetal air vent valve vents air automatically for rapid startup.
7. Built-in screen with large surface area ensures extended trouble-free operation.

\* Depending on orifice No.



U.S. Pat. 5833135

#### Specifications

Model		JH8R-X	JH8R-B
Connection		<b>Flanged</b>	<b>Flanged</b>
Size (in)		<b>2, 3</b>	<b>2, 3</b>
Orifice No.		2, 5, 10, 14, 22, 32	40, 46
Maximum Operating Pressure (psig)	PMO	30, 75, 150, 200, 315, 450	600, 650
Maximum Differential Pressure (psi)	ΔPMX	30, 75, 150, 200, 315, 450	600, 650
Minimum Operating Pressure (psig)		Vacuum	1.5
Maximum Operating Temperature (°F)	TMO	464	800
Maximum Allowable Pressure (psig)	PMA	650	650
Maximum Allowable Temperature (°F)	TMA	800	800
Type of Air Vent		X-element (11 °F subcooling)	Bimetal (vents air up to approx. 212 °F)

Connections and sizes in bold are standard

No.	Description	Material	ASTM/AISI*	JIS	
①	Body	Cast Steel	A216 Gr.WCB	—	
②	Cover	Carbon Steel	A105	—	
③ <sup>F</sup>	Float	Stainless Steel	AISI316L	SUS316L	
④ <sup>R</sup>	Orifice	—	—	—	
⑤ <sup>MR</sup>	Orifice Gasket	Soft Iron	AISI1010	SUYP	
⑥ <sup>MR</sup>	Outlet Cover Gasket	Graphite/Stainless Steel	—/AISI304	—/SUS304	
⑦ <sup>R</sup>	Screen	Stainless Steel	AISI430	SUS430	
⑧	Screen Holder	Stainless Steel	AISI304	SUS304	
⑨	Snap Ring	Stainless Steel	AISI304	SUS304	
⑩ <sup>MR</sup>	Cover Gasket	Graphite/Stainless Steel	—/AISI304	—/SUS304	
⑪	Cover Bolt	Alloy Steel	A193 Gr.B16	SNB16	
⑫	Cover Nut	Carbon Steel	AISI1045	S45C	
⑬	Outlet Cover	Stainless Steel	AISI420	SUS420J2	
⑭	Outlet Cover Bolt	Alloy Steel	A193 Gr.B16	SNB16	
⑮	Outlet Cover Nut	Carbon Steel	AISI1045	S45C	
⑯ <sup>X</sup>	X-element Air Vent Unit	JH8R-X	—	—	
⑯ <sup>R</sup>	Bimetal Air Vent Unit	JH8R-B	—	—	
⑰ <sup>MRX</sup>	Air Vent Unit Gasket	Soft Iron	AISI1010	SUYP	
⑱ <sup>R</sup>	Air Vent Guide	JH8R-B	Stainless Steel	AISI303	SUS303
⑲	Nameplate	Stainless Steel	AISI304	SUS304	
⑳	Screen Holder Retainer	Stainless Steel	AISI304	SUS304	
㉑	Eye Bolt	Stainless Steel	A6	SS400	
㉒	Flange	Cast Steel	A216 Gr.WCB	—	
㉓ <sup>MR</sup>	Drain Plug Gasket	Soft Iron	AISI1010	SUYP	
㉔	Drain Plug	Carbon Steel	AISI1025	S25C	

\* Equivalent

Replacement kits available: (M) maintenance parts, (R) repair parts, (F) float, (X) X-element unit



To avoid abnormal operation, accidents or serious injury, DO NOT use this product outside of the specification range. Local regulations may restrict the use of this product to below the conditions quoted.

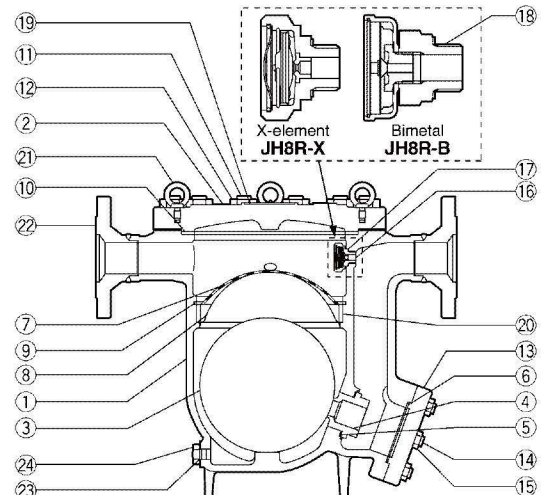

**Dimensions**

● JH8R-X/JH8R-B Flanged

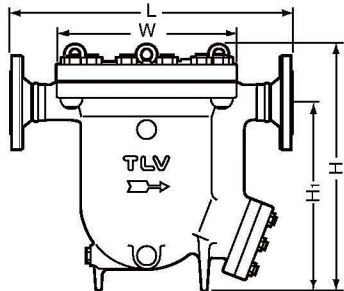

JH8R-X/JH8R-B Flanged (in)

Size	L			H	H <sub>1</sub>	φW	Weight* (lb)
	Connects to ASME Class						
	150RF	300RF	<b>600RF</b>				
2	23 1/4	23 1/2	24 1/4	20 5/8	15 3/4	14 3/4	265
3	23 1/8	23 9/16	24 5/16				287

Other standards available, but length and weight may vary

\* Weight is for Class 600 RF

Flange classes in bold are standard

**Discharge Capacity**

● JH8R-X

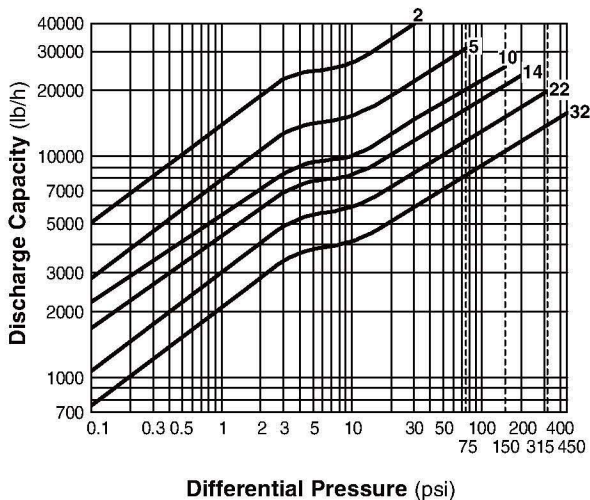

● JH8R-B

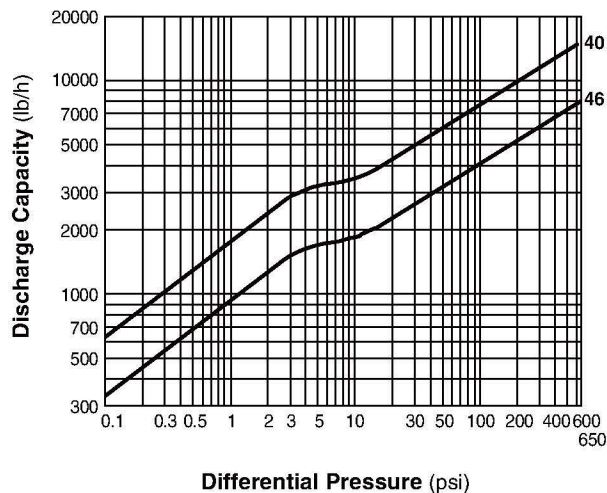

1. Line numbers within the graph are orifice numbers.
2. Differential pressure is the difference between the inlet and outlet pressure of the trap.
3. Capacities are based on continuous discharge of condensate 11°F below saturated temperature.
4. Recommended safety factor: at least 1.5.



Do not use traps under conditions that exceed maximum differential pressure, as condensate backup will occur!



DO NOT DISASSEMBLE OR REMOVE THIS PRODUCT WHILE IT IS UNDER PRESSURE. Allow internal pressure of this product to equal atmospheric pressure and its surface to cool to room temperature before disassembling or removing. Failure to do so could cause burns or other injury. READ INSTRUCTION MANUAL CAREFULLY.

**TLV CORPORATION**

13901 South Lakes Drive, Charlotte, NC 28273-6790  
 Phone: 704-597-9070 Fax: 704-583-1610  
 E-mail: [tlv@tlvengineering.com](mailto:tlv@tlvengineering.com)  
 For Technical Service 1-800 "TLV TRAP"



Manufacturer  
**TLV CO., LTD.**  
 Kakogawa, Japan  
 is approved by LRQA Ltd. to ISO 9001/14001

ISO 9001/ISO 14001

