

TLV[®]

PowerDyne[®]

Thermodynamic Steam Traps

P Series
FP Series
HR Series

Pure Performance

For Steam Mains and Tracers



Are you looking for Improved Performance?

Disc traps are valued for their compact size and wide pressure range, and are often chosen as an affordable product for condensate discharge.

But have you ever wondered how to...

... minimize chattering?

Disc traps can be susceptible to dirt, environmental conditions and no-load actuation, causing chattering which accelerates wear and shortens service life.

... improve steam sealing performance?

In order to prevent air binding, some valve discs have a rough-ground surface or machined leakage path. These actions reduce sealing and increase steam loss, and can eventually lead to a costly blowing condition.

... shorten start-up time?

Disc traps can air bind, which prolongs start-up time by preventing the discharge of condensate.

... reduce maintenance costs?

When disc traps fail, a common practice is to replace the entire trap, not just the internals. Short service life results in high replacement and maintenance costs.

PowerDyne®

Superior quality and reliability can minimize

Disc traps are highly versatile, yet typical models can be prone to air binding, short service life, and costly steam loss.

TLV has resolved these drawbacks with the **PowerDyne™ Series**, available in a full pressure range from near atmosphere up to supercritical pressure (3700 psig).

Air Jacketing

In traps with a single-layer cap, adverse weather conditions and radiant heat loss can result in steam loss from rapid-cycling actuation. The TLV PowerDyne series is equipped with an air-insulated jacket, giving resistance to environmental effects and minimizing unnecessary operation and steam loss.



Effect of Weather

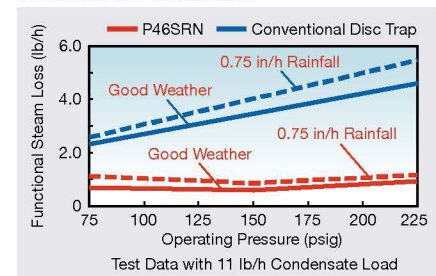

Mirror-polished Sealing Surfaces

Some valve discs include an air leak pathway or rough finish to prevent air binding. However, this can result in greater surface wear and steam leakage due to no-load actuation. The TLV PowerDyne series solves this problem: the bimetal air vent ring* eliminates air binding and allows the hardened sealing surfaces to be mirror-polished, resulting in a tight seal that saves steam.

* All models except HR150A, HR260A (due to superheat temperature limits), P46S, P21S ver.C

Comparing Cycling Rates

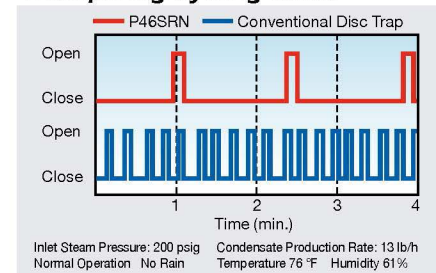

Bimetal Air Vent Ring

To reach full operating efficiency, initial air and cold condensate must be purged from steam lines quickly. PowerDyne's bimetal air vent ring* quickly and efficiently vents start-up air without binding, eliminating the need for manual blowdown.

* All models except HR150A, HR260A (due to superheat temperature limits), P46S, P21S ver.C

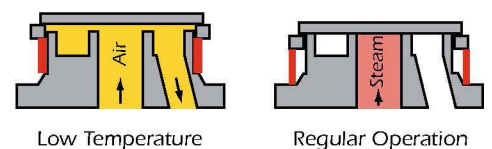

Replaceable Module

The replaceable module* facilitates inline replacement of normal wear parts, such as the valve disc and valve seat.

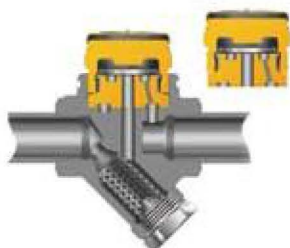

P Series

For pressures up to 925 psig
* All models except P46S, P21S ver.C

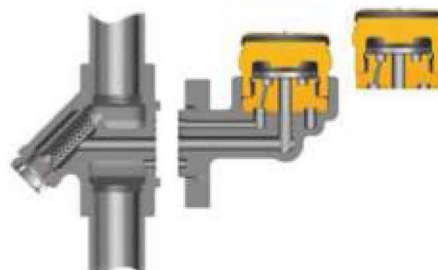

FP Series

With 2-bolt universal flange
For pressures up to 650 psig

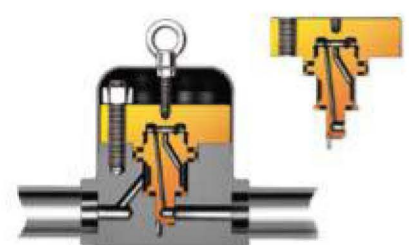

HR Series

For pressures up to 3700 psig



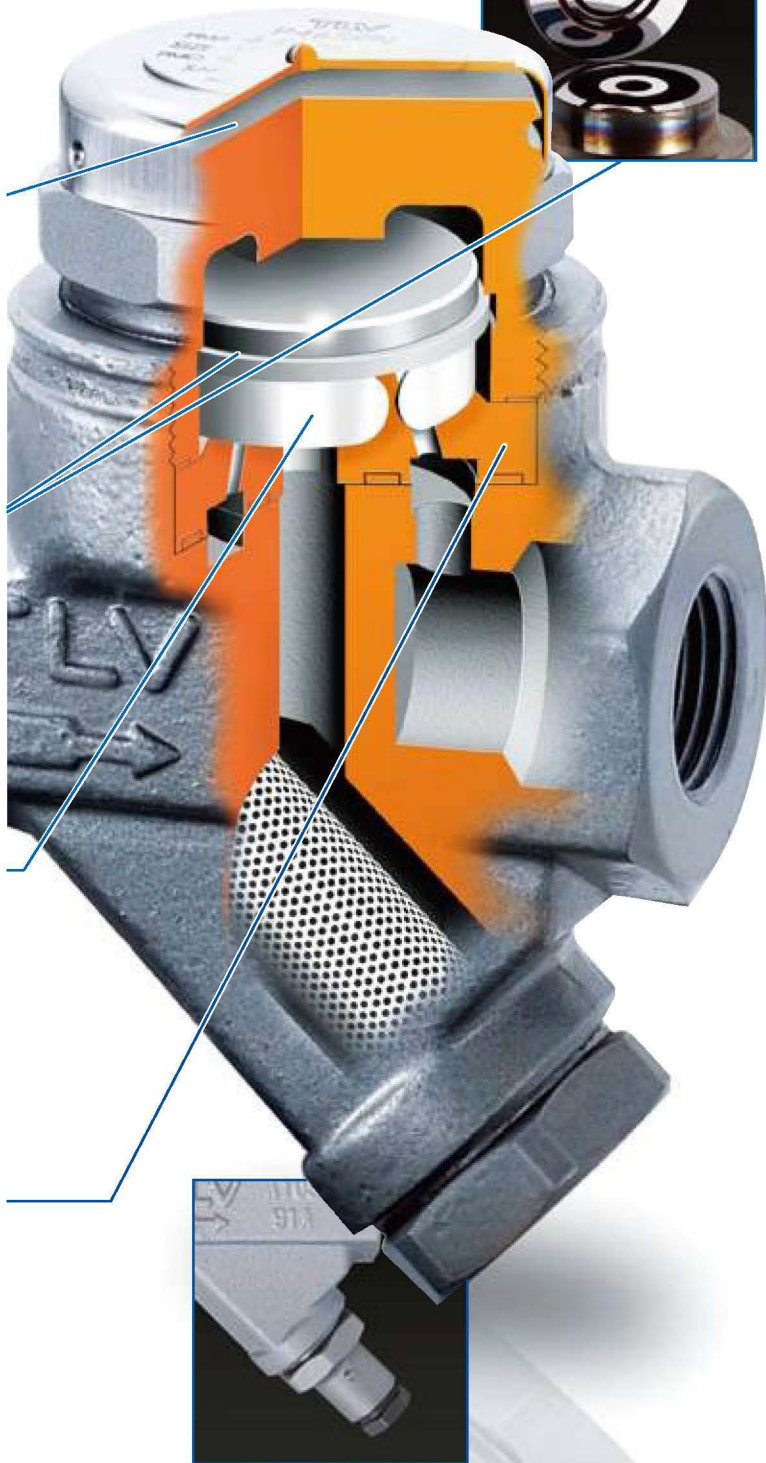

nize Life Cycle Cost

Mirror-polished Sealing Surfaces



With optional Blowdown Valve

How they operate

	Cold condensate		Air
	Hot condensate		Steam

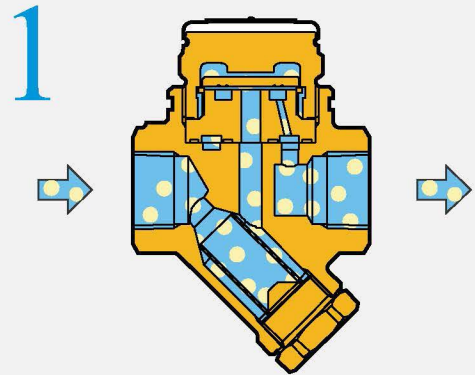

At start-up, the bimetal air vent ring is contracted, lifting the disc off the valve seat and allowing rapid discharge of air and cold condensate.

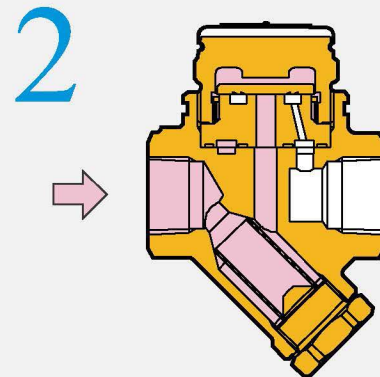

As temperature in the trap rises, the bimetal expands and releases the disc. The disc is forced downward by the low-pressure area created by the rapid flow of flashing condensate/steam below the disc, and the simultaneous high pressure in the pressure chamber above it. An air jacket insulates the cap's pressure chamber from the radiant heat loss that could cause no-load actuation.

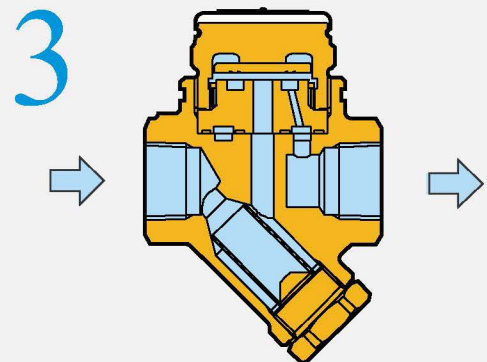

Eventually, as condensate enters the trap and the steam pressure in the pressure chamber lowers, the inlet pressure pushes the disc up and enables the discharge of condensate. Entering flashing condensate/steam then closes the trap, as in step 2.

Redefining the Disc Trap Concept

PowerDyne®

Life Cycle Cost for steam trap management includes multiple factors such as:

- Purchasing
- Installation
- Maintenance
- Steam loss

Minimize Disc Trap Life Cycle Cost by

1 Long Service Life

Air jacketing for resistance to environmental conditions, and hardened valve trim to reduce wear and promote reliable operation.

2 Energy Conservation

The mirror-polished, lapped disc provides tight sealing even under severe superheat conditions, effectively minimizing steam loss.

3 Increased Productivity

Initial Air is automatically discharged by the thermostatic air venting design*, significantly reducing start-up time.

* All models except HR150A, HR260A (due to superheat temperature limits), P46S, P21S ver.C

4 Easy Maintenance







The replacement module design* enables quick inline repair of normal wear parts, reducing maintenance costs.

* All models except P46S, P21S ver.C



PowerDyne® Series Lineup

up to 3700 psig

Model (Connection)	Appearance (Construction)	Operating Pressure Range (psig)	Max. Operating Temperature (°F)	Body Material	Max. Discharge Capacity (lb/h)	Air Jacketing	Thermostatic Air Venting	Replaceable Module	Built-in Screen	Blowdown Valve (Option)
Compact trap design includes built-in Y-strainer P21S ver.C is designed for use in copper tracing applications										
P21S ver.C (S) ¹⁾		3.5(6) - 300 (6): Vertical Installation	800	Cast Stainless Steel	850	●			●	● (BD1)
P46S (S) ¹⁾		5 - 650 ²⁾			1040					
Wide range of pressure and discharge capacities										
P46SRN (S,W) ¹⁾		5 - 650	800	Stainless Steel ³⁾ or Carbon Steel	1630	●	●	●	●	● (BD2)
P46SRM (S,W,F) ¹⁾					2980					
P46SRW (S,W) ¹⁾					5490					
P65SRN (S,W) ¹⁾					1030					
QuickTrap® Universal flange allows easy inline trap unit replacement										
FP46UC (S,W,F) ¹⁾		5 - 650	750	Stainless Steel	1630	●	●	●	●	● (BD2)
P46UC-Y (UF) ⁴⁾										
Ideal for use on high-temperature/high-pressure steam mains										
HR80A (W,F) ¹⁾		115 - 1150	887	Cro-Mo Alloy Steel	410	●	●	●	●	
HR150A (W,F) ¹⁾		230 - 2100	1022		480					
HR260A (W) ¹⁾		230 - 3700			505					

¹⁾ Letters in brackets show pipe connections available: S = screwed, W = socket weld, F = flanged.

²⁾ For best performance over extended periods, it is recommended that the trap be operated at or below 300 psig.

³⁾ Except for flanged models. ⁴⁾ UF = universal flange. P46UC-Y is designed for use with connector units that do not include a screen.

Full product details (sizes, pressures, capacities and materials) are included in the individual specification data sheets (SDS).



To avoid abnormal operation, accidents or serious injury, DO NOT use this product outside of the specification range. Local regulations may restrict the use of this product to below the conditions quoted.



DO NOT DISASSEMBLE OR REMOVE THIS PRODUCT WHILE IT IS UNDER PRESSURE. Allow internal pressure of this product to equal atmospheric pressure and its surface to cool to room temperature before disassembling or removing. Failure to do so could cause burns or other injury. READ INSTRUCTION MANUAL CAREFULLY.

TLV CORPORATION

13901 South Lakes Drive, Charlotte, NC 28273-6790

Tel: 704-597-9070 Fax: 704-583-1610

E-mail: tlv@tlvengineering.com <http://www.tlv.com>

For Technical Service 1-800 "TLV TRAP"



Manufacturer
TLV CO., LTD.
 Kakogawa, Japan
 is approved by LRQA Ltd. to ISO 9001/14001

