

Mark 4150 & 4160 Series

Pressure Controllers

Jordan Valve offers two types of Pressure Controllers:

- Proportional (Mark 4150)
- Proportional Reset (Mark 4160)

The Mark 4150 and 4160 Series are pneumatic pressure controllers that utilize a bourdon tube or bellows for sensing vapor, liquid or gas pressure, and differential pressure. The Jordan Valve controller can be re-configured from direct, to reverse acting or vice versa without any additional parts.

Jordan Valve Pressure Controllers offer dependability, toughness, sturdy construction, reliable performance, and accurate service. With regular scheduled maintenance, the pressure controller will provide continuous service for many years.

The Mark 4150 and Mark 4160 Pressure Controller is a weatherproof unit, and can be either mounted on the yoke of a control valve, wall mounted or panel mounted.



Mark 4150



Mark 4150



Mark 4160



Jordan Valve, a division of Richards Industries
 3170 Wasson Road • Cincinnati, OH 45209
 513.533.5600 • 800.543.7311 • 513.871.0105 (f)
 info@richardsind.com • www.jordanvalve.com

SPECIFICATIONS

Supply: Air or Natural Gas*

*natural gas should contain no more than 20ppm of Hydrogen Sulphide

Supply and Output Connections: 1/4" NPT Female

Supply Pressure:

- Normal operating pressure for 3 to 15 psig (0,2 to 1,0 bar) output signal range is 20 psig
- Normal operating pressure for 6 to 30 psig (0,4 to 2,0 bar) output signal range is 35 psig

Operating Temperature Limits: -40°F to 200°F (-40°C to 93°C)*

*Standard Construction

Operating Temperature Influence:

-Proportional Control:

Output pressure changes ± 3% of sensing element range for each 50°F (28°C) change in temperature between -40°F and +160°F (-40°C and +71°C) if the controller is set at 100% proportional band

-Reset Control:

Output pressure changes ± 2% of sensing element range for each 50°F (28°C) change in temperature between -40°F and +160°F (-40°C and +71°C) if the controller is set at 100% proportional band

Performance:

-Repeatability: 0.5% of sensing element range

-Deadband: 0.1% of output span

-Frequency response at 100% proportional band:
Output to actuator: 0.7 Hz and 110° phase shift with 113 inches³ (1850 cm³) volume, actuator at mid stroke

Output to positioner bellows: 9 Hz and 130° phase shift with 3 -15 psig (0.2 to 1.0 bar) output to 2 inches³ (33cm³) bellows

Output Signal: 3 to 15 psig (0,2 to 1,0 bar) or 6 to 30 psig (0,4 to 2,0 bar) pneumatic pressure signal

Action: The control action is easily reversible from **direct acting** (increasing sensed pressure produces increasing output signal) to **reverse acting** (increasing sensed pressure produces decreasing output signal) without the need for additional parts

Proportional Band Adjustment: Full output pressure change is adjustable from 3 to 100% for a 3 to 15 psig (0,2 to 1,0 bar), or 6 to 100% for a 6 to 30 psig (0,4 to 2,0 bar) of the sensing element range

Reset Adjustment: Adjustable from 0.01 to 74 minutes per repeat (100 to 0.01 repeats per minute)

DIMENSIONS

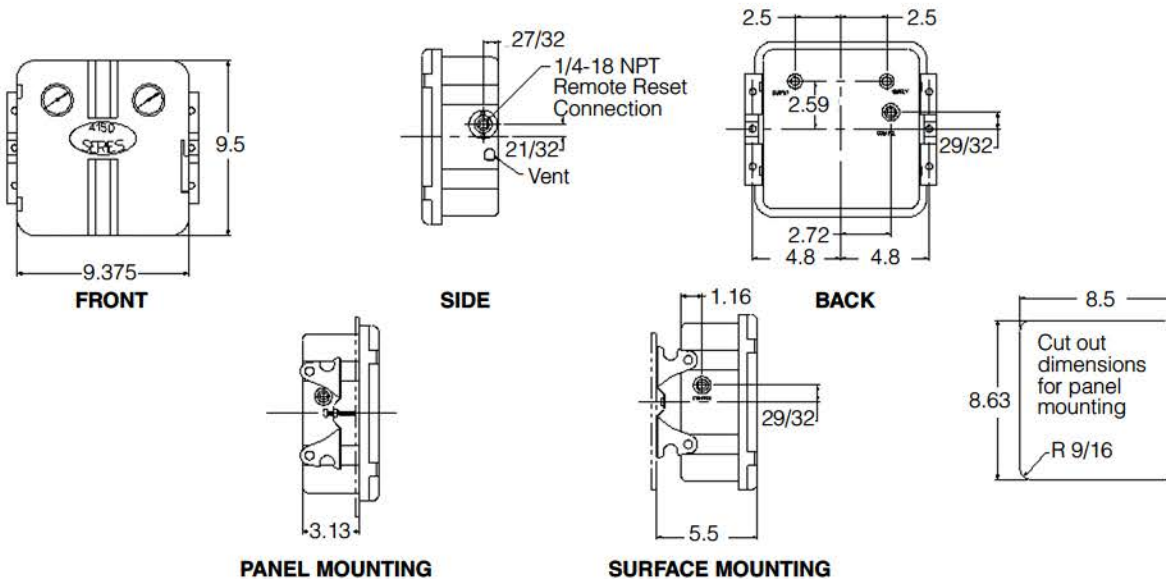

SUPPLY PRESSURE DATA

Output Signal Range		Normal Operating Supply Pressure (*)		Maximum Allowable Supply Pressure to Prevent Internal Damage		Steady State Air Consumption SCFH of Air at 60°F and 14.7PSIA (Normal M3/Hr of Air at 0°C and 1,01 Bar)	
Psig	Bar	Psig	Bar	Psig	Bar	Min ^A	Max ^B
3 to 15 or 0 & 20 (on-off)	0,2 to 1,0 or 0 & 20 (on-off)	20	1,4	50	3,4	4.2 (0.12)	27 (0,76)
6 to 30 or 0 & 30 (on-off)	0,4 to 2,0 or 0 & 2,4 (on-off)	35	2,4	50	3,4	7 (0.20)	42 (1,2)

* Stability and control may be compromised if pressure is exceeded; A Proportional Band setting of 0-10; B Proportional Band setting of 5