

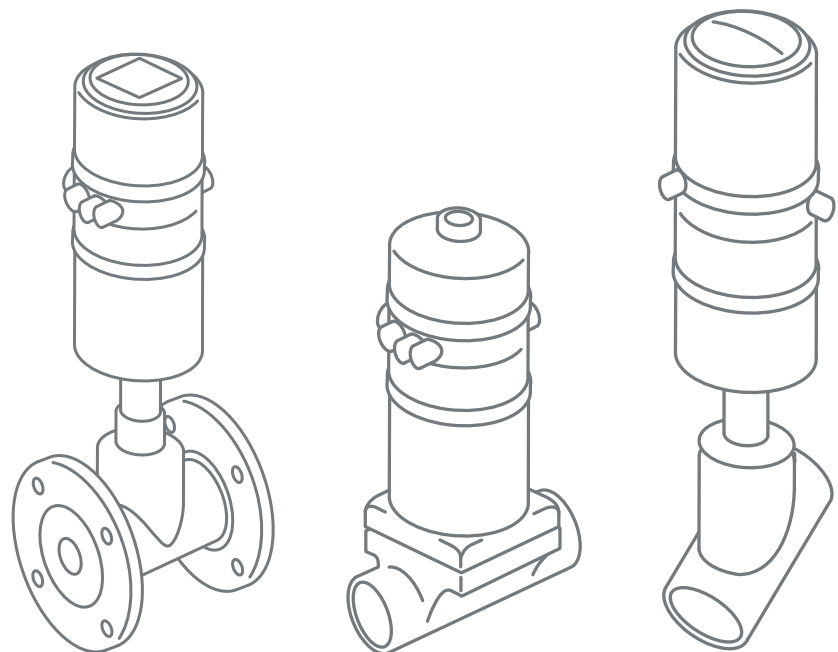

**bürkert**  
FLUID CONTROL SYSTEMS

# ELEMENT

## On/Off and Control Valves



## ELEMENT Intelligent, Integrated and Beautiful

ELEMENT is the new concept from Bürkert combining controllers, valves and sensors in a highly aesthetic stainless steel design together with an intelligent architecture. ELEMENT sensors and valves reliably control fluids, gases, steam, aggressive media or contaminated fluids.

ELEMENT process valves were developed for the decentralized automation of pneumatically acting process valves. This is achieved via the optimal integration of all automation functions in the pneumatic actuator in different variants. Innovative solutions insure due to experience in critical process environments robust and reliable systems.

The construction of the intelligent ELEMENT field devices fulfil in a unique way the demands of the hygienic process technique for cleaning, selection of material and high IP protection and compactness.

Give your plant a competitive edge. The new ELEMENTs of success.

- 3 Introduction
- 4 Beauty and the Beast
- 6 Actuation On/Off
- 8 Positioner & Process Controller
- 10 Compatibility Advantages
- 12 Innovative Functions Integrated
- 14 Intelligent Control Valve Systems
- 16 Sensors and Transmitters
- 18 Contacts at Bürkert

# Beauty



- Consistent and high class look for your equipment
- Intuitive /automatic programming
- Coloured high power LED showing the valve status
- Graphic backlit display for easy operation
- Various combination possibilities to meet the customers needs. Valves, controllers and sensors from Bürkert in a consistent design
- Designed according to EHEDG guidelines for materials compatibility, smooth surfaces and external seals

- IP65/IP67 practice-oriented and consistent reliable IP protection
- Easy and robust interface to combine all automation functions of the ELEMENT program
- Over pressure as an additional protection of the control heads against ingress of humidity and condensate accumulation
- Durability against cleaning agents
- Compressed air recycling prevents the surrounding atmosphere from the actuator chambers
- High life cycle of the valves, maximum availability of your plant
- Outstanding controllability with unlimited compactness
- Digital positioner or process controller with automated parametrization for positioner and process controller
- Security coded

# Beast

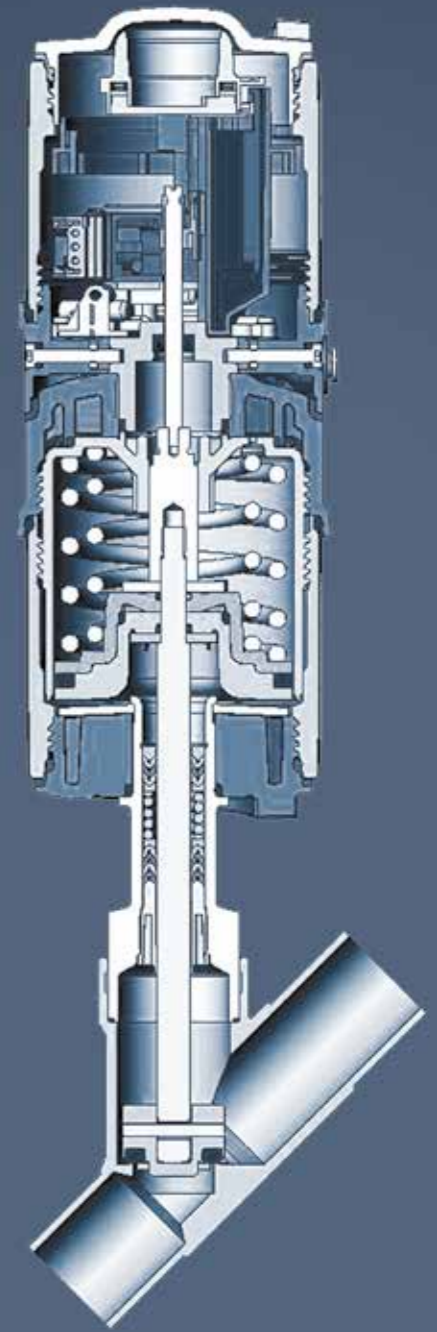



## Actuation On/Off

### Mechanical

- Optimised for cleaning and use in wet areas of hygienic processing plants
- Designed according to EHEDG guidelines for materials compatibility, smooth surfaces and external seals
- Optical on the site status indicators via coloured high power LEDs
- End position detection via micro switch, 3- / 2- wire initiator to wear-free working, analogue, inductive sensor with teach function
- Intergrated pilot valves with manual operation
- Control air filter protects from raw pollution
- Over pressure valve
- Electrical connection via plug-in connector M12 stainless steel or cable gland
- ATEX Zone 2/22 (optional) and Zone 1

### Communication

- AS-interface
- DeviceNET

### Automation concept

- Robust and practice-oriented solution for decentralized automation concepts
- Automation functions can be integrated modularly in the pneumatic actuator
- Minimalization of the electrical wiring and pneumatic piping
- Manual actuation and status indication in the field

### Set up

- Extremely compact integrated actuation to pneumatic actuator
- Internal control air routing without external wiring
- Control air supply to drive chambers by compressed air recycling
- Over pressure as additional protection against condensation in the actuators
- Can be also combined with the CLASSIC actuators 2000, 2012, 2031

### Look and Feel

- Exceptional



## Control heads for the integrated mounting on process valves

## On/Off valves



**Type 8690**



**Type 8697**

*Pneumatic control unit including pilot valve and mechanical or inductive limit switches*



**Type 8691**



**Type 8695**

*Control head with integrated pilot valve, teachable, contact free position feedback sensor and coloured high-power LED for status indication, communication via AS-interface and DeviceNet*



**Type 2000**  
*2/2-way angle-seat valve, DN 13-65, pneumatically operated, gunmetal or stainless steel body.*



**Type 2100**  
*2/2-way angle-seat valve with ELEMENT design, DN 13-50.*



**Type 2012**  
*2/2-way globe valve, pneumatically operated, stainless steel body, DN 10-100.*



**Type 2101**  
*2/2-way globe valve with ELEMENT design, DN 10-50.*



**Type 2031**  
*2/2-way diaphragm valve pneumatically operated, stainless steel body, DN 4-100.*



**Type 2103**  
*2/2-way diaphragm valve with ELEMENT design, DN 4-50.*



**Type 8692**  
Positioner



**Type 8693**  
Process controller



**Type 8694**  
Positioner BASIC



**Type 8696**  
Positioner BASIC for Bürkert's 50 mm actuator.



**Type 2300**  
2/2-way globe control valve with ELEMENT design, DN 13-65.



**Type 2301**  
2/2-way globe control valve with ELEMENT design, DN 4-100.



**Type 2103**  
2/2-way diaphragm valve with ELEMENT design, DN 4-50.

## Positioner & Process Controller

### Mechanical

- Optimised for the cleaning and use in wet areas of hygienic processing plants
- Designed according to EHEDG guidelines for sleek profile, material compatibility, smooth surfaces and external seals
- Contactless and wear -free position sensor
- Initiator as end position indicator
- Positioner BASIC for simple control loops
- Control air filter protects from raw pollution
- over pressure valve
- Electrical connection via plug-in connector M12 stainless steel oder cable gland
- ATEX Zone 2/22 (optional)
- Extremely compact integrated actuation to pneumatic actuator
- Internal control air routing without external wiring
- Compressed air recycling

### Communication

- Profibus DPV1
- DeviceNET
- AS-interface

### Set up

- Intelligent digital process controller mit automated X-tune
- Process Controller mit automated control loop detection and parameter optimising P-tune function
- Backlit graphic display
- Binary input and 2 binary outputs
- Analogue feedback of position respectively process setpoint or position respectively actual value
- Combination with Classic control valve actuators 2702,2712 and 2731

### Look and Feel

- Exceptional



## Compatibility Advantages

### ELEMENT actuators

Due to their hygienic design the new ELEMENT actuators have been optimized for the process control in the areas of food & beverage, dairy, brewery, cosmetics and pharma. The product range allows an easy and robust integration of actuators, positioners and process controllers while offering at the same time reliable and long-lasting IP-protection for the use in wet and high humidity areas.

### Classic actuators

The modularity allows the combination of the new On/Off Control Heads and positioners respectively process controller on our robust and worldwide proven CLASSIC actuators. Therewith the advantages of decentralized automation are used also here in a optimum way.

### Want more flexibility?

The program can also be combined with other actuators of other models and valve principles. It allows a decentralized automation concept for different pneumatic components.

Step 3: Pilot/Communicate



Step 2: Operate



Step 1: Choose your valve style





## Innovative Functions Integrated

The ELEMENT range of control heads, positioners and process controllers offer technical innovations which effect functional reliability and lifetime of the connected actuators - this helps you to save effort, time and costs. With a maximum of flexibility for planning and installation and minimal effort for commissioning and maintenance.

### Housing protected by over pressure

In the housing of types 8690 and 8691 a slight overpressure is controlled via the integrated air venting valve to prevent ingress of water and accumulation of condensate. Possibly negative pressure by cold washdown is avoided. Creation and collection of condensate is prevented.

### Integrated air inlet filter

An easy to service stainless steel mesh filter protects against the infiltration of bigger particles after the plant installation und during the normal service. Functional safety and lifetime of the actuator and the actuation are optimised.

### Integrated pilot valve

Proven Bürkert pilot valves with outstanding life time are used. Equipped with a manual actuation the in field operation of the process valve system is easy to handle. It enables the internal control air routing with compressed air recycling of the actuator.

### Compressed air recycling

By internal control air supply via the integrated pilot valve both chambers of the pneumatic actuator are charged with control air. With every power stroke- open and close- control flushes from the air vent of the actuation. In no case ambient atmosphere is drawn in the spring chamber.

This means:

- no corrosion of the actuator springs
- no contamination or humidity inside the actuator
- from the actuator chambers no humidity gets inside positioner and actuation
- no contamination of the plant environment by possible biological growth in the actuation chamber

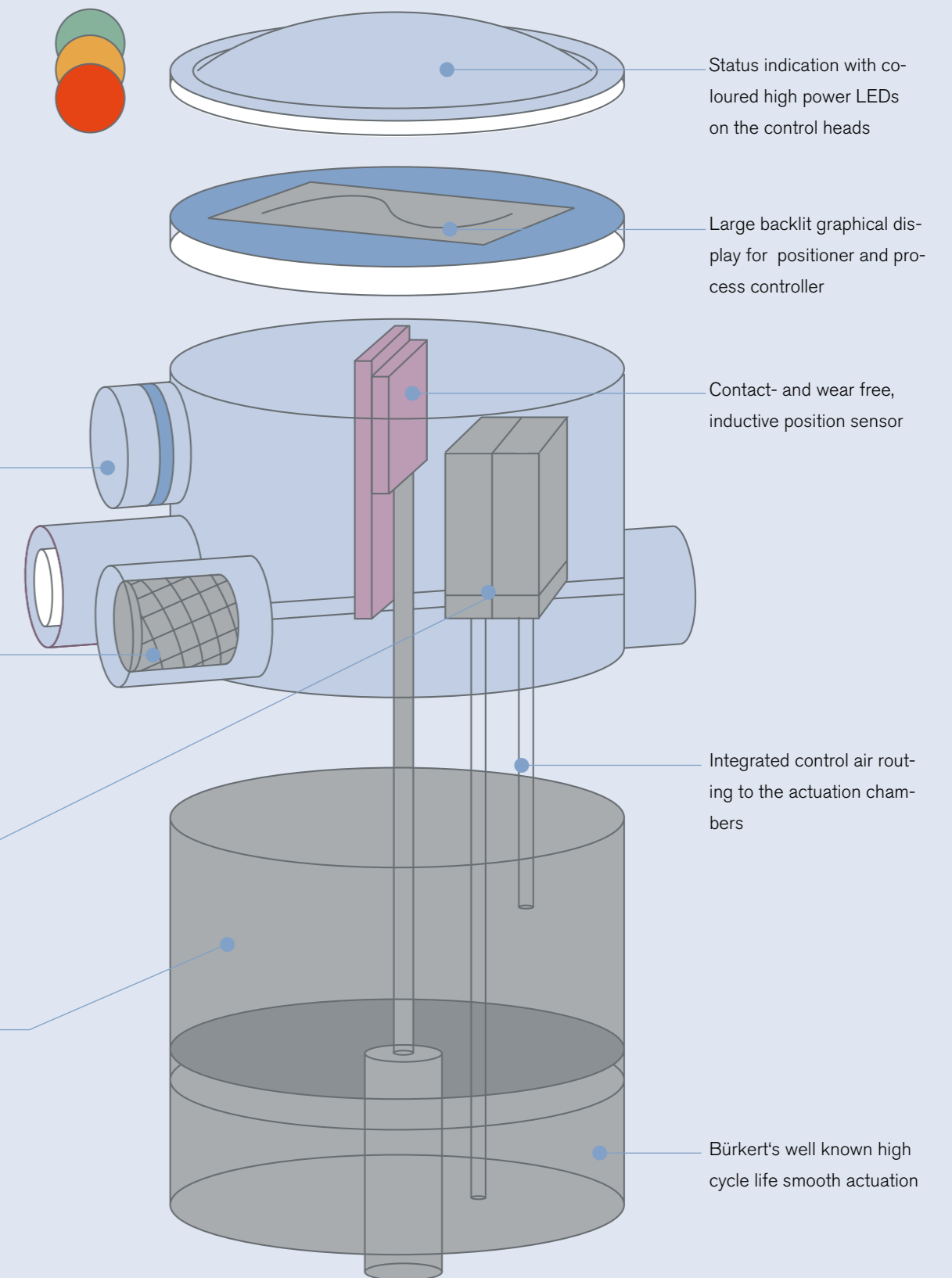

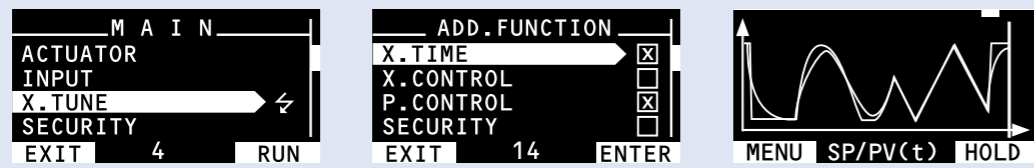

Intuitive operation: soft key combined with easy to understand menu structure

## Intelligent Control Valve Systems

### Complete and adaptable to individual needs

The innovative positioner and controller range offers a complete automation concept for integration into the most up-to-date control systems. Designed for tough and agile process environments the devices' design is particularly suited to the specific requirements of users in the food, cosmetic, beverage and pharmaceutical industries in terms of size, shape and cleanability, footprint and access code security.

### Flexibility to meet customer requirements

ELEMENT positioners and controllers offer flexible opportunities for optimizing the function for the application. Starting from the easy control task to the direct integration in fieldbus solutions with our different versions of positioners and process controllers the customized combinations for various applications are possible. ELEMENT is flexible in the choice of the valve housings no matter if it is for applications with steam, for heating and cooling processes or process media handling. Thanks to noncorrosive materials, practice oriented long life IP protection, unique compactness as well as innovations as the control air recycling to the drive chambers the ELEMENT range is the ideal solution for hygienic process technique.

As a modern control concept allows the intuitive operation of a powerful positioner and process controller. Despite the wide function range the operation is much easier; only if needed the additional functions are shown. Last but not least the parametrization of the positioner and the process controller is automated. Via P-Tune the structure and respective optimized control parameters of the process control loop are automatically and fastly detected.

### Configuration Software Package

Easy and up to date configurations tools are available online. Our local technical support is glad to help you.

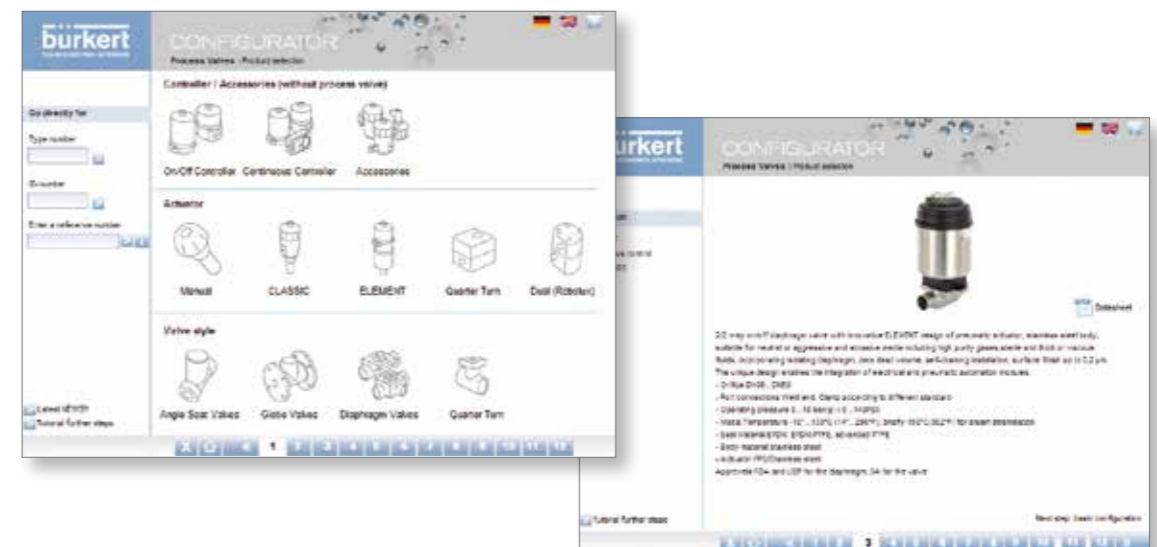



## Sensors and Transmitters

With the ELEMENT meter the (control) loop with level, pH, ORP, conductivity and flow measurement closes. As a part of a completely modular concept all measuring devices may be combined and configured to match your process needs.

At a glance you see the process status. The compact and sleek stainless steel design is especially suitable for demands in aggressive and hygienic areas. They are easy to clean, provide a perfect accuracy over a wide measurement range. Easy and quick implementation is guaranteed as all ELEMENT meter have standardized analog/digital outputs and a common HMI allows an easy operation.

Level		
<p><b>Type 8111</b> Vibrating level switch</p> 	<p><b>Type 8137</b> Radar level meter</p> 	<p><b>Type 8189</b> Guided microwave level meter</p> 
Analysis		
<p><b>Type 8202</b> pH/ORP meter with temperature sensor with/without display</p> 	<p><b>Type 8222</b> Conductivity meter with temperature sensor with/without display</p> 	<p><b>Typ 8228</b> Inductive conductivity meter with temperature sensor and optional display</p> 
Flow		
<p><b>Type 8026</b> Paddle wheel flowmeter Insertion</p> 	<p><b>Type 8036</b> Paddle wheel flowmeter Inline</p> 	<p><b>Types SE36 und S077</b> Oval gear flowmeter</p> 



## Bürkert – Close to you

For up-to-date addresses  
please visit us at  
[www.burkert.com](http://www.burkert.com).





**bürkert**  
FLUID CONTROL SYSTEMS

**Bürkert Fluid Control Systems**

Christian-Bürkert-Straße 13-17  
74653 Ingelfingen  
Deutschland

Tel.: +49 (0) 7940/10-0  
Fax: +49 (0) 7940/10-91 204

info@burkert.com  
www.burkert.com