

TLV[®]

PowerTrap

GT5C

**Compact Mechanical Pump
with Steam Trap Designed
to Eliminate Stall**

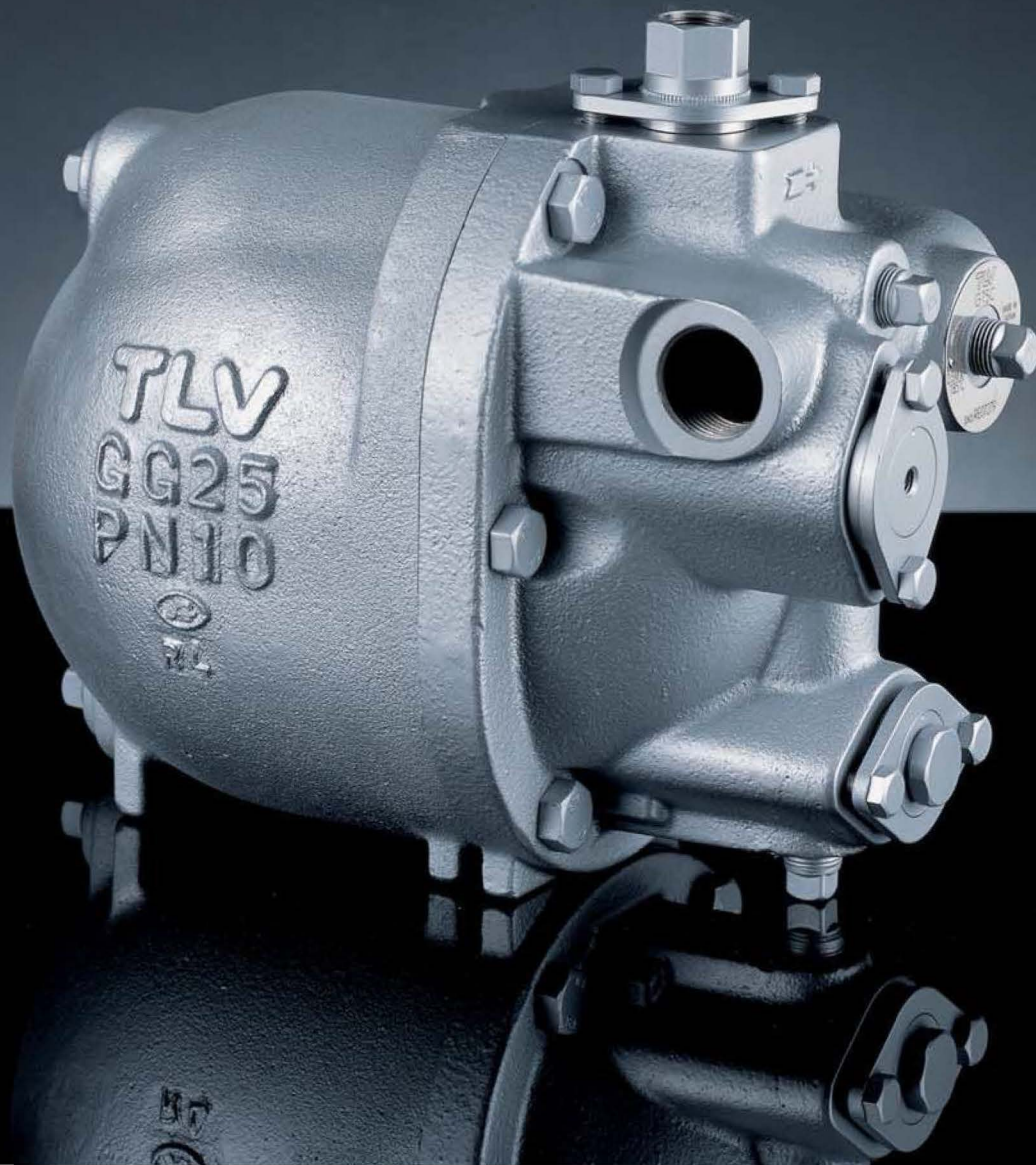

Stall-Eliminating Pump/Trap

for Small Steam-using Equipment

Is Your Air Conditioner, Dryer or Heater Damaged?

Does it Exhibit Signs of Water Hammer, Corrosion or Uneven Heating?

These problems could be caused by condensate accumulating in the equipment. This phenomenon is known as 'stall' and causes damage to equipment along with poor product quality if left untreated. As a steam trap cannot discharge condensate during a stall, further investment such as installing a vacuum pump in addition to the existing steam trap is required.

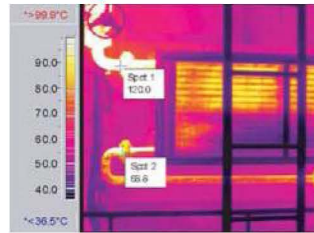

Air heater during the 'stall' phenomenon

Discharging Condensate Even Without Pressure Differential

TLV developed the **PowerTrap** GT series combination mechanical pump and steam trap to overcome this challenge. The **PowerTrap GT5C** is a practical solution, featuring a linear inlet/outlet, low filling head, and simple piping installation, eliminating anxiety about stall in your small steam-using equipment.

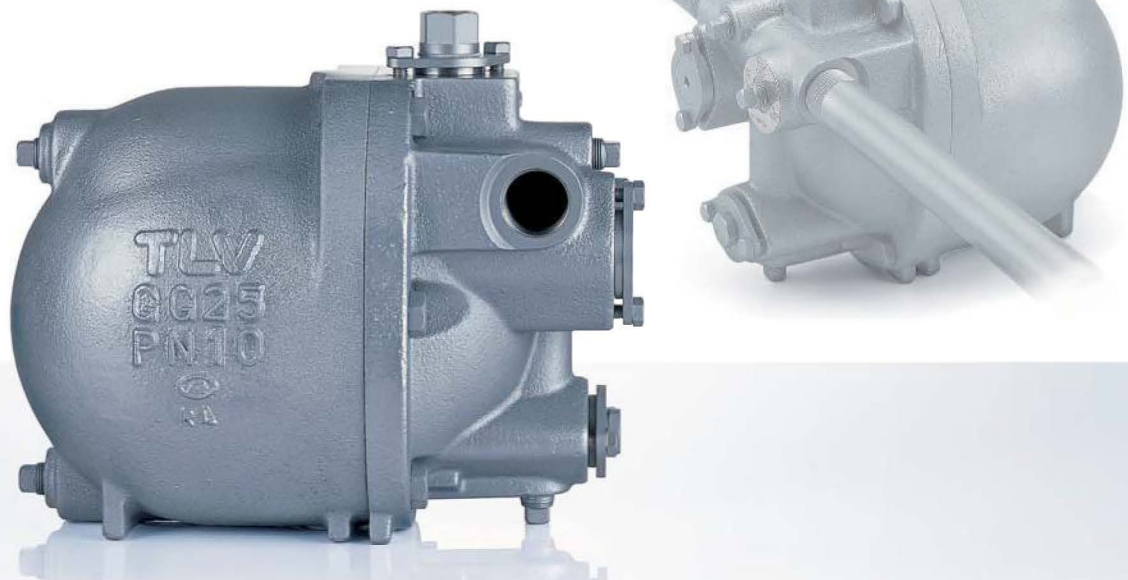

'Stall' Phenomenon

When the steam pressure inside a heat exchanger becomes lower than the outlet pressure (back pressure), condensate accumulates inside the equipment without being discharged from the trap causing damage/breakage by water hammer, and holes by corrosion and/or uneven heating.



The Stall Mechanism

When load in the equipment decreases, the control valve throttles and the pressure inside the equipment drops. When pressure inside the equipment (P_1) drops to back pressure (P_2) or below, the condensate accumulates in the equipment, causing stall. It is most frequent during low-load operation.

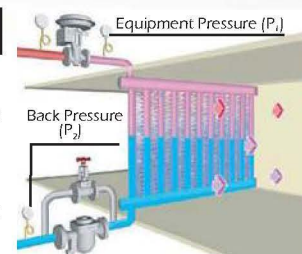

Mechanical Pump

Steam Trap

Compact Fusion of Mechanical Pump and Steam Trap with Low Filling Head

The **PowerTrap GT5C** is an incredibly compact mechanical pump with a steam trap not only discharging condensate when pressure inside the equipment is high, but also pumping out condensate by using steam as a motive medium when the pressure inside the equipment is low. The **GT5C** also enables simplified piping in comparison to existing mechanical pumps.

Installation Piping Example*

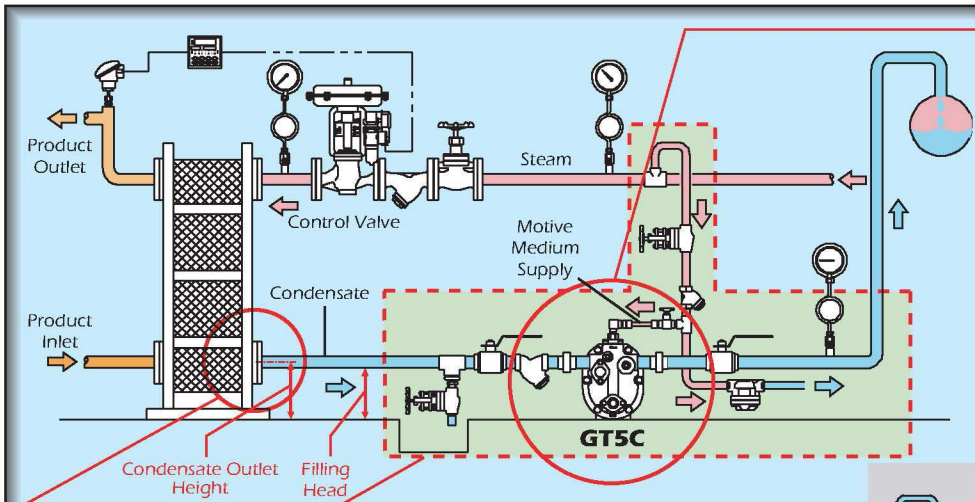

Easy Maintenance

- Inlet/outlet check valves and motive medium intake valve unit are removable while connected to the piping
- These valves/units can be removed by loosening two bolts
- The body can be disassembled by removing six bolts while still connected to the piping

*Actual installation differs depending on the desired discharge capacity and operating conditions, etc. Exhaust pipe recommended for some installations. See product specifications data sheet (SDS) for details.

Condensate Outlet Height of 6 7/16"

Usable with low condensate outlet heat exchangers (Min. Filling Head: 6")

No Exhaust Pipe Required / Simplified Piping

- Only motive medium intake pipe required - no exhaust pipe necessary*
- Inlet/outlet piping is linear, streamlined and efficient allowing for easy replacement of existing steam trap
- Built-in air vent and check valves reduce external installation

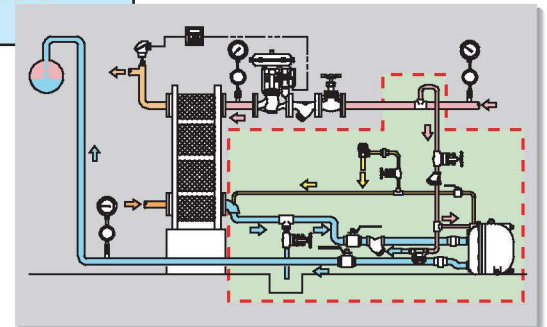

Installation Example for Existing Mechanical Pump*

Advanced Technology in a Compact Body

Suitable for Equipment with Low Condensate Outlets

The newly developed high performance snap-action unit allows for a low filling head

Highly Durable for a Long Service Life

The highly durable specialized bearing greatly extends the service life of moving parts

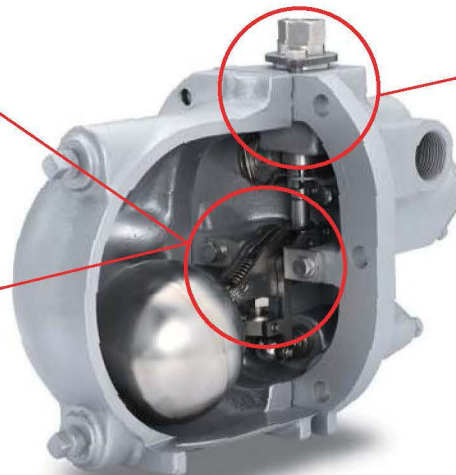

Stable Operation / Energy Conservation

Newly developed integrated motive intake and exhaust valve unit ensures stable operation and saves energy



Operation

Condensate Inflow

1 When condensate flows from the condensate inlet pipe through the inlet check valve into the body of the unit, the float rises and the main valve of the trap unit is open. When the inlet pressure is greater than the back pressure, the condensate passes through the outlet check valve and is discharged through the condensate outlet pipe (normal trapping function). When the back pressure is greater than the inlet pressure, the condensate is not discharged and collects in the body of the unit.

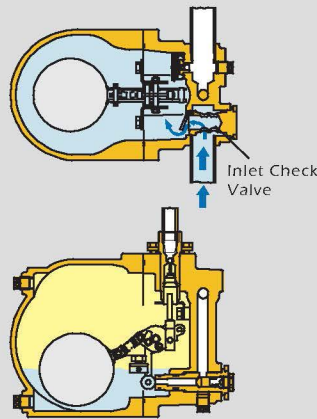

Condensate Discharge

2 When the float rises to its highest level, the push rod on the snap-action unit rises quickly, simultaneously closing the exhaust valve and opening the intake (motive medium) valve. The pressure supplied by the motive medium causes the internal pressure in the unit to become greater than the back pressure. The inlet check valve closes and the outlet check valve is pushed open, thus discharging the condensate in the unit through the outlet pipe.

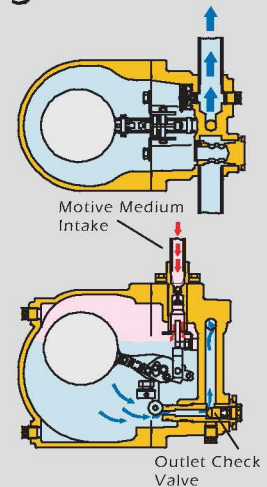

Configuration and Specifications

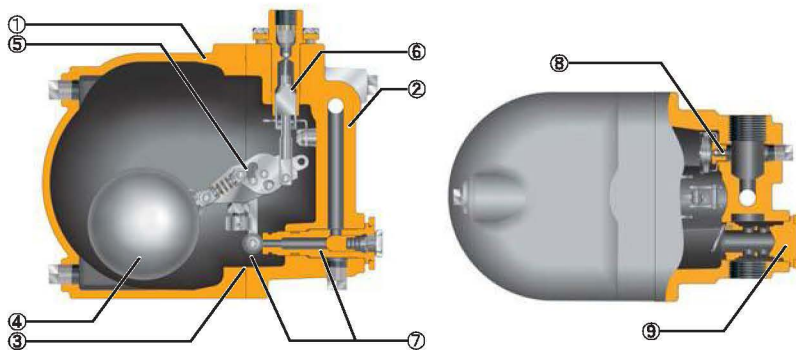

Material

①	Body	Cast Iron, Stainless Steel
②	Cover	Cast Iron, Stainless Steel
③	Cover Gasket	Fluorine Resin
④	Float	Stainless Steel
⑤	Snap-action Unit	Stainless Steel
⑥	Intake/Exhaust Valve Unit	Stainless Steel
⑦	Trap Unit (with Outlet Check Valve)	Stainless Steel
⑧	Air Vent Unit	Stainless Steel
⑨	Inlet Check Valve	Stainless Steel

Specifications

Connection	Pumped Medium Inlet/Outlet	Screwed
	Motive Medium & Pump Exhaust	Screwed
Size (in)	Pumped Medium Inlet/Outlet	1 / 1
	Motive Medium Inlet	1/2
	Pump Exhaust Outlet	3/8
Max. Operating Pressure PMO		75 psig
Max. Operating Temperature TMO		365 °F
Max. Allowable Pressure PMA		150 psig
Max. Allowable Temperature TMA		428 °F
Motive Medium Pressure Range		5 – 75 psig
Maximum Allowable Back Pressure		7 psi less than motive medium pressure used
Volume of Each Discharge Cycle		Approx. 3/8 gal
Motive Medium		Saturated steam
Pumped Medium		Steam condensate

Dimensions

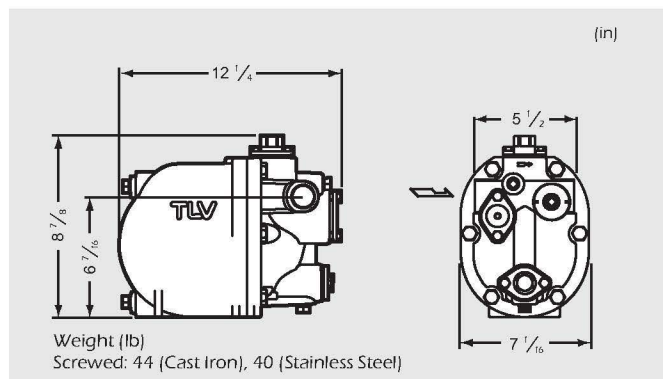

Note: Condensate discharge capacity is shown on the GT5C product specifications data sheet (SDS)

CAUTION To avoid abnormal operation, accidents or serious injury, DO NOT use this product outside the specification range. Local regulations may restrict this product below the conditions quoted.

CAUTION DO NOT DISASSEMBLE OR REMOVE THIS PRODUCT WHILE IT IS UNDER PRESSURE. Allow internal pressure of this product to equal atmospheric pressure and its surface to cool to room temperature before disassembling or removing. Failure to do so could cause burns or other injury. READ INSTRUCTION MANUAL CAREFULLY.

TLV CORPORATION

13901 South Lakes Drive, Charlotte, NC 28273-6790
 Phone: 704-597-9070 Fax: 704-583-1610
 E-mail: tlv@tlvengineering.com
 For Technical Service 1-800 "TLV TRAP"



Manufacturer

TLV CO., LTD.
 Kakogawa, Japan

is approved by LRQA Ltd. to ISO 9001/14001

ISO 9001/ISO 14001

