

# Translink™ Parallel Link Truck Scale Assembly

Rice Lake Weighing Systems



Mount only; does not include load cell  
Picture is a representation of actual product

The Translink parallel link truck scale assembly is designed for use with Rice Lake Weighing Systems' RL75223 and RL75040A, VPG Revere's 5223 or VPG Sensortronics® 65040A load cells. This design allows the scale platform to move freely in all directions on a horizontal plane while causing the platform to self-center because of the pendulous action of the links. The unique parallel link design eliminates the need for costly and troublesome checkrods. Simply install platform bumpers and forget about over-travel. This mount is ideal for heavy-capacity weigh bridges.

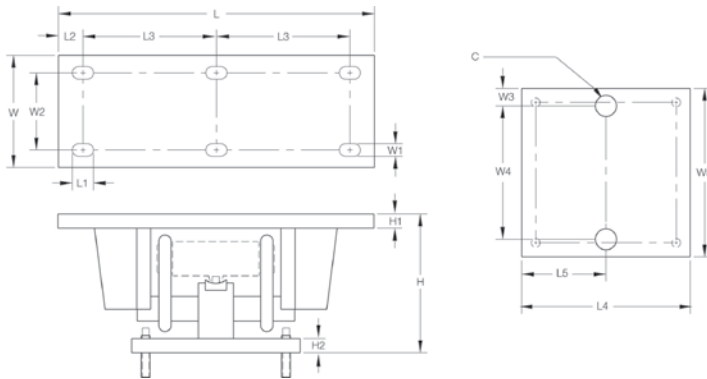

## Dimensions

Rated Capacity	C	H	H1	H2	L	L1	L2	L3	L4	L5	W	W1	W2	W3	W4	W5
<b>lb/in</b>																
50,000-100,000 (RL75223, 5223)	1.50	12.93	1.00	1.00	22.50	1.50	1.75	9.50	11.75	5.88	7.75	0.91	5.25	1.25	9.25	11.75
25,000-40,000 (RL75040A, 65040A)	1.50	9.88	1.00	1.00	18.50	1.50	1.75	7.50	11.75	5.88	7.75	0.91	5.25	1.25	9.25	11.75
50,000-75,000 (RL75040A, 65040A)	1.50	12.82	1.00	1.00	22.50	1.50	1.75	9.50	11.75	5.88	7.75	0.91	5.25	1.25	9.25	11.75
<b>kg/mm</b>																
22,679.6-45,359.4	38.1	328.4	25.4	25.4	571.5	37.5	44.5	241.3	298.5	149.4	196.9	23.1	133.4	31.8	235.0	298.4
11,339.8-18,143.7	38.1	251.0	25.4	25.4	469.9	37.5	44.5	190.5	298.5	149.4	196.9	23.1	133.4	31.8	235.0	298.4
22,679.6-34,019.4	38.1	325.6	25.4	25.4	571.5	37.5	44.5	241.3	298.5	149.4	196.9	23.1	133.4	31.8	235.0	298.4

## Order Information

Load Rating (Per Module)	Part#	Price
<b>For Use With RL75223, 5223 Load Cells</b>		
50,000 lb-100,000 lb	22,679.6 kg-45,359.4 kg	<b>17970</b>
<b>For Use With RL75040A, 65040A Load Cells</b>		
25,000 lb-40,000 lb	11,339.8 kg-18,143.7 kg	<b>17971</b>
50,000 lb-75,000 lb	22,679.6 kg-34,019.4 kg	<b>17972</b>

Mount only; does not include load cell

See load cell model RL75223 (RLWS), load cell model RL75040 (RLWS) and model 65040A (VPG Sensortronics) specifications

## Standard Features

- Capacities: 25,000 lb-100,000 lb (11,339.8 kg-45,359.4 kg)
- Center-supported, end-loaded, double-ended shear beam design
- Free movement in all directions on the horizontal plane with virtually no friction
- Links provide optimal loading conditions for the cell
- Completely self-centering
- Requires no check rods
- Utilizes cells with 3 mV/V output
- Models available are RL75223 and RL75040, RTI 5223 and VPG® Sensortronics 65040A load cells

## Applications

- Truck scale mount
- Heavy-capacity horizontal tanks