

### Mueller Automatic Control Valves

With the 2017 acquisition of Singer Valve, Mueller Co. designs and manufactures automatic control valves for the global water industry. Since 1957, our pilot operated diaphragm control valves have been installed on virtually every continent around the world. Whether it is water loss management in Southeast Asia, water conservation concerns in Saudi Arabia, urban distribution demands in the United States or fire valves in Indonesia or South Korea, we provide water management solutions to governments, cities, companies and contractors around the world.

Many of our innovative products are ones that have been born out of our inherent desire to solve an application challenge. Presented with a problem, our team of electronic, instrumentation and control valve specialists are relentless in their research and design until they find a solution.

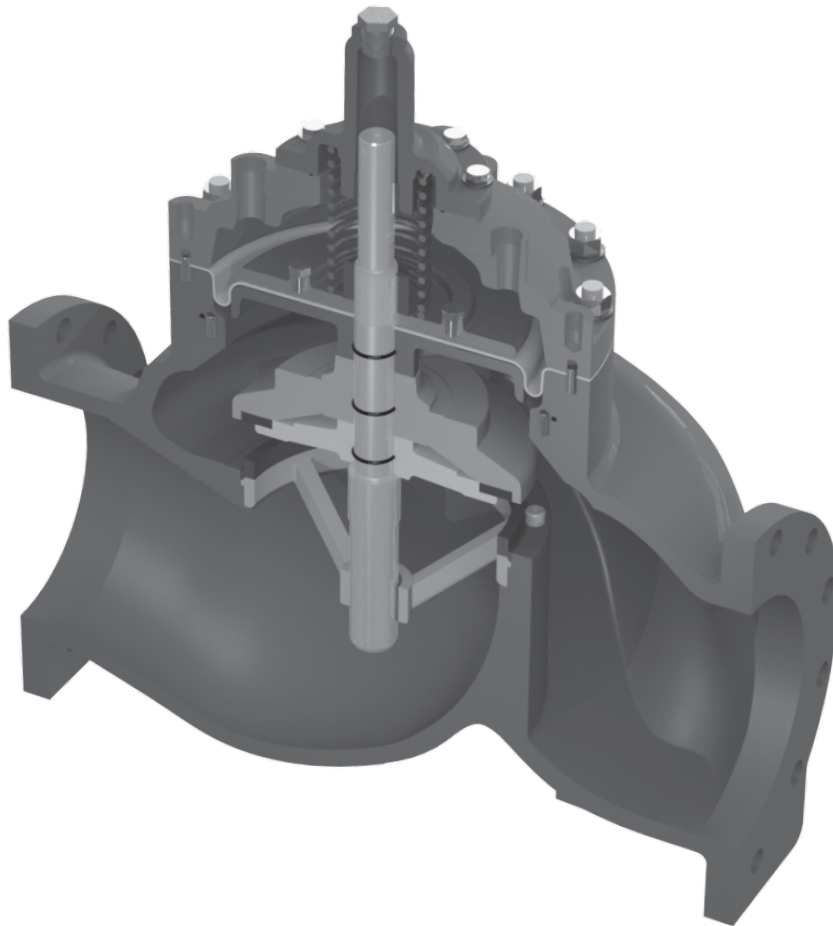

- **AISI Stainless Steel Components** - our AISI 316 stainless steel spring and stem are corrosion resistant. The AISI 316 stainless steel seat ring is guaranteed for the life of the valve.
- **Removable Stem Cap** - the removable, separate stem cap reduces bent stems, which reduces inspection & assembly time.
- **Stainless Steel External Fasteners** - stainless steel external fasteners prevent rust, reducing maintenance.
- **Smaller, Lighter Cover** - smaller, lighter cover improves worker safety and reduces maintenance.
- **Removable Bonnet** - bonnet removes easily thanks to locating-pin technology.
- **Anti-Vibration Fasteners** - stainless steel anti-vibration fasteners create a dependable maintenance-free seat.
- **Extra Threaded Taps** - extra threaded taps on main valve allow for easy re-orientation of pilot system.
- **Oversized Wrench Flat** - accessible oversized wrench flat means easy disassembly of inner valve.
- **Rolling Diaphragm Design\*** - exclusive rolling diaphragm design offers unequalled low flow stability.
- **Fusion Epoxy Coating** - coated inside and outside for improved flow and resistance to wear.
- **EPDM/Buna-N Elastomer Diaphragm** - EPDM/Buna-N elastomer diaphragm is chlorine and chlormine resistant.

*\*Not available in all size/model combinations. Consult with Mueller Co.*

**MODEL M106-RPS-8700A  
PRESSURE RELIEF VALVE****M106-RPS-8700A**

The M106-RPS-8700A pressure relief valve, which is UL/FM labelled and listed, automatically relieves excess pressure in the fire protection system to discharge. The RPS series valves will also automatically modulate to relieve excess pump capacity during pump start up and shut down, allowing the pump to operate without causing surges.

These relief valves are based on the M106-PG or MA106-PG main valves and come in complete range of sizes from 2-1/2 in/65 mm to 8 in/200 mm. In typical pressure relief application, the angle style MA106-RPS-8700A is often the preferred selection.

**Features**

- UL Listed to ANSI/UL 1478A FM Approved to FM 1361
- Reliable diaphragm actuated
- Hydraulically operated design
- Class 150 and 300 flanges
- Stainless steel fasteners
- Heat fused red epoxy coating
- Available in globe and angle style

**Standard materials for pilot system components**

- ASTM B62 bronze or ASTM B16 brass
- AISI 303/316 stainless steel trim
- Buna-N/EPDM diaphragm and seals

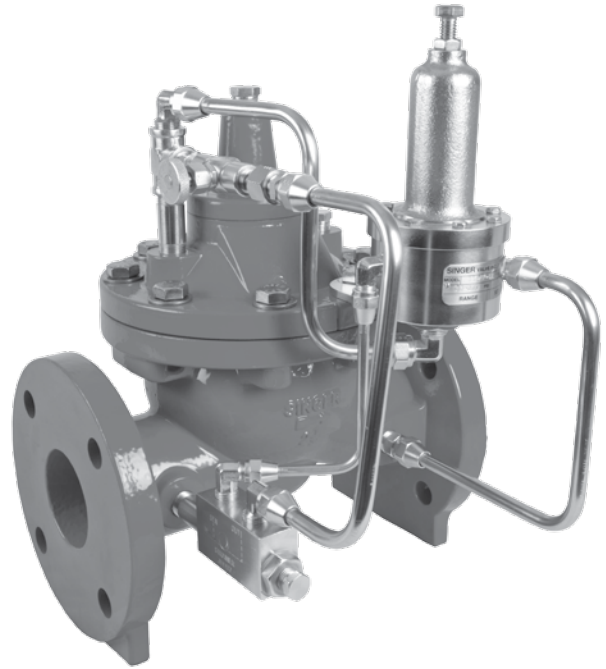
**Schematic Drawing**

1. Main Valve - M106-PG, or MA106-PG, Flanged 2-1/2 in/65 mm to 8 in/200 mm
2. Isolation Valve - lockable (optional)
3. Strainer - standard 4 in/100 mm and larger
4. Fixed Restriction- 1/8 in/3.2 mm
5. Model M852-B Closing Speed Control
6. Model M81-RP pilot - 30 to 200 psig/2.07 to 13.8 barg - optional 100 to 300 psig/6.9 to 20.7 barg

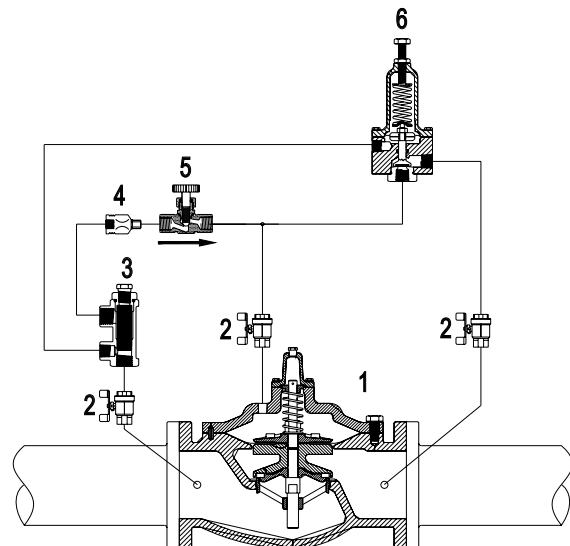
**Schematic A-8700A**

**UL / FM**



SECTION  
**G-1**

**FIRE PROTECTION PRODUCTS**

**MUELLER®  
AUTOMATIC CONTROL VALVES**

Rev. 6-17

Shaded area indicates change



**Reliable Connections™**

[www.muellercompany.com](http://www.muellercompany.com) • [moreinfo@muellercompany.com](mailto:moreinfo@muellercompany.com)

**MODEL M18-FR  
PRESSURE RELIEF VALVE**

**M18-FR**

The M18-FR is a remote sensing, high capacity, spring and diaphragm operated, normally closed valve. The inner valve is held closed by the spring. When the sensed pressure increases above the spring setting, the valve opens.

**Features**

- Available in globe and angle style
- Available sizes ½ inch and ¾ inch
- Direct acting
- Drip tight closing
- Accurate pressure control
- UL listed to ANSI/UL 1478A FM approved to FM 1359

**Specifications**

- The normally closed valve shall be of stainless steel construction with a spring to adjust the opening pressure.
- The inner valve shall be of stainless steel 316 construction and the inner valve shall have EPDM resilient compound for seating.
- A separate port will sense pressure to open the valve when system pressure exceeds the valve set-point.
- Maximum working temperature: 180° F/82° C
- Maximum working pressure: 400 psig/27.6 barg



	Spring Range	Approximate PSI Per Turn
Standard	20 to 200 psig 1.38 to 13.8 barg)	22 psig (1.52 barg)
Optional	10 to 75 psig (0.69 to 5.17 barg)	9 psig (0.62 barg)
	100 to 300 psig (6.9 to 20.7 barg)	49 psig (3.38 barg)

Flow Rates		
Size	Cv	Max Flow (GPM)
1/2"	6.8	70
1/2" angle	6.9	76
3/4"	8.3	84
3/4" angle	8.4	88

## FIRE PROTECTION PRODUCTS

### Schematic Drawing

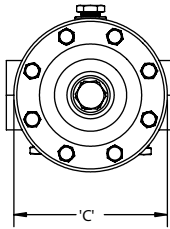
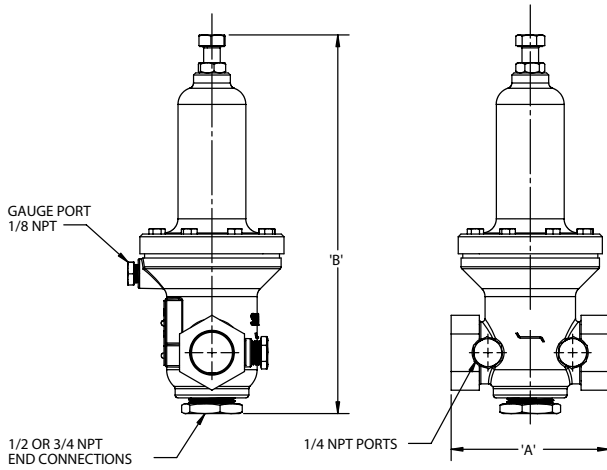

	US Unite	SI Units
A	3.50"	90 mm
B	9.06"	230 mm
C	3.19"	81 mm
Weight	4.05 lbs.	1.8 kg

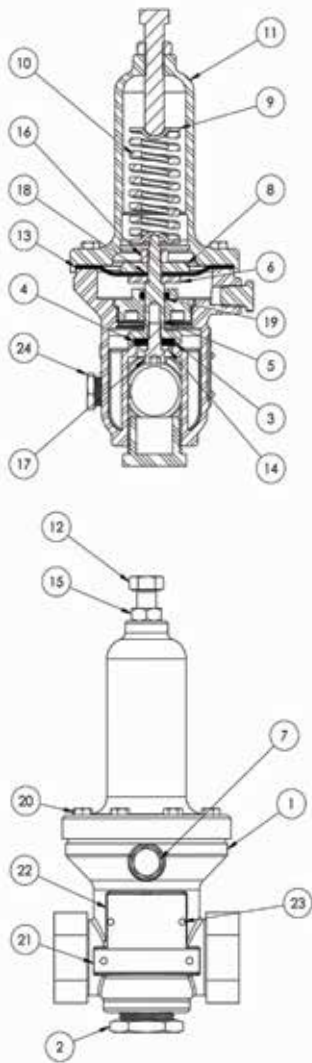

Part	Description
1	Body
2	Plug (stainless steel)
3	Inner valve (18FR)
4	Resilient disc
5	Bushing (threaded)
6	Clamp plate (lower)
7	Plug (1/8 NPT stainless steel)
8	Clamp plate
9	Spring step
10	Spring
11	Spring casing
12	Hbolt 0.375-16x2.06 (machined)
13	Diaphragm pilot (EPDM)
14	Retainer disc
15	Nut - hex jam 3/8-16 UNC
16	Nut - hex 1/4-20 UNC
17	Socket head cap screw
18	O-ring
19	O-ring
20	Screw - hex head
21	Tag (Mueller)
22	Tag (UL Approved)
23	Rivet U drive
24	Plug - 1/4 NPT

**MODEL M016-PR-10159 UL/  
M106-PR-8702A ULC  
PRESSURE REDUCING VALVE**

**M016-PR-10159 UL / M106-PR-8702A ULC**

The M106-PR, which is UL and ULC labelled and listed, is ideal for automatically reducing a higher inlet pressure to a steady lower discharge pressure, regardless of fluctuations in flow or inlet pressure.

The valves are based on the M106-PG or MA106PG control valves and are available in a complete range of sizes from 2 in/50 mm to 8 in/200 mm (sizes depend on UL classification). In typical pressure reducing applications, the globe style M106-PR is often the preferred valve style.

**Features**

- UL and ULC listed to ANSI/UL 1468, 1739
- Reliable diaphragm actuated
- Hydraulically operated design
- Class 150, 300 flanges, grooved & threaded
- Stainless steel fasteners
- Heat fused red epoxy coating
- Available in globe and angle style

**Standard materials for pilot system components**

- ASTM B62 bronze or ASTM B16 brass
- AISI 303/316 stainless steel trim
- Buna-N / EPDM diaphragm and seals

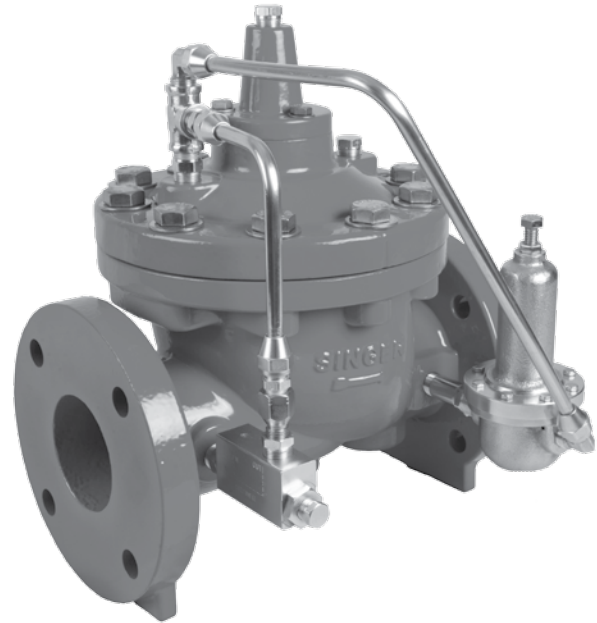
**PR-10159 - UL Listed**

Valve Size	Maximum Pressure	
	Class 150	Class 300
2 in/50mm - 4 in/100 mm	175 psig/12.06 barg	300 psig/20.68 barg
6 in/150mm - 8 in/200 mm	175 psig/12.06 barg	-

**PR-8702A - ULC Listed**

Valve Size	Maximum Pressure	
	Class 150	Class 300
Globe 2 in/50mm - 8 in/200 mm	175 psig/12.06 barg	400 psig/27.60 barg
Angle 2 in/50mm - 8 in/200 mm	175 psig/12.06 barg	400 psig/27.60 barg

**Schematic Drawing**

1. Main Valve - Model M106-PG, SPG or GE, Globe or Angle, 2 in/50 mm - 8 in/200 mm UL (2 in/50 mm, 8 in/200 mm ULC) Grooved - 2 in/50 mm to 8 in/200 mm, Globe style only
2. Lockable Isolation Valve MJ0044A (optional)
3. Strainer MJ0098A - standard 4 in/100 mm & larger
4. Fixed Restriction
5. Pressure Reducing Pilot Model M161PR (UL), M160PR (ULC)
  - Range: 30 to 165 psig/2.06 to 11.37 barg (UL)
  - Range: 20 to 200 psig/1.38 to 13.8 barg (ULC)
  - Optional 100-300 psig/3.89 to 20.68 barg (ULC)

Note: Maximum outlet setting for both UL & ULC pilots is 165 psig/11.37 barg

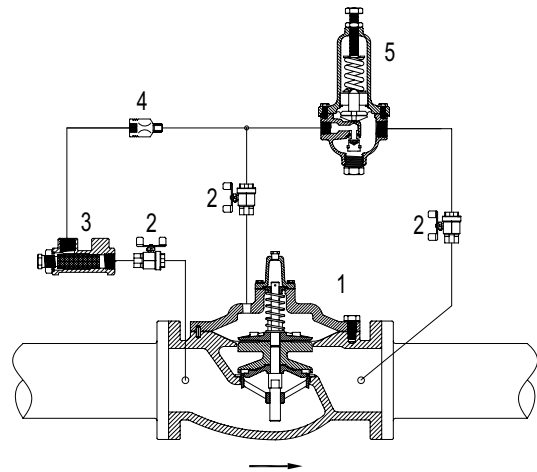
**Schematic A-10159B UL**

Note: UL listed valves use rolling diaphragm on 6 in/150 mm and 8 in/200 mm valves. ULC listed valves use flat diaphragms only. For UL dimensions, ULC dimensions and Grooved dimensions, see page 26.

## FIRE PROTECTION PRODUCTS

### M106-F-TYPE 4

The Model M106-F-Type 4 modulating float valves are based on the M106-PG main valve. They are ideal for balancing the inflow and outflow demand into the storage tank and maintaining level at the designated maximum.

The valve closes drip-tight at the maximum level and modulates to maintain the tank level. The float pilot is remotely installed at the high level in the storage tank. Pilot connections to the main valve are connected in the field. As the tank level drops the main valve is opened proportionally to increase the filling rate. Movement of the main stem alters the size of the closing restriction, interrupting the tendency of the valve to hunt.

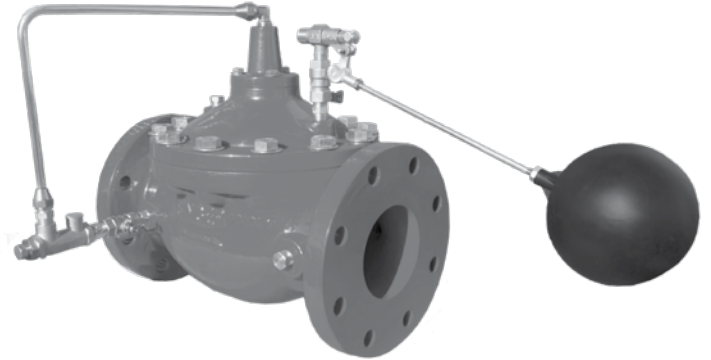

### Features

- Maintains relatively constant level
- Automatic compensation for level draw-down
- Standard integral damping reduces hunting
- Drip-tight at high level shut-off
- Low supply pressure options

### Standard materials for pilot system components

- ASTM B62 bronze or ASTM B16 brass
- Stainless steel

*Note: The stilling well and the connections between main valve and pilot completed by others.*

### Schematic Drawing

1. Main Valve - M106-PG, SPG or GE, Internal Needle Stem Valve (INSV) built into stem

Available in 1/2 in/15 mm to 8 in/200 mm, FNTF  
1/2 in/15 mm to 1 in/15 mm, Flanged 1-1/2 in/40 mm to 8 in/200 mm, Grooved 2 in/50 mm to 8 in/200mm, Globe style only

2. Isolation valve
3. Strainer - 40 mesh stainless steel screen
4. R400 Float Pilot comes with plastic float

*Note: Schematic shown for 2.5 in/65 mm and larger*

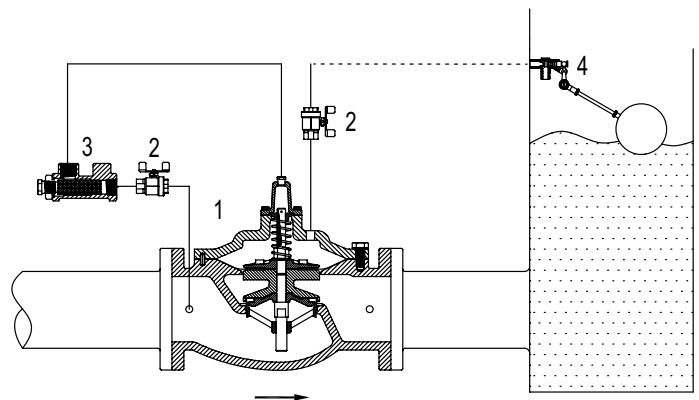

**Schematic A-0608D**

**MODEL M106-F-TYPE 5  
NON-MODULATING FLOAT VALVE****M106-F-TYPE 5**

The M106-F-Type 5 non-modulating float valves are based on the M106-PG main valve. It is ideal for allowing normal forward flow to fill water tanks to a desired high level and where the pilot and valve of the storage tanks are easily accessible.

The valve functions as a two position valve, either open or closed. The valve remains closed when the tank level drops, until the float reaches the pre-determined adjustable minimum tank level. The F-Type 5 valve then opens to refill the tank and closes tightly when high water level is achieved.

**Features**

- No overflow, drip-tight closure
- Adjustable draw down
- Easily adjustable level settings
- Low supply pressure options

**Standard materials for pilot system components**

- ASTM B62 bronze or ASTM B16 brass
- Stainless steel

*Note: The stilling well and the connections between main valve and pilot completed by others.*

**Schematic Drawing**

1. Main Valve - M106-PG, SPG or GE  
Available in 1 in/25mm to 8 in/200 mm, FNTP 1 in/25 mm to 3 in/80 mm, Flanged 1 1/2 in/40 mm to 8 in/200 mm, Grooved 2 in/50 mm to 8 in/200 mm, Globe style only
2. Isolation valve
3. Strainer - 40 mesh stainless steel screen
4. Model M43 Float Pilot comes with Stainless Steel float, 4 ft/1.2 m stainless steel rod - 8" (200mm) & larger, - 2 ft/600 mm stainless steel rod - 6" (150 mm) and smaller

*Note: Schematic shown for 2.5 in/65 mm and larger*

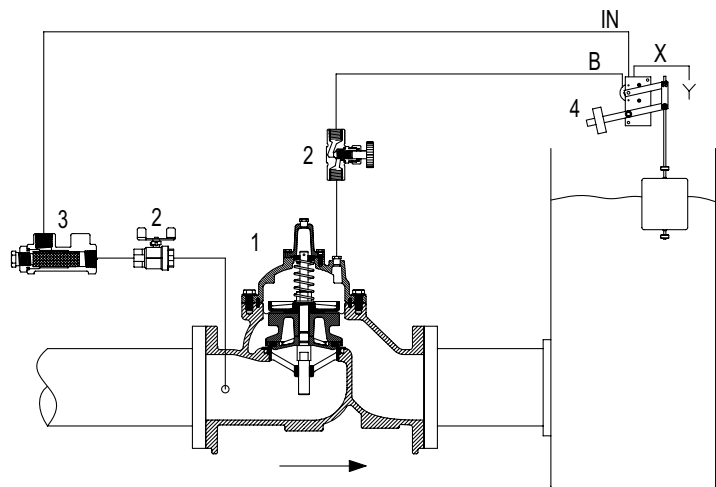
**Schematic A-0421C**

*8" (200mm) stilling well must be provided around float.*



## FIRE PROTECTION PRODUCTS

### Dimensions

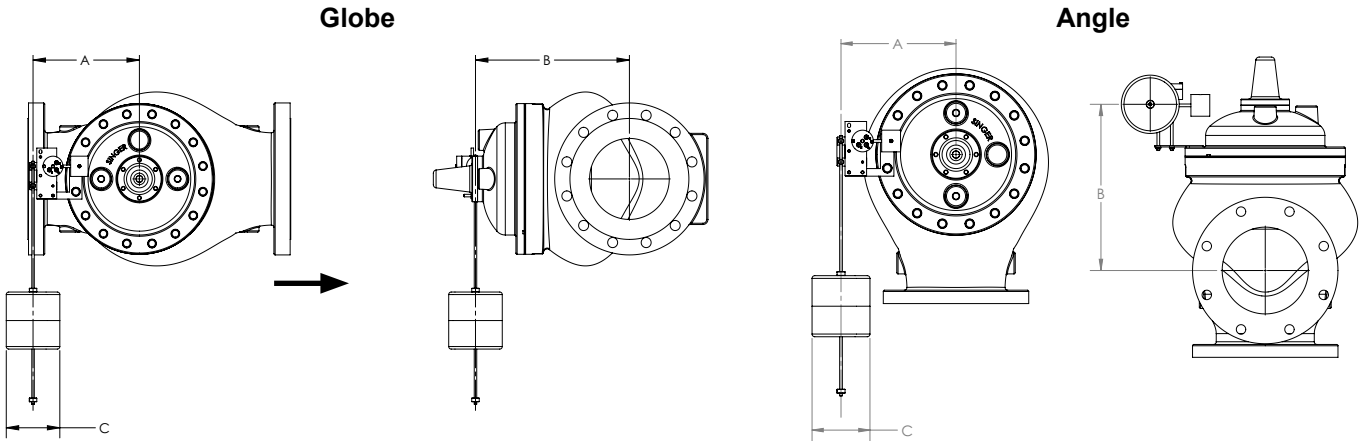

#### Globe

Description			US Units (inches)			Metric Units (mm)		
US Units (inches)	Metric Units (mm)	Body	A	B	C	A	B	C
0.5	15	M106	2.50	4.25	5.38	64	108	137
1	25	M106	5.50	4.75	5.38	140	121	137
1.5	40	M106	6.00	6.75	5.38	152	171	137
2	50	M106	6.25	7.00	5.38	159	178	137
2.5	65	M106	6.75	7.75	5.38	171	197	137
3	75	M106	7.25	8.25	5.38	184	210	137
3	75	M206	6.25	7.06	5.38	159	179	137
4	100	M106	8.00	9.50	5.38	203	241	137
4	100	M106	7.25	7.50	5.38	184	191	137
6	150	MS106	10.25	10.50	5.38	260	267	137
6	150	M206	8.00	8.75	5.38	203	222	137
8	200	MS106	10.23	11.33	5.38	260	288	137
8	200	M206	10.25	9.75	5.38	260	248	137

#### Angle

Description			US Units (inches)			Metric Units (mm)		
US Units (inches)	Metric Units (mm)	Body	A	B	C	A	B	C
1.5	40	MA106	-	-	5.38	-	-	137
2	50	MA106	6.25	7.00	5.38	159	178	137
2.5	65	MA106	6.75	7.75	5.38	171	197	137
3	75	MA106	7.25	7.06	5.38	184	179	137
4	100	MA106	8.25	9.00	5.38	210	229	137
4	100	MA206	7.25	7.50	5.38	184	191	137
6	150	MA206	8.25	8.75	5.38	210	222	137
6	150	MSA206	10.50	10.00	5.38	267	254	137
8	200	MSA106	10.23	11.94	5.38	260	303	137
8	200	MA206	10.50	9.75	5.38	267	248	137

**MODEL M106-A-TYPE 2 ONE-WAY  
FLOW ALTITUDE CONTROL VALVE****M106-A-TYPE 2**

The M106-A-Type 2 altitude control valves are based on the M106-PG main valve, and is ideal for maintaining a preset maximum water level.

The valve functions as a two position control valve, either fully open or fully closed. The Type 2 valve allows normal forward flow to fill the storage tank to the maximum level and then closes drip-tight at the set-point. It opens to refill the tank once the level drops a fixed distance below the high water level.

*Note: This valve does not operate as a check valve to prevent reverse flow.*

**Features**

- No overflows - high level shut-off maintained to close tolerances
- Superior repeatability
- Positive shut-off
- Easily serviceable at ground level

**Standard materials for pilot system components**

- Ductile iron
- Brass
- Stainless steel
- Copper

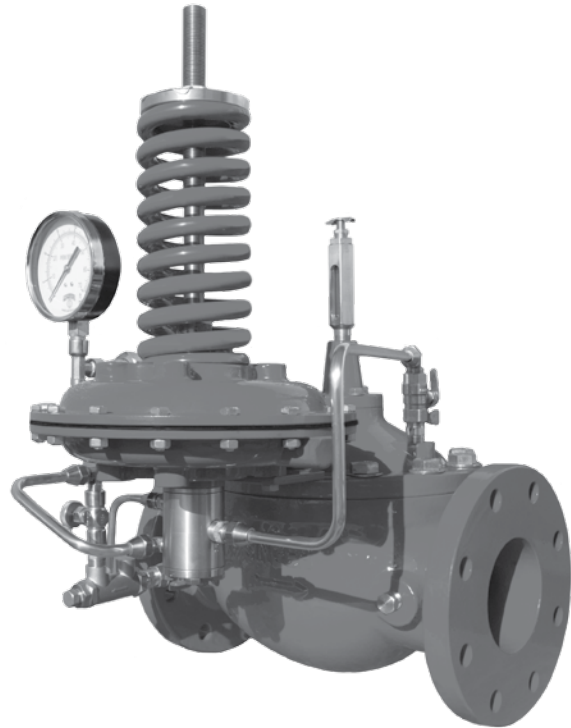
**Schematic Drawing**

1. Main Valve - M106-PG, SPG or GE with X107 visual position indicator.

Available in 2 in/50 mm to 8 in/200 mm, FNTF  
2 in/50 mm to 3 in/80 mm, Flanged 2-1/2 in/  
63 mm to 8 in/200 mm, Grooved 2 in/50 mm to  
8 in/200 mm, Globe style only

2. Strainer - 40 mesh stainless steel screen
3. Model M301-4 altitude pilot
4. Closing speed control
5. Altitude Gauge - dual scale - feet and meter
6. Isolation valve
7. Union
8. Sensing connection to storage tank  
(complete in field by others)
9. Isolation valve

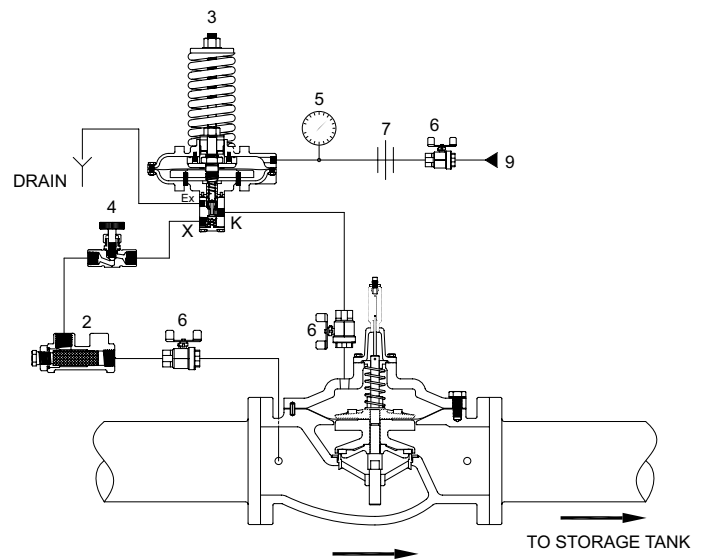
**Schematic A-0413C**

## FIRE PROTECTION PRODUCTS

### M106-A-TYPE 4

The M106-A-Type 4 altitude control valves are based on the M106-PG main valve, and is ideal for maintaining a preset maximum water level. The valve functions as a two position control valve, either fully open or fully closed.

The Type 4 allows normal forward flow to fill the storage tank to the maximum level, then closes drip-tight at the set-point. It opens to refill the tank once the level drops an adjustable amount below the high water level.

*Note: Distribution from the storage tank is through a separate pipeline. This valve does not operate as a check valve to prevent reverse flow.*

### Features

- No overflows
- Adjustable draw-down level (differential) set-point
- Superior repeatability
- Positive shut-off
- Adjustable draw-down for improved water cycling

### Standard materials for pilot system components

- Ductile iron
- Brass
- Stainless steel
- Copper

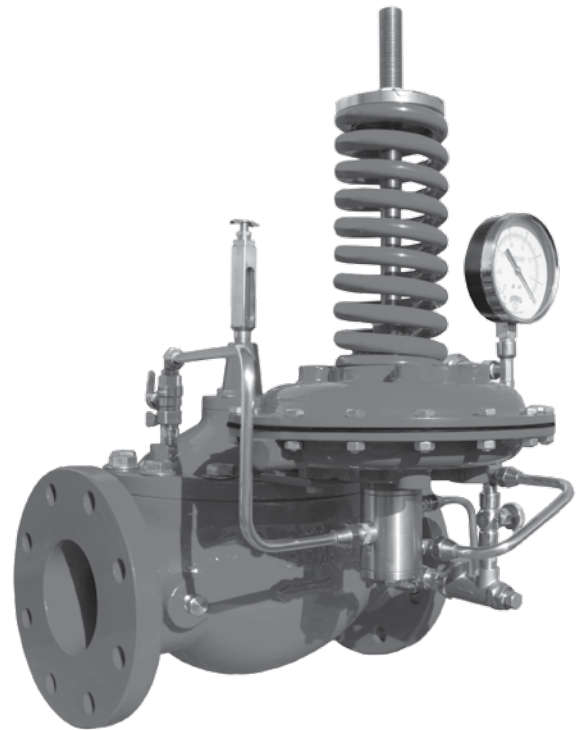

### Schematic Drawing

1. Main Valve - M106-PG, SPG or GE with X107 visual position indicator.

Available in 2 in/50 mm to 8 in/200 mm, FNTF  
2 in/50 mm to 3 in/80 mm, Flanged 2-1/2 in/  
63 mm to 8 in/200 mm, Grooved 2 in/50 mm to  
8 in/200 mm, Globe style only

2. Isolation valve
3. Strainer - 40 mesh stainless steel screen
4. Closing speed control
5. Model M301-4 altitude pilot
6. Model M106-RD differential pilot
7. Altitude gauge - dual scale - feet & meter
8. Sensing connection to storage tank (complete in field)
9. Model M10 check valve
10. Union

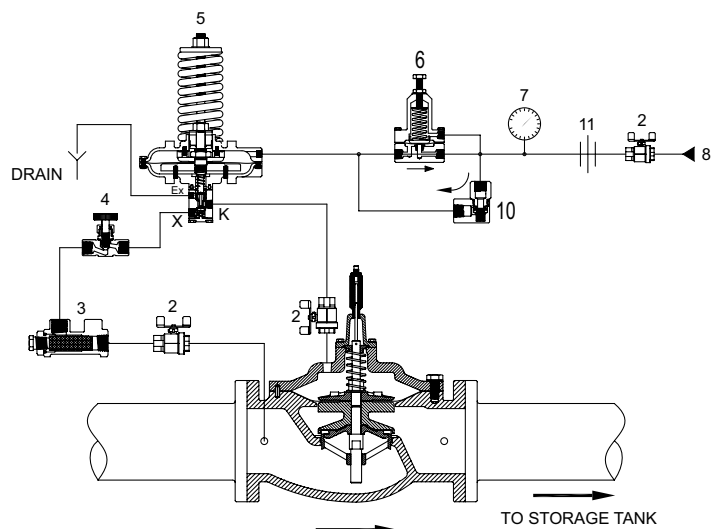

**Schematic A-0415C**

**M106-PG / MS106-PG & M106-GE**

The M106-PG series control valve is designed to suit a large variety of applications such as pressure, flow or level control. This hydraulically operated valve introduces or releases water from the control chamber above the diaphragm to effectively maintain accurate water control.

**Features**

- Available in Globe & Angle styles

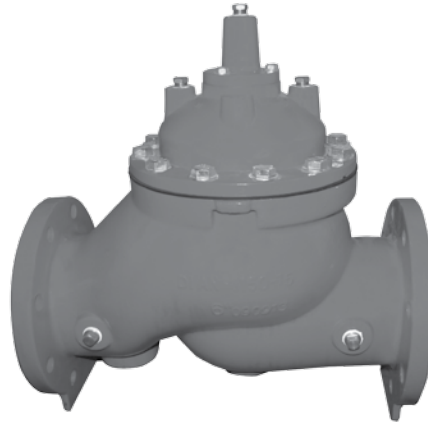
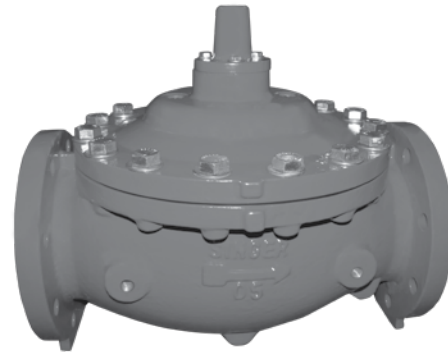
**MS106-PG****M106-PG Globe - Flat****Schematic Drawing**

1. Removeable stem cap
2. ASTM A536 ductile iron construction
3. Diaphragm Buna-N or EPDM
4. Buna-N or EPDM resilient disc
5. AISI 316 stainless steel seat
6. AISI 316 stainless steel stem
7. HFE coating AKZO RAL 3000 Fire Red

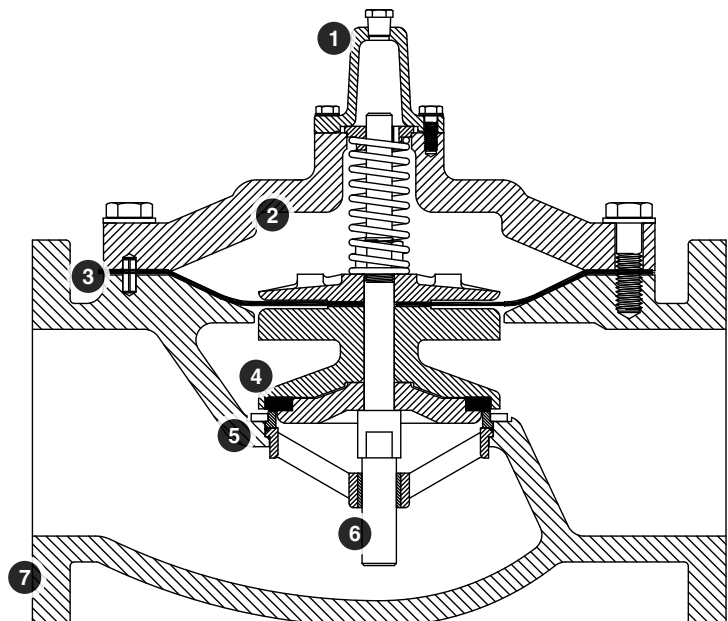

### Alternate Models



MS106-PG Angle



MS106-PG Threaded

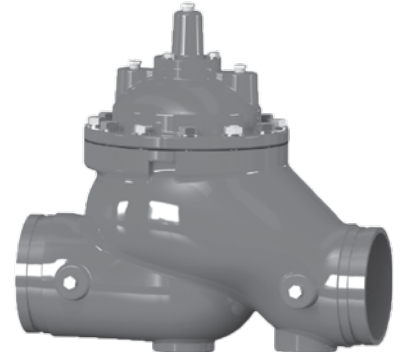

MS106-GE Globe

### Valve Sizes and Materials

#### Valve Styles

Available Styles	Ductile Iron			Stainless Steel	
	Threaded	Flanged	Grooved	Threaded	Flanges
Globe	1" - 3" (25-80mm)	1-1/2" - 36" (40-900mm)	2" - 8" (50-200mm)	1/2" - 2" (15-50mm)	1-1/2" - 6" (40-150mm)
Angle	1" - 3" (25-80mm)	2" - 12", 16" (50-300mm, 400mm)	-	-	-

#### Valve Components

Part	Description	Ductile Iron	
		Material	
		Standard	Optional
1	Valve body, Cover	65-45-12 ductile iron	-
2	Seat ring	316 stainless steel	-
3	Disc retainer	B16 brass / B62 bronze / A536 ductile iron	Stainless steel
4	Stem	316 stainless steel	-
5	Stem nut	B16 brass	316 stainless steel
6	Spring	316 stainless steel	-
7	Guide bushings	B16 brass or SAE 660 bronze	Stainless steel
8	Diaphragm	EPDM	BUNA-N / Vitron (limited sizes)
9	Resilient disc	EPDM	BUNA-N / Vitron (limited sizes)
10	Coating	HFE coating AKZO RAL 3000 fire red	(Consult factory)
11	Fasteners	18-8 stainless steel	316 stainless steel

**MODEL M106-GE/M206-GE  
GROOVED ENDS****M106-GE / M206-GE**

For use with grooved Iron Pipe Size (IPS) Pipe Coupling Products, grooved ends allows you to benefit from the simplicity and convenience of grooved end piping and fittings in an automatic control valve. There are a wide range of applications where grooved ends are relevant, but typical applications include municipal water, waste water, fire protection and plumbing.

**Grooved ends come in the following size ranges:**

- 2 in/50 mm – 8 in/200 mm

Standard cut groove specifications for steel and other IPS pipe will apply, unless otherwise specified

- Main valve body shall be complete with grooved ends.
- Standard cut groove specifications will be “steel and other IPS pipe” only unless otherwise specified.

**Features**

- Convenient system and equipment access for ease of alignment and installation
- Improved flexibility with expansion, contraction and deflection
- Seismic stress absorption
- Eliminated unions
- Grooved to ANSI/AWWA C606

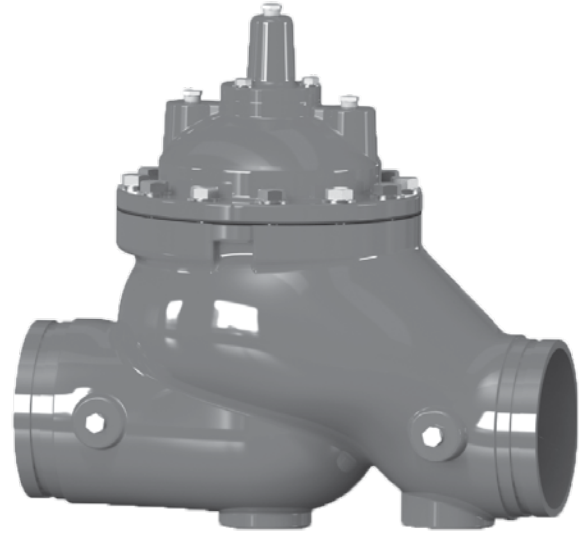
**MS106-GE Globe**

## FIRE PROTECTION PRODUCTS

### M106-EDV-A-10507A

Model M106 EDV-A-10507A Electric Solenoid control valve is based on the Model M106 PG-UL Deluge main valve.

The solenoid pilot provides on-off position operation. The solenoid either admits inlet pressure into the main valve operating chamber from the inlet of the main valve via a high capacity relay valve or releases pressure from the relay valve and therefore the main valve operating chamber. This either opens or closes the main valve. The pilot system is usually piped to discharge to drain (atmosphere).

The M106 EDV-A-10507A is available with the main valve closed when the solenoid is de-energized (NC-normally closed). This refers to the main valve, not the solenoid).

### Features

- UL listed to ANSI/UL 260
- Reliable diaphragm actuated
- Hydraulically operated design
- ANSI class 150, 300 flanges and grooved ends
- Stainless steel fasteners
- Heat fused red epoxy coating
- Available in globe style, 3 in/80mm - 8 in/200mm

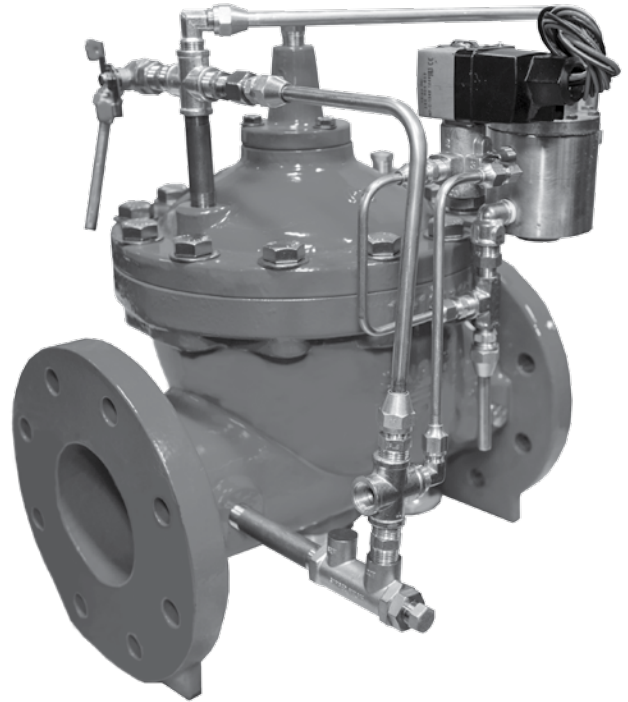

**MS106-EDV-A-10507A Globe**

### Standard materials for pilot system components

- ASTM B62 bronze or ASTM B16 brass
- AISI 303/316 stainless steel trim
- Buna-N/EPDM diaphragm and seals

*All valves have HFE coating AKZO RAL 3000 Fire Red (not intended for drinking water).*

### Schematic Drawing

1. Main Valve – Model M106-PG-UL-Deluge
2. Strainer
3. Fixed restriction
4. M82-PR-UL Pilot
5. Solenoid Valve – normally open
6. Manual Emergency Override – normal position closed

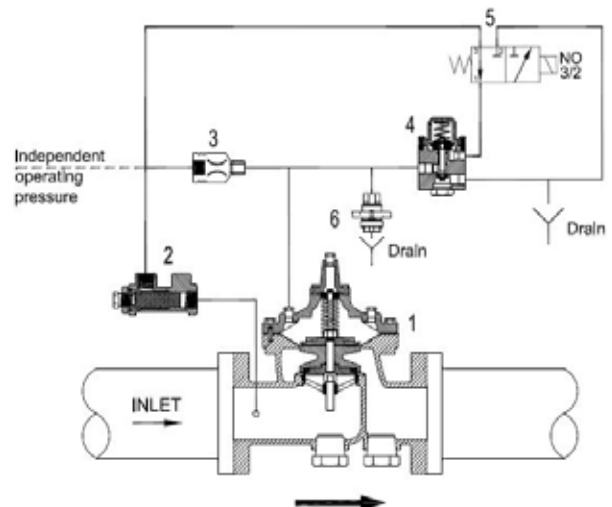

**Schematic A-10507A**

**MODEL M106-PDV-A-10508A  
PNEUMATICALLY OPERATED  
REMOTE CONTROL DELUGE VALVE****M106-PDV-A-10508A**

Model M106 PDV-A-10508A Pneumatically Operated Control valve is based on the Model M106 PG-UL Deluge main valve.

The high capacity relay valve provides on-off position operation. The high capacity relay valve, using an independent air supply, either admits inlet pressure into the main valve operating chamber from the inlet of the main valve or releases pressure from the operating chamber. The pilot system is usually piped to discharge to drain (atmosphere).

**Features**

- UL listed to ANSI/UL 260
- Reliable diaphragm actuated
- Hydraulically operated design
- ANSI class 150, 300 flanges and grooved ends
- Stainless steel fasteners
- Heat fused red epoxy coating
- Available in globe style, 3 in/80mm - 8 in/200mm

**Standard materials for pilot system components**

- ASTM B62 bronze or ASTM B16 brass
- AISI 303/316 stainless steel trim
- Buna-N/EPDM diaphragm and seals

*All valves have HFE coating AKZO RAL 3000 Fire Red (not intended for drinking water).*

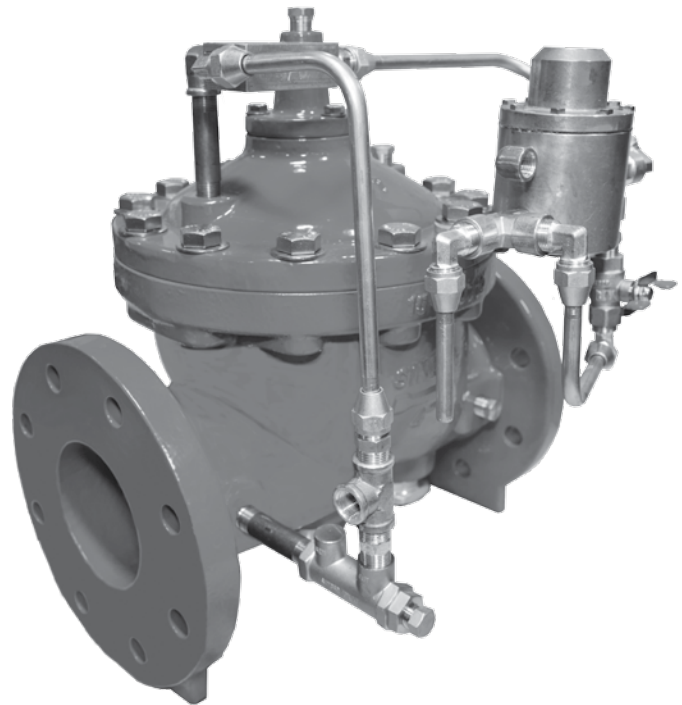

M106-PDV-A-10508A Globe

**Schematic Drawing**

1. Main Valve – Model M106-PG-UL-Deluge
2. Strainer
3. Ejector - MX141A
4. M82-PR-UL Pilot
5. Manual Emergency Override – normal position closed

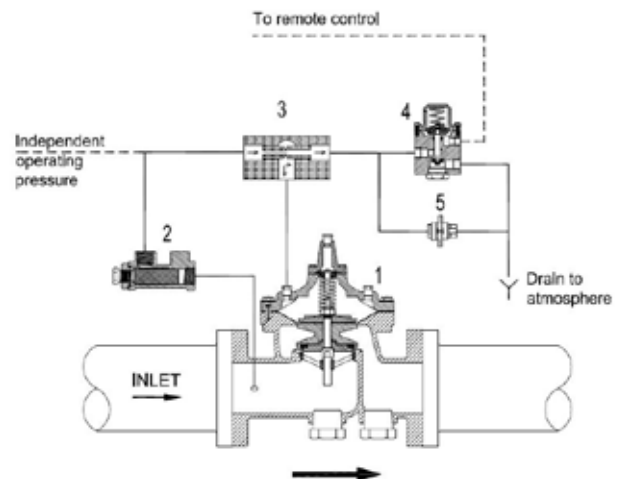

Schematic A-10508A



## FIRE PROTECTION PRODUCTS

### M106-EPDV-A-10506A

Model M106 EPDV-A-10506A Pneumatic/Electric Solenoid control valve is based on the Model M106 PG-UL Deluge main valve.

The solenoid pilot provides on-off position operation. The solenoid, using an independent air supply, either admits inlet pressure into the main valve operating chamber from the inlet of the main valve via a high capacity relay valve or releases pressure from the relay valve and therefore the main valve operating chamber. This either opens or closes the main valve. The pilot system is usually piped to discharge to drain (atmosphere).

The M106 EPDV-A-10506A is available with the main valve closed when the solenoid is de-energized (NC-normally closed. This refers to the main valve, not the solenoid).

### Features

- UL listed for fire extinguishing systems
- Reliable diaphragm actuated
- Hydraulically operated design
- ANSI class 150, 300 flanges and grooved ends
- Stainless steel fasteners
- Heat fused red epoxy coating
- Available in globe style, 3 in/80mm - 8 in/200mm

### Standard materials for pilot system components

- ASTM B62 bronze or ASTM B16 brass
- AISI 303/316 stainless steel trim
- BUNA-N/EPDM diaphragm and seals

*All valves have HFE coating AKZO RAL 3000 Fire Red (not intended for drinking water).*

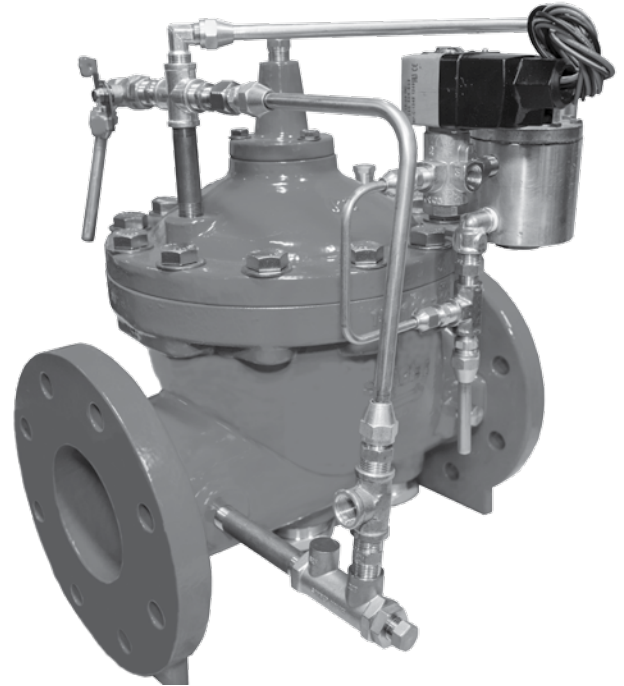

**MS106-EPDV-A-10508A Globe**

### Schematic Drawing

1. Main Valve – Model M106-PG-UL-Deluge
2. Strainer
3. Fixed Restriction
4. M82-PR-UL Pilot
5. Solenoid Valve – normally open
6. Manual Emergency Override – normal position closed

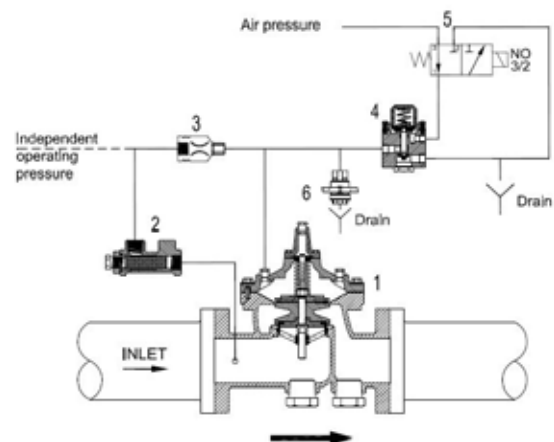

**Schematic A-10506A**

**MODEL M106-PG FULL PORT,  
SINGLE CHAMBER, HYDRAULICALLY  
OPERATED VALVE**



**Dimensions**

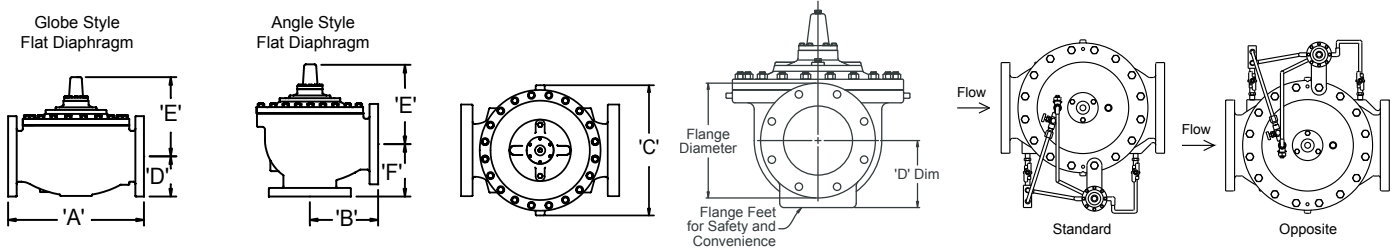

**ANSI Valve Data (US Units)**

Size	DWG	Standard	Flat Diaphragm System										
Inches	REF	ANSI	1/2 in	3/4 in	1 in	1-1/4 in	1-1/2 in	2 in	2-1/2 in	3 in	4 in	6 in	8 in
<b>Globe Dimensions</b>			<b>All figures shown in inches unless otherwise stated</b>										
Lay Length	A	FNPT	3.50	3.50	6.75	6.75	6.75	9.38	11.00	13.50	-	-	-
Centerline to Bottom	D	FNPT	1.20	1.20	2.50	2.50	2.50	2.75	3.38	3.68	-	-	-
Lay Length	A	150F	-	-	-	-	8.50	9.38	11.00	12.00	15.00	20.00	25.38
Centerline to Bottom	D	150F	-	-	-	-	2.75	3.00	3.50	3.75	4.60	5.60	7.63
Lay Length	A	300F	-	-	-	-	9.00	10.00	11.63	13.25	15.63	21.00	26.38
Centerline to Bottom	D	300F	-	-	-	-	3.25	3.25	3.75	4.13	5.09	6.34	7.88
<b>Angle Dimensions</b>													
Center Inlet to Discharge	B	FNPT	-	-	3.38	3.38	3.38	4.69	5.50	6.63	-	-	-
Center Discharge to Inlet	F	FNPT	-	-	3.00	3.00	3.00	3.25	4.00	4.63	-	-	-
Center Inlet to Discharge	B	150F	-	-	-	-	-	4.75	5.50	6.06	7.50	10.00	12.75
Center Discharge to Inlet	F	150F	-	-	-	-	-	3.25	4.00	4.06	5.00	6.00	8.00
Center Inlet to Discharge	B	300F	-	-	-	-	-	5.00	5.88	6.43	7.88	10.50	13.25
Center Discharge to Inlet	F	300F	-	-	-	-	-	3.50	4.31	4.43	5.31	6.50	8.50
<b>Common Dimensions (Globe &amp; Angle)</b>													
Width	C		3.00	3.00	4.88	4.88	6.13	6.5	8.19	9.25	10.88	16.75	21.63
Height (To Stem Cap) Globe	E		3.06	3.06	4.38	4.38	4.38	6.75	9.5	10.5	12.25	11.75	14.91
Height (To Stem Cap) Angle	E		-	-	4.38	4.38	4.38	4.75	7.71	10.5	12.25	11.75	14.91
Body Port Tapping		FNPT	1/4	1/4	3/8	3/8	3/8	3/8	3/8	3/8	3/8	3/8	1/2
Stem Cap Plug		MNPT	1/4	1/4	3/8	3/8	3/8	3/8	3/8	3/8	3/8	3/8	3/8
Cover Port Tapping		FNPT	-	-	3/8	3/8	3/8	3/8	3/8	3/8	3/8	1/2	1/2
Valve Stroke			1/4	1/4	1/2	1/2	1/2	9/16	15/16	1-1/8	1-7/16	1-11/16	2-7/8
Displaced Bonnet Volume (Gallons)			0.002	0.002	0.007	0.007	0.007	0.02	0.1	0.1	0.2	0.6	1.7
Approximate Shipping Weight (Lbs)			10	10	20	20	20	40	65	100	175	400	650
<b>Flow Capacities (USGPM) Globe &amp; Angle</b>													
C <sub>v</sub> - Globe					28	30	32	55	80	110	200	460	800
C <sub>v</sub> - Angle					24	24	26	63	90	135	230	535	950
Continuous (Globe)					49	93	125	210	300	460	800	1800	3100
Intermittent (Globe)					61	120	160	260	375	575	1000	2250	3875
Momentary (Globe)					110	170	250	470	670	1030	1800	4000	7000
<b>Maximum Pressure Ratings (Ductile Only)</b>													
PSIG <sup>1</sup>		FNPT	400	400	400	400	400	400	400	400	-	-	-
PSIG		150F	-	-	250	250	250	250	250	250	250	250	250
PSIG <sup>1</sup>		300F	-	-	400	400	400	400	400	400	400	400	400
<b>Maximum Temperature</b>													
Fahrenheit			180°	180°	180°	180°	180°	180°	180°	180°	180°	180°	180°

<sup>1</sup>Valves rated and stamped 400 psig as standard. Valves rated and stamped 600 psig on request.

### ANSI Valve Data (US and Metric Units)

Size	DWG	Standard	Rolling Diaphragm System			
			US Units		Metric Units	
Inches/mm	REF	ANSI	6 in	8 in	150 mm	200 mm
<b>Globe Dimensions</b>			inches		mm	
Lay Length	A	-	-	-	-	-
Centerline to Bottom	D	-	-	-	-	-
Lay Length	A	-	20.00	25.38	508	645
Centerline to Bottom	D	-	5.60	7.63	142	200
Lay Length	A	-	21.00	26.38	533	670
Centerline to Bottom	D	-	6.34	7.88	161	200
<b>Angle Dimensions</b>			inches		mm	
Center Inlet to Discharge	B	-	-	-	-	-
Center Discharge to Inlet	F	-	-	-	-	-
Center Inlet to Discharge	B	-	-	-	-	-
Center Discharge to Inlet	F	-	-	-	-	-
Center Inlet to Discharge	B	-	-	-	-	-
Center Discharge to Inlet	F	-	-	-	-	-
<b>Common Dimensions (Globe &amp; Angle)</b>			inches		mm	
Width	C	-	12.75	16.09	324	409
Height (To Stem Cap) Globe	E	-	15.43	20.19	392	513
Height (To Stem Cap) Angle	E	-	-	-	-	-
Body Port Tapping	FNPT	inch	3/8	1/2	3/8	1/2
Stem Cap Plug	MNPT	inch	3/8	3/8	3/8	3/8
Cover Port Tapping	FNPT	inch	1/2	1/2	1/2	1/2
Valve Stroke			1-11/16	2-7/8	43	73
Displaced Bonnet Volume			0.50 gal	1.00 gal	2 L	4 L
Approximate Shipping Weight			350 Lbs	650 Lbs	160 Kg	250 Kg
<b>Flow Capacities Globe &amp; Angle</b>			USGPM		L/s	
C <sub>v</sub> - Globe			460	800	110	190
C <sub>v</sub> - Angle			-	-	-	-
Continuous (Globe)			1800	3100	114	196
Intermittent (Globe)			2250	3875	142	244
Momentary (Globe)			4000	7000	252	442
<b>Maximum Pressure Ratings (Ductile Only)</b>			PSI		Bar	
		FNPT	-	-	-	-
		150F	250	250	17	17
		300F	400	400	27.6	27.6
<b>Maximum Temperature</b>			Fahrenheit		Celcius	
			180°	180°	82°	82°

**MODEL M106-PG FULL PORT,  
SINGLE CHAMBER, HYDRAULICALLY  
OPERATED VALVE**



**Dimensions**

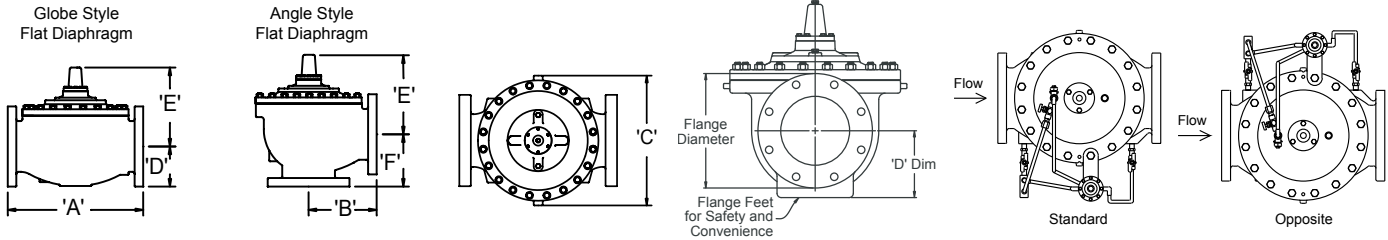

**ANSI Valve Data (Metric Units)**

Size	DWG	Standard	Flat Diaphragm System										
			15 mm	20 mm	25 mm	32 mm	40 mm	50 mm	65 mm	80 mm	100 mm	150 mm	200 mm
mm	REF	ISO	All figures show in mm unless otherwise stated										
<b>Globe Dimensions</b>			All figures show in mm unless otherwise stated										
Lay Length	A	-	89	89	171	171	171	238	279	343	-	-	-
Centerline to Bottom	D	-	31	31	64	64	64	70	86	93	-	-	-
Lay Length	A	-	-	-	-	-	229	238	279	318	381	508	645
Centerline to Bottom	D	-	-	-	-	-	83	76	89	100	117	142	200
Lay Length	A	-	-	-	-	-	229	238	279	318	397	533	670
Centerline to Bottom	D	-	-	-	-	-	83	76	89	100	129	161	200
<b>Angle Dimensions</b>													
Center Inlet to Discharge	B	-	-	-	86	86	86	119	140	168	-	-	-
Center Discharge to Inlet	F	-	-	-	76	76	76	83	102	118	-	-	-
Center Inlet to Discharge	B	-	-	-	-	-	-	121	140	163	191	254	324
Center Discharge to Inlet	F	-	-	-	-	-	-	83	102	113	127	152	203
Center Inlet to Discharge	B	-	-	-	-	-	-	121	140	163	200	267	337
Center Discharge to Inlet	F	-	-	-	-	-	-	83	102	113	135	165	216
<b>Common Dimensions (Globe &amp; Angle)</b>													
Width	C	-	76	76	124	124	156	152	208	235	276	425	549
Height (To Stem Cap) Globe	E	-	78	78	111	111	111	121	191	203	232	298	379
Height (To Stem Cap) Angle	E	-	-	-	111	111	111	121	191	203	232	298	379
Body Port Tapping	FNPT	Inches	1/4	1/4	3/8	3/8	3/8	3/8	3/8	3/8	3/8	3/8	1/2
Stem Cap Plug	MNPT	Inches	1/4	1/4	3/8	3/8	3/8	3/8	3/8	3/8	3/8	3/8	3/8
Cover Port Tapping	FNPT	Inches	-	-	3/8	3/8	3/8	3/8	3/8	3/8	3/8	1/2	1/2
Valve Stroke		mm	6.4	6.4	13	13	13	14	25	29	37	43	73
Displaced Bonnet Volume (Litres)			0.01	0.01	0.03	0.03	0.03	0.1	0.3	0.3	0.8	2.1	6.3
Approximate Shipping Weight (Kilograms)			5	5	9	9	9	18	29	45	79	181	295
<b>Flow Capacities (L/s) Globe &amp; Angle</b>													
K <sub>v</sub> - Globe			-	-	6.6	7.1	7.6	13	19	26	47	110	190
K <sub>v</sub> - Angle			-	-	5.7	5.7	6.2	15	21	32	55	123	225
Continuous (Globe)			-	-	3	6	8	13	19	29	50	114	196
Intermittent (Globe)			-	-	4	8	10	16	24	36	63	142	244
Momentary (Globe)			-	-	7	11	16	30	42	65	114	252	442
<b>Maximum Pressure Ratings (Ductile Only)</b>													
Barg <sup>1</sup>		-	27.6	27.6	27.6	27.6	27.6	27.6	27.6	27.6	-	-	-
Barg		-	-	-	-	-	16	16	16	16	16	16	16
Barg <sup>1</sup>		-	-	-	-	-	25	25	25	25	25	25	25
<b>Maximum Temperature</b>													
Celcius			82°	82°	82°	82°	82°	82°	82°	82°	82°	82°	82°

<sup>1</sup>Valves rated and stamped 27.6 barg as standard. Valves rated and stamped 41 barg on request  
<sup>\*</sup>UL/FM Relief rated to 20.7 barg

## FIRE PROTECTION PRODUCTS

### Dimensions

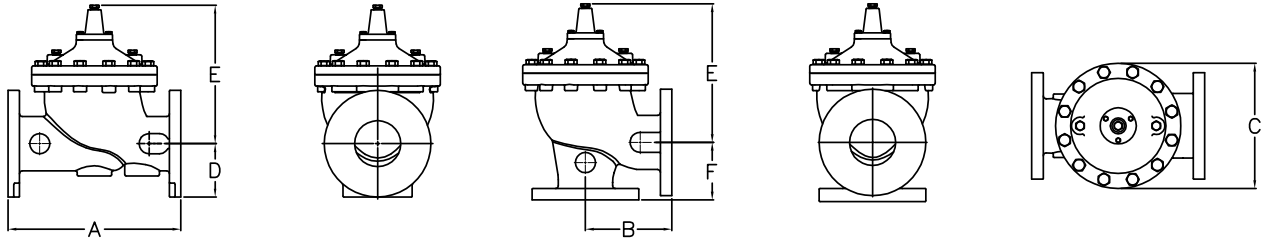

**ANSI Valve Data (US Units)**

Size	DWG	Standard	Flat Diaphragm System					
Inches	REF	ANSI	2 in	2-1/2 in	3 in	4 in	6 in	8 in
<b>Globe Dimensions</b>			<b>All figures show in inches unless otherwise stated</b>					
Lay Length	A	FNPT	9.38	11.00	13.50	-	-	-
Centerline to Bottom	D	FNPT	2.75	3.38	3.68	-	-	-
Lay Length	A	150F	9.38	11.00	12.00	15.00	20.00	25.38
Centerline to Bottom	D	150F	3.00	3.50	3.75	4.60	5.60	7.63
Lay Length	A	300F	10.00	11.63	13.25	15.63	21.00	26.38
Centerline to Bottom	D	300F	3.25	3.75	4.13	5.09	6.34	7.88
<b>Angle Dimensions</b>								
Center Inlet to Discharge	B	FNPT	4.69	5.50	6.63	-	-	-
Center Discharge to Inlet	F	FNPT	3.25	4.00	4.63	-	-	-
Center Inlet to Discharge	B	150F	4.75	5.50	6.06	7.50	10.00	12.75
Center Discharge to Inlet	F	150F	3.25	4.00	4.06	5.00	6.00	8.00
Center Inlet to Discharge	B	300F	5.00	5.88	6.43	7.88	10.50	13.25
Center Discharge to Inlet	F	300F	3.50	4.31	4.43	5.31	6.50	8.50
<b>Common Dimensions (Globe &amp; Angle)</b>								
Width	C	-	6.50	8.19	9.25	10.88	16.75	21.63
Height (To Stem Cap) Globe	E	-	4.75	7.50	8.00	9.15	11.75	14.91
Height (To Stem Cap) Angle	E	-	4.75	7.50	8.00	9.15	11.75	14.91
Body Port Tapping		FNPT	3/8	3/8	3/8	3/8	3/8	1/2
Stem Cap Plug		MNPT	3/8	3/8	3/8	3/8	3/8	3/8
Cover Port Tapping		FNPT	3/8	3/8	3/8	3/8	1/2	1/2
Valve Stroke			9/16	15/16	1-1/8	1-7/16	1-11/16	2-7/8
Displaced Bonnet Volume (Gallons)			0.02	0.1	0.1	0.2	0.6	1.7
Approximate Shipping Weight (Lbs)			40	65	100	175	400	650
<b>Flow Capacities (USGPM) Globe &amp; Angle</b>								
C <sub>v</sub> - Globe			55	80	110	200	460	800
C <sub>v</sub> - Angle			63	90	135	230	535	950
Continuous (Globe)			210	300	460	800	1800	3100
Intermittent (Globe)			260	375	575	1000	2250	3875
Momentary (Globe)			470	670	1030	1800	4000	7000
<b>Maximum Pressure Ratings (Ductile Only)</b>								
PSIG <sup>1</sup>		FNPT	400	400	400	-	-	-
PSIG		150F	250	250	250	250	250	250
PSIG <sup>1</sup>		300F	400*	400*	400*	400*	400*	400*
<b>Maximum Temperature</b>								
Fahrenheit			180°	180°	180°	180°	180°	180°

<sup>1</sup>Valves rated and stamped 400 psig as standard. Valves rated and stamped 600 psig on request.

\*UL/FM Relief rated to 300 psig

**MODEL M106-PG - UL/FM RELIEF & ULC REDUCING ONLY FULL PORT, SINGLE CHAMBER, HYDRAULICALLY OPERATED VALVE**



**Dimensions**

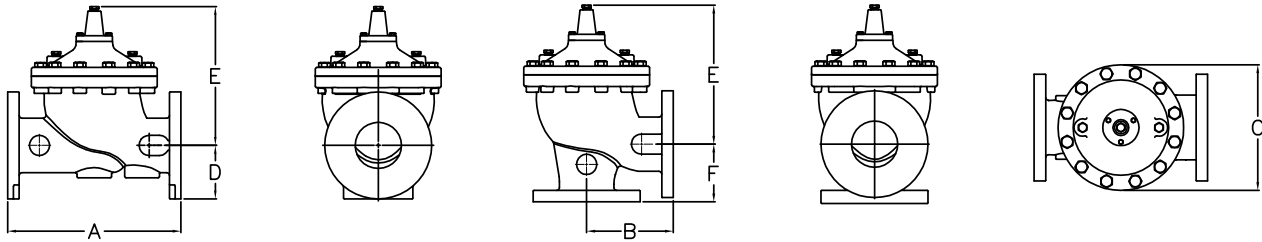

**ANSI Valve Data (Metric Units)**

Size	DWG	Standard	Flat Diaphragm System					
mm	REF	ANSI	50 mm	65 mm	80 mm	100 mm	150 mm	200 mm
<b>Globe Dimensions</b>			All figures show in mm unless otherwise stated					
Lay Length	A	FNPT	238	279	343	-	-	-
Centerline to Bottom	D	FNPT	70	86	93	-	-	-
Lay Length	A	150F	238	279	305	381	508	645
Centerline to Bottom	D	150F	76	89	95	117	142	200
Lay Length	A	300F	254	295	337	397	533	670
Centerline to Bottom	D	300F	83	95	105	129	161	200
<b>Angle Dimensions</b>								
Center Inlet to Discharge	B	FNPT	119	140	168	-	-	-
Center Discharge to Inlet	F	FNPT	83	102	118	-	-	-
Center Inlet to Discharge	B	150F	121	140	154	191	254	324
Center Discharge to Inlet	F	150F	83	102	103	127	152	203
Center Inlet to Discharge	B	300F	127	149	163	200	267	337
Center Discharge to Inlet	F	300F	89	109	113	135	165	216
<b>Common Dimensions (Globe &amp; Angle)</b>								
Width	C	-	165	208	235	276	425	549
Height (to stem cap) Globe	E	-	121	191	203	232	298	379
Height (to stem cap) Angle	E	-	121	191	203	232	298	379
Body Port Tapping	FNPT	in	3/8	3/8	3/8	3/8	3/8	1/2
Stem Cap Plug	MNPT	in	3/8	3/8	3/8	3/8	3/8	3/8
Cover Port Tapping	FNPT	in	3/8	3/8	3/8	3/8	1/2	1/2
Valve Stroke		mm	14	25	29	37	43	73
Displaced Bonnet Volume (Litres)			0.1	0.3	0.3	0.8	2.1	6.3
Approximate Shipping Weight (Kilograms)			18	29	45	79	181	295
<b>Flow Capacities (L/s) Globe &amp; Angle</b>								
Kv - Globe			13	19	26	47	110	190
Kv - Angle			15	21	32	55	127	225
Continuous (Globe)			13	19	29	50	114	196
Intermittent (Globe)			16	24	36	63	142	244
Momentary (Globe)			30	42	65	114	252	442
<b>Maximum Pressure Ratings (Ductile Only)</b>								
Barg <sup>1</sup>		FNPT	27.6	27.6	27.6	-	-	-
Barg		150F	17	17	17	17	17	17
Barg <sup>1</sup>		300F	27.6*	27.6*	27.6*	27.6*	27.6*	27.6*
<b>Maximum Temperature</b>								
Celcius			82°	82°	82°	82°	82°	82°

<sup>1</sup>Valves rated and stamped 27.6 barg as standard. Valves rated and stamped 41 barg on request

\*UL/FM Relief rated to 20.7 barg

## FIRE PROTECTION PRODUCTS

### Valve Data (US Units)

	DWG	Standard	Flat Diaphragm System				Single Rolling Diaphragm System	
Inches	REF	Grooved Ends	2 in	2-1/2 in	3 in	4 in	6 in	8 in
<b>Globe Dimensions</b>			All figures shown in inches unless otherwise stated					
Lay Length	A	-	9.00	11.00	12.50	15.00	20.00	25.37
Centerline to Bottom	D	-	1.31	1.54	2.25	2.81	4.00	5.00
<b>Common Dimensions (Globe)</b>								
Width	C	-	5.87	7.75	9.25	10.88	12.13	17.16
Height (To Stem Cap) Globe	E	-	6.35	9.32	10.06	11.74	15.01	19.70
Body Port Tapping		FNPT	3/8	3/8	3/8	3/8	3/8	1/2
Stem Cap Plug		MNPT	3/8	3/8	3/8	3/8	3/8	3/8
Cover Port Tapping		FNPT	3/8	3/8	3/8	3/8	3/8	1/2
Valve Stroke			9/16	15/16	1 1/8	1 7/16	1 11/16	2 7/8
Displaced Bonnet Volume (Gallons)			0.02	0.07	0.1	0.2	0.6	1.7
Approximate Shipping Weight (Lbs)			28	49	80	148	350	590
<b>Flow Capacities (USGPM) Globe</b>								
C <sub>v</sub>			55	80	110	200	460	800
Continuous (Globe)			210	300	460	800	1800	3100
Intermittent (Globe)			260	375	575	1000	2250	3875
Momentary (Globe)			470	670	1030	1800	4000	7000
<b>Maximum Pressure Ratings (Ductile Only)</b>								
PSIG		Grooved Ends	400	400	400	400	400	400
<b>Maximum Temperature</b>								
Fahrenheit			180°	180°	180°	180°	180°	180°

### Valve Data (Metric Units)

	DWG	Standard	Flat Diaphragm System				Single Rolling Diaphragm System	
MM	REF	Grooved Ends	50 mm	65 mm	80 mm	100 mm	150 mm	200 mm
<b>Globe Dimensions</b>			All figures shown in millimeters unless otherwise stated					
Lay Length	A	-	229	279	318	381	508	645
Centerline to Bottom	D	-	33	39	57	71	102	127
<b>Common Dimensions (Globe)</b>								
Width	C	-	149	197	235	276	308	436
Height (To Stem Cap) Globe	E	-	161	237	256	298	381	500
Body Port Tapping	FNPT	Inches	3/8	3/8	3/8	3/8	3/8	1/2
Stem Cap Plug	MNPT	Inches	3/8	3/8	3/8	3/8	3/8	3/8
Cover Port Tapping	FNPT	Inches	3/8	3/8	3/8	3/8	3/8	1/2
Valve Stroke	-	mm	14	25	29	37	43	73
Displaced Bonnet Volume (Litres)			0.1	0.3	0.3	0.8	2.1	6.3
Approximate Shipping Weight (Kilograms)			13	22.2	37	67	160	268
<b>Flow Capacities (L/s) Globe</b>								
K <sub>v</sub> (Globe)			13	19	26	47	110	190
Continuous (Globe)			13	19	29	50	114	196
Intermittent (Globe)			16	24	36	63	142	244
Momentary (Globe)			30	42	65	114	252	442
<b>Maximum Pressure Ratings (Ductile Only)</b>								
Barg		Grooved Ends	27.6	27.6	27.6	27.6	27.6	27.6
<b>Maximum Temperature</b>								
Celcius			82°	82°	82°	82°	82°	82°

SECTION  
**G-1**

Rev. 6-17

Shaded area indicates change

**MODEL M106-EDV-A-10507A  
ELECTRONICALLY OPERATED  
DELUGE VALVE**



**UL / FM**

**FIRE PROTECTION PRODUCTS**

**Dimensions**

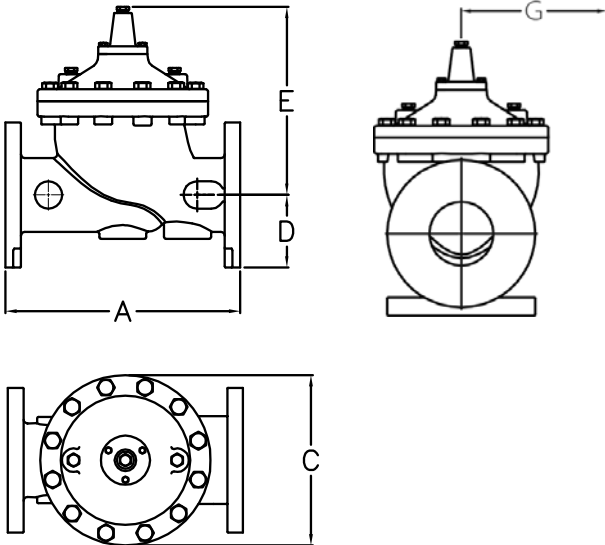

Deluge Valves - UL Listed	
Valve Size	Max Pressure
3 in/80mm - 8 in / 200mm	400 psig/27.6 barg

Weights (Lbs)	3"	4"	6"	8"
150# Flanged	84	128	183	372
300# Flanged	88	140	224	425

Weights (Kg)	80 mm	100 mm	150 mm	200 mm
150# Flanged	38	58	83	169
300# Flanged	40	63.5	102	193

Clearance for pilot system

**ANSI Valve Data (US Units)**

Size	DWG	US Units				
Inches	REF	ANSI	3 in	4 in	6 in	8 in
<b>Globe Dimensions</b> <i>All figures shown in mm unless otherwise indicated</i>						
Lay Length	A	150F	12.00	15.00	20.00	25.38
Centerline to Bottom	D	150F	3.75	4.60	5.60	7.63
Lay Length	A	300F	.25	15.63	21.00	26.38
Centerline to Bottom	D	300F	4.13	5.09	6.34	7.88
Width	C	-	9.25	10.88	12.75	16.09
Height (To Stem Cap)	E	-	8.00	9.15	15.43	20.19
Pilot System Clearance	G	-	9.84	10.62	11.81	13.38
Body Port Tapping		FNPT	3/8	3/8	3/8	1/2
Stem Cap Plug		MNPT	3/8	3/8	3/8	3/8
Cover Port Tapping		FNPT	3/8	3/8	1/2	1/2
Valve Stroke			1-1/8	1-7/16	1-11/16	2-7/8
Displaced Bonnet Volume (Gallons/Litres)			0.1	0.2	0.50	1.00
<b>Flow Capacities USGPM</b>						
C <sub>v</sub>			110	200	460	800
Continuous			460	800	1800	3100
Intermittent			575	1000	2250	3875
Momentary			1030	1800	4000	7000
<b>Maximum Temperature</b>						
Fahrenheit/Celsius			180°	180°	180°	180°

Metric Units			
80 mm	100 mm	150 mm	200 mm
<i>All figures shown in mm unless otherwise indicated</i>			
305	381	508	645
95	117	142	200
337	397	533	670
105	129	161	200
235	276	324	409
203	232	392	513
250	270	300	340
3/8	3/8	3/8	1/2
3/8	3/8	3/8	3/8
3/8	3/8	1/2	1/2
29	37	43	73
0.3	0.8	2	4
<b>L/S</b>			
26	47	110	190
29	50	114	196
36	63	142	244
65	114	252	442
82°	82°	82°	82°



**ANSI Valve Data (US Units)**

Size	DWG	US Units				
Inches	REF	ANSI	3 in	4 in	6 in	8 in
<b>Globe Dimensions</b>		<i>All figures shown in mm unless otherwise indicated</i>				
Lay Length	A	150F	12.00	15.00	20.00	25.38
Centerline to Bottom	D	150F	3.75	4.60	5.60	7.63
Lay Length	A	300F	.25	15.63	21.00	26.38
Centerline to Bottom	D	300F	4.13	5.09	6.34	7.88
Width	C	-	9.25	10.88	12.75	16.09
Height (To Stem Cap)	E	-	8.00	9.15	15.43	20.19
Pilot System Clearance	G	-	9.84	10.62	11.81	13.38
Body Port Tapping		FNPT	3/8	3/8	3/8	1/2
Stem Cap Plug		MNPT	3/8	3/8	3/8	3/8
Cover Port Tapping		FNPT	3/8	3/8	1/2	1/2
Valve Stroke			1-1/8	1-7/16	1-11/16	2-7/8
Displaced Bonnet Volume (Gallons/Litres )			0.1	0.2	0.50	1.00
<b>Flow Capacities USGPM</b>						
C <sub>v</sub>			110	200	460	800
Continuous			460	800	1800	3100
Intermittent			575	1000	2250	3875
Momentary			1030	1800	4000	7000
<b>Maximum Temperature</b>						
Fahrenheit/Celsius			180°	180°	180°	180°

Metric Units			
80 mm	100 mm	150 mm	200 mm
<i>All figures shown in mm unless otherwise indicated</i>			
305	381	508	645
95	117	142	200
337	397	533	670
105	129	161	200
235	276	324	409
203	232	392	513
250	270	300	340
3/8	3/8	3/8	1/2
3/8	3/8	3/8	3/8
3/8	3/8	1/2	1/2
29	37	43	73
0.3	0.8	2	4
<b>L/S</b>			
26	47	110	190
29	50	114	196
36	63	142	244
65	114	252	442
82°	82°	82°	82°

**MODEL M106-PDV-A-10508A  
PNEUMATICALLY OPERATED  
REMOTE CONTROL DELUGE VALVE**



**ANSI Valve Data (US Units)**

Size	DWG	US Units				
Inches	REF	ANSI	3 in	4 in	6 in	8 in
<b>Globe Dimensions</b>		<i>All figures shown in mm unless otherwise indicated</i>				
Lay Length	A	150F	12.00	15.00	20.00	25.38
Centerline to Bottom	D	150F	3.75	4.60	5.60	7.63
Lay Length	A	300F	.25	15.63	21.00	26.38
Centerline to Bottom	D	300F	4.13	5.09	6.34	7.88
Width	C	-	9.25	10.88	12.75	16.09
Height (To Stem Cap)	E	-	8.00	9.15	15.43	20.19
Pilot System Clearance	G	-	9.84	10.62	11.81	13.38
Body Port Tapping		FNPT	3/8	3/8	3/8	1/2
Stem Cap Plug		MNPT	3/8	3/8	3/8	3/8
Cover Port Tapping		FNPT	3/8	3/8	1/2	1/2
Valve Stroke			1-1/8	1-7/16	1-11/16	2-7/8
Displaced Bonnet Volume (Gallons/Litres )			0.1	0.2	0.50	1.00
<b>Flow Capacities USGPM</b>						
C <sub>v</sub>			110	200	460	800
Continuous			460	800	1800	3100
Intermittent			575	1000	2250	3875
Momentary			1030	1800	4000	7000
<b>Maximum Temperature</b>						
Fahrenheit/Celsius			180°	180°	180°	180°

Metric Units			
80 mm	100 mm	150 mm	200 mm
<i>All figures shown in mm unless otherwise indicated</i>			
305	381	508	645
95	117	142	200
337	397	533	670
105	129	161	200
235	276	324	409
203	232	392	513
250	270	300	340
3/8	3/8	3/8	1/2
3/8	3/8	3/8	3/8
3/8	3/8	1/2	1/2
29	37	43	73
0.3	0.8	2	4
<b>L/S</b>			
26	47	110	190
29	50	114	196
36	63	142	244
65	114	252	442
82°	82°	82°	82°

## FIRE PROTECTION PRODUCTS

### Valve Data (US Units)

Inches	DWG	Standard	Single Rolling Diaphragm System			
	REF	Grooved Ends	3 in	4 in	6 in	8 in
<b>Globe Dimensions</b>			<b>All figures shown in inches unless otherwise stated</b>			
Lay Length	A	-	12.50	15.00	20.00	25.37
Centerline to Bottom	D	-	2.25	2.81	4.00	5.00
<b>Common Dimensions (Globe)</b>						
Width	C	-	9.25	10.88	12.13	17.16
Height (To Stem Cap) Globe	E	-	10.06	11.74	15.01	19.70
Body Port Tapping		FNPT	3/8	3/8	3/8	1/2
Stem Cap Plug		MNPT	3/8	3/8	3/8	3/8
Cover Port Tapping		FNPT	3/8	3/8	3/8	1/2
Valve Stroke			1 1/8	1 7/16	1 11/16	2 7/8
Displaced Bonnet Volume (Gallons)			0.1	0.2	0.6	1.7
Approximate Shipping Weight (Lbs)			80	148	350	590
<b>Flow Capacities (USGPM) Globe</b>						
C <sub>v</sub>			110	200	460	800
Continuous (Globe)			460	800	1800	3100
Intermittent (Globe)			575	1000	2250	3875
Momentary (Globe)			1030	1800	4000	7000
<b>Maximum Pressure Ratings (Ductile Only)</b>						
PSIG		Grooved Ends	400	400	400	400
<b>Maximum Temperature</b>						
Fahrenheit			180°	180°	180°	180°

### Valve Data (Metric Units)

MM	DWG	Standard	Single Rolling Diaphragm System			
	REF	Grooved Ends	80 mm	100 mm	150 mm	200 mm
<b>Globe Dimensions</b>			<b>All figures shown in millimeters unless otherwise stated</b>			
Lay Length	A	-	318	381	508	645
Centerline to Bottom	D	-	57	71	102	127
<b>Common Dimensions (Globe)</b>						
Width	C	-	235	276	308	436
Height (To Stem Cap) Globe	E	-	256	298	381	500
Body Port Tapping	FNPT	Inches	3/8	3/8	3/8	1/2
Stem Cap Plug	MNPT	Inches	3/8	3/8	3/8	3/8
Cover Port Tapping	FNPT	Inches	3/8	3/8	3/8	1/2
Valve Stroke		mm	29	37	43	73
Displaced Bonnet Volume (Litres)			0.3	0.8	2.1	6.3
Approximate Shipping Weight (Kilograms)			37	67	160	268
<b>Flow Capacities (L/s) Globe</b>						
K <sub>v</sub> (Globe)			26	47	110	190
Continuous (Globe)			29	50	114	196
Intermittent (Globe)			36	63	142	244
Momentary (Globe)			65	114	252	442
<b>Maximum Pressure Ratings (Ductile Only)</b>						
Barg		Grooved Ends	27.6	27.6	27.6	27.6
<b>Maximum Temperature</b>						
Celcius			82°	82°	82°	82°

SECTION

**G-1**

Rev. 6-17

Shaded area indicates change

**MUELLER®  
AUTOMATIC CONTROL VALVES**



**UL / FM**

**FIRE PROTECTION PRODUCTS**



**Reliable Connections™**

[www.muellercompany.com](http://www.muellercompany.com) • [moreinfo@muellercompany.com](mailto:moreinfo@muellercompany.com)