

Digital Physician Scales

Waist Level



Model 150-10-6

Standard Features

- Motiontrap™ (movement compensation technology)
- Large LCD display
- Six AA alkaline batteries included
- Low-battery indicator/automatic power-off
- BMI (body mass index) function
- Hold function
- Unit of measure: lb only, kg only, lb/kg
- EHR capable
- Integrated wheels for portability ease

Specifications

Capacity:

550 lb x 0.2 lb (250 kg x 0.1 kg)

Platform Dimensions:

(W x L x H) 14.5 x 14.5 x 3 in

Power:

9 VDC, provided six AA batteries (included) or AC adaptor (optional)

Battery Type:

Six AA alkaline

Battery Use:

25 hours, continuous use with batteries

Approvals:

c-Met, E113986

Warranty:

Two-year limited warranty

Part Number/Price

Part #	Model	Capacity	Est. Weight	Price
161786	150-10-6	550 lb x 0.2 lb (250 kg x 0.1 kg), with USB	26 lb	\$485.00
161819	150-10-6BT	550 lb x 0.2 lb (250 kg x 0.1 kg), with USB and Bluetooth®	26 lb	\$572.00



Options/Accessories

Part #	Description	Price
115655	9 VDC adaptor, 120 V/230 V auto switching †, c-Met, medical grade power supply	\$32.00
133077	9 VDC adaptor, 120 V/230 V auto switching †	\$15.00
102508	9 VDC adaptor, 230 V ††	\$20.00
81076	Epson TM-U220 tape printer	\$420.00
186830	Printer cable, 25-pin D-sub male to RJ45, 6 ft	\$65.00



† NEMA 1-15 Plug

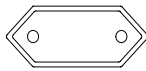

†† CEE 7/16 Plug

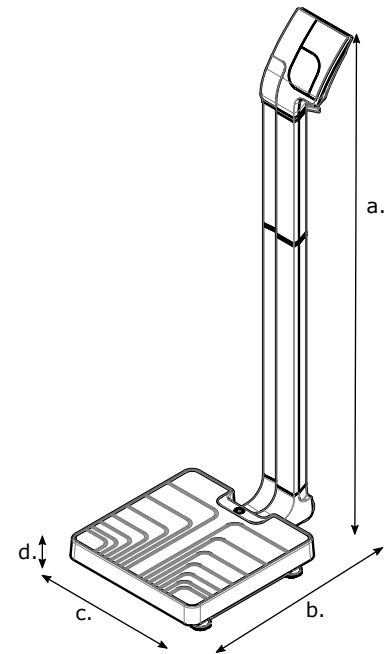

Dimensions			
A	48.4 in (123 cm)	C	14.7 in (37.5 cm)
B	22.4 in (57 cm)	D	3.0 in (7.8 cm)