

Specifications:

Conveyor Widths:

18 in to 72 in

Capacity:

Up to 10,000 tons per hour

Belt Speed:

Up to 1,200 feet per minute

Accuracy Guidelines:

Single-two idler system: 0.5%-1% total error

Three-four idler system: <0.5% total error

System Accuracy:

Guidelines assume clean belt with automatic tensioning system. Accuracy guidelines are typical. System accuracy may vary depending on environmental influences.



*Note: Idler not included.
Customer is responsible for
mounting idler to weigh frame.*

Applications

- Mining, quarries, bulk material blending, process control, utilities, truck/barge/rail loading and retrofit

Part Number/Price

Part #	Description	Est. Belt Width	Capacity	Price
Mild Steel Weigh Frames				
95205	20 in weigh frame	14 in	500 lb	\$1,995.00
95206	22 in weigh frame	16 in	500 lb	\$1,995.00
94968	24 in weigh frame	18 in	500 lb	\$1,995.00
95207	26 in weigh frame	20 in	500 lb	\$1,995.00
95208	30 in weigh frame	24 in	500 lb	\$1,995.00
95209	36 in weigh frame	30 in	500 lb	\$1,995.00
95210	42 in weigh frame	36 in	500 lb	\$1,995.00
95211	48 in weigh frame	42 in	500 lb	\$1,995.00
95212	54 in weigh frame	48 in	500 lb	\$1,995.00
96717	60 in weigh frame	54 in	1,000 lb	\$1,995.00
96718	66 in weigh frame	60 in	1,000 lb	\$1,995.00
96719	72 in weigh frame	66 in	1,000 lb	\$1,995.00
Consult	Light-capacity weigh frames			2,695.00
Stainless Steel Weigh Frames				
110837	20 in weigh frame	14 in	500 lb	\$2,895.00
110838	22 in weigh frame	16 in	500 lb	\$2,895.00
110839	24 in weigh frame	18 in	500 lb	\$2,895.00
110840	26 in weigh frame	20 in	500 lb	\$2,895.00
105246	30 in weigh frame	24 in	500 lb	\$2,895.00
110841	36 in weigh frame	30 in	500 lb	\$2,895.00
110842	42 in weigh frame	36 in	500 lb	\$2,895.00
110843	48 in weigh frame	42 in	500 lb	\$2,895.00
110844	54 in weigh frame	48 in	500 lb	\$2,895.00
110845	60 in weigh frame	54 in	500 lb	\$2,895.00
110846	66 in weigh frame	60 in	500 lb	\$2,895.00
110847	72 in weigh frame	66 in	500 lb	\$2,895.00
Consult	Light-capacity weigh frames			3,895.00
Weigh Frame Accessories				
97413	Shim, plastic 1/16 in thick			\$0.25
97414	Shim, plastic 1/8 in thick			\$0.30
97415	Shim, plastic 1/4 in thick			\$0.50
97416	Kit, shim 50 each 1/16 in, 1/8 in and 1/4 in thick			\$50.00
69203	Primer, light gray touch-up			\$20.00
66953	Paint, red touch-up			\$25.00

Please complete the Belt Scale Application on page 177 to obtain a quote

BCi

In-Motion Belt Scale System

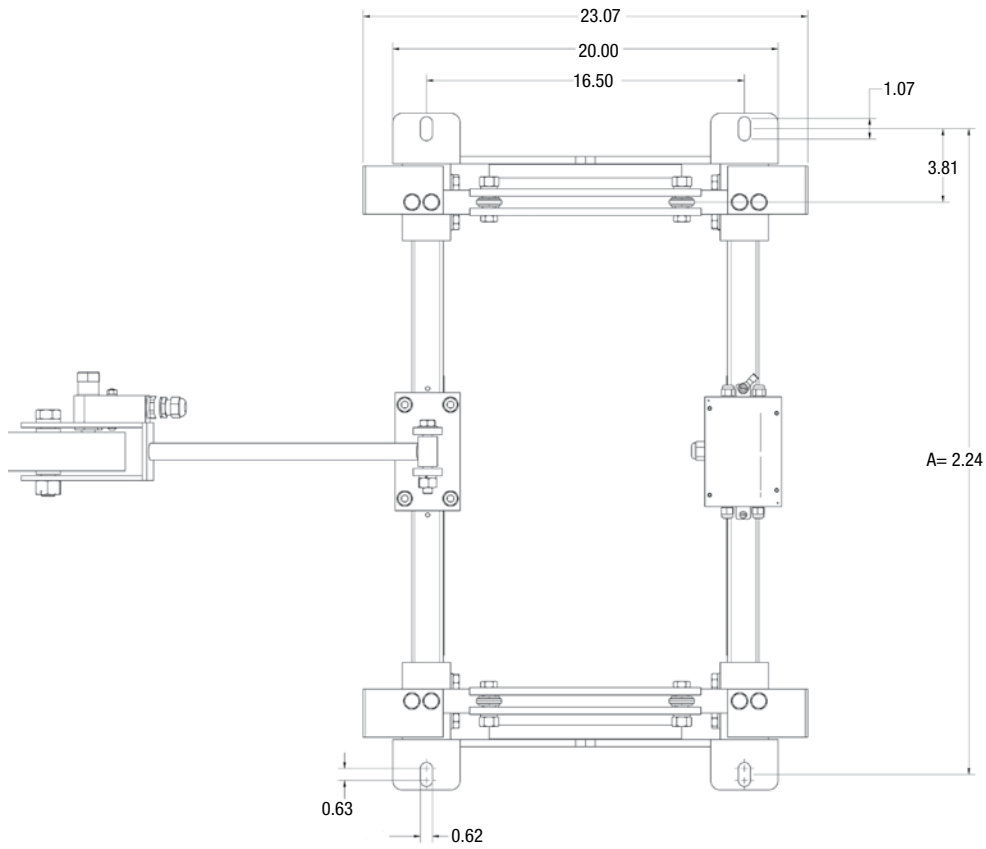
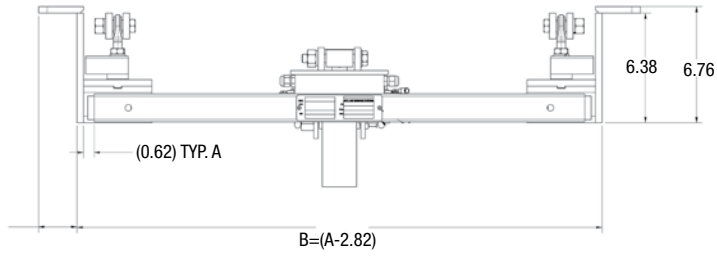

Note: Cables on drawings removed for clarity. Idler mounting hardware is not included in weigh frame, see idler mounting bolts above.