

One Person Loading

O.P.L. Feeder™

CHICAGO®



ULTRA COMPACT FEEDER

Built-in spreader/feeder with small piece bypass

O.P.L. is a compact, fast and ergonomically correct built-in spreader/feeder that lives up to the Chicago name for serious flatwork finishers. One that keeps up with the speed and power of Chicago's Tri-Star and CrosStar Ironer/Folder Series, as well as Chicago's complete line of mid-range and Imperial Ironers.

O.P.L. is the first built-in compact feeder designed for the larger sheets and production quantity demands of today's labor, efficiency and quality-conscious market.

O.P.L.

Dimensions and Utilities

NOTE:

1. Specifications subject to change without notice. Consult factory for certified construction floorplan.
2. Millimeter dimensions are in [].
3. All dimensions are +/- 1/2".
4. Utility connections are located as shown.

NOTE: Consult factory for pricing, availability, height and floorspace requirements for addition to existing ironers.

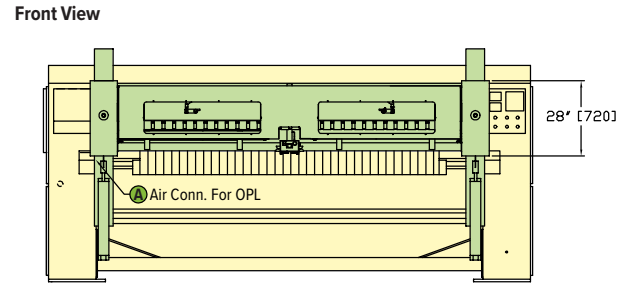
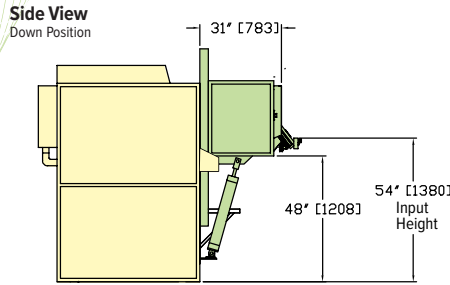
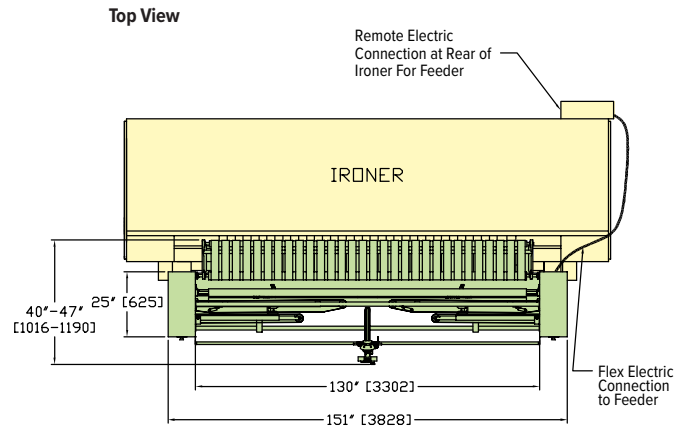
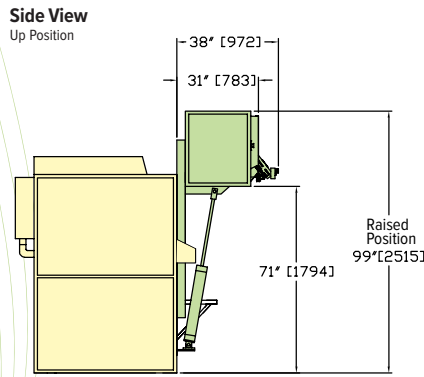

Features

- Enables one person to efficiently operate a complete finishing system – including feeding, ironing, folding and stacking sheets or large table linen
- Ideal when built into a new Chicago Tri-Star and CrosStar Ironer/Folder or Chicago Imperial Series Ironer
- Can also be loaded alternately by two people for increased production at higher speeds
- Slim design fits in almost any laundry – this built-in model adds less than 40" (1000 mm) to the front-to-rear floorspace required for an ironer or ironer/folder
- Operators have a clear view of spread items for stain/tear quality control
- CHI•Touch PC-based control for adjustments and testing.
- Processes king, queen, double or single sheets, as well as table linen larger than 54", by lifting large items above floor level for improved spreading and free suspension of linen off floor
- Above-ironer design raises out of the way pneumatically to allow small pieces to be fed directly onto the iron-er's feedboard and does not interfere with ironer's return-to-front operator function
- CHI•Touch controlled spreading by timing belt with linen laydown by air pulse
- Variable speed range up to 110 FPM
- Exclusive air foil laydown for top quality finished linen

Visit Chicago's website www.chidry.com for easy access to the latest floorplans, technical specifications, etc.

A Complete Range of Separating, Feeding, Ironing, Folding, and Sorting Options

Because Chicago specializes only in flatwork finishing equipment, it can offer the world's widest range of high production separating, feeding, ironing, folding and sorting equipment. Complete flatwork finishing systems range from automated multi-roll systems producing over 2000 pounds per hour, to compact ironers for small on-premise laundries.

Chicago's performance record is unmatched in thousands of installations in commercial, hospitality, health care, textile rental, and institutional laundries. An experienced Chicago professional will be pleased to make

an objective equipment recommendation based on your production, space, utility and budget requirements. All equipment is designed and built in Chicago for complete quality control and prompt service and parts availability, including overnight delivery if necessary.

Contact your local Chicago distributor or the factory sales assistance office for a no-obligation analysis of your needs. Visit our newly redesigned and now mobile friendly website www.chidry.com for easy access to current product brochures, detailed floor plans, and specifications, as well as videos of select Chicago products in action.

CHICAGO®



CHICAGO DRYER COMPANY
2200 North Pulaski Road
Chicago, Illinois 60639-3737 USA

Phone • 773.235.4430
Fax • 773.235.4439
Web • www.chidry.com
Email • chicago@chidry.com

Bulletin #7591