

March 2006  
Aftermarket Solutions, Ref. No. [349]

# High Resistance Grounding System

## Contents

<i>Description</i>	<i>Page</i>
<b>High Resistance Grounding System</b>	
Type C-HRG (Low Voltage) . . . . .	16-2
Product Description . . . . .	16-2
Product History . . . . .	16-2
Product History Time Line . . . . .	16-2
General Information . . . . .	16-2
Sequence of Operations . . . . .	16-3
Catalog Numbering System . . . . .	16-4
Further Information . . . . .	16-4
Type C-HRG (Medium Voltage) . . . . .	16-5
Product Description . . . . .	16-5
Product History . . . . .	16-5
Product History Time Line . . . . .	16-5
General Information . . . . .	16-5
Sequence of Operations . . . . .	16-6
Catalog Numbering System . . . . .	16-7



*Type C-HRG Products*

Type C-HRG (Low Voltage)

Type C-HRG (Low Voltage)

Originally a Westinghouse Product



Wall Mounted C-HRG  
(resistors not shown)



Free-Standing C-HRG

Product Description

Cutler-Hammer® Type C-HRG from Eaton’s electrical business is designed to improve the continuity of electrical service to critical processes. Systems designers sometimes use ungrounded distribution systems to avoid interrupting service during a ground fault. However, ungrounded systems have a significant disadvantage — the distribution system is subject to the harmful effects of ground faults, like high transient overvoltages. The Type C-HRG helps customers add the benefits of a grounded system to their ungrounded system.

Product History

High resistance grounding technology has been offered as an integral system within our low voltage switchgear and switchboard products since the early 1970s. In 1994, Eaton adopted the technology into the C-HRG, which is a stand-alone or wall-mounted product ideal for adapting to the existing electrical system.

Product History Time Line

Product	1994	2000	Present
C-HRG Low Voltage			

Figure 16-1. Product History Time Line

General Information

Overview

Where continuity of service is a high priority, high resistance grounding can add the safety of a grounded system while minimizing the risk of service interruptions due to grounds. The concept is a simple one: provide a path for ground current via a resistance that limits the current magnitude, and monitor to determine when an abnormal condition exists.

The ground current path is provided at the point where the service begins by placing resistance in the connection from system neutral-to-ground. Control equipment continuously measures ground current; a relay detects when the current exceeds a predetermined level. An alarm alerts building personnel that a ground exists. The system has built-in fault tracing means to assist in finding the source of the ground. An integral transformer provides control power from the primary source.

Minimum Criteria for Use

High resistance grounding systems can be applied to either grounded or ungrounded 3-wire distribution systems. Per NEC® 1996, 250-5(b) exception No. 5, the following criteria must be met before using the C-HRG:

- The conditions of maintenance and supervision ensure that only qualified persons will service the installation.
- Continuity of power is required.
- Ground detectors are installed on the system.
- Line-to-neutral loads are not served.

Wye or Delta System

Adding the Type C-HRG to a Wye connected system requires only that the resistors supplied be connected in series with the neutral-to-ground connection of the power source. Adding the Type C-HRG to an ungrounded Delta system requires the creation of a neutral point. Transformers are supplied for that purpose in the enclosure. The resistors supplied are then connected at that point. In both cases, the components supplied are chosen to limit the ground current to a maximum value of 5 amperes.

March 2006

Aftermarket Solutions, Ref. No. [351]

Type C-HRG (Low Voltage)

## General Information (Continued)

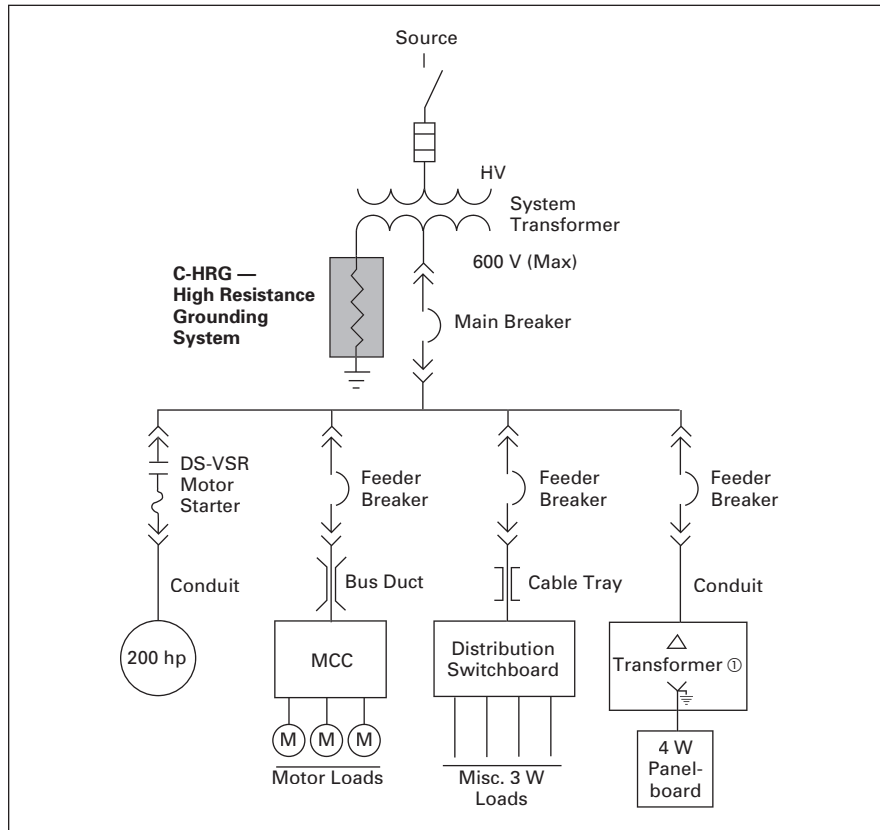

Figure 16-2. Typical C-HRG Application

① Phase-to-neutral loads cannot be fed from the same system transformer to which the C-HRG is connected. These loads must be fed from downstream, Delta-Wye transformer with a solidly grounded neutral on the secondary.

## Ground Fault Detection

When one phase of a system becomes grounded, additional current will flow. As all ground current must flow through the grounding resistor assembly, a current sensing relay is placed in this circuit allowing detection when a ground fault occurs. If chosen, a voltage sensing relay can be provided to accomplish the same function.

## Pulser Circuit

The pulser circuit offers a convenient means to locate the faulted feeder and trace the fault to its origin. The pulser is available any time a fault has been detected. The "pulse" light flashes on and off, corresponding to the ON-OFF cycles of the pulsing contactor. The pulser contactor switches a bank of resistors on and off, allowing a momentary increase in the ground current.

## Ground Fault Location

The current pulses can be noted with a clamp-on ammeter when the ammeter is placed around the cables or conduit feeding the fault. The operation tests each conduit or set of cables until the pulsing current is noted. By moving the ammeter along the conduit, the fault can be traced to its origin. The fault may be located at the point where the pulsing current drops off or stops. If little or no change in the pulsing current is noted along the entire length of a conduit, then the fault may be in the connected load.

## Sequence of Operations

## Normal

- Green "normal" light on.
- Red "ground fault" light off.
- White "pulse" light off.
- System control switch in "normal" position.
- Reset control switch in either "auto" or "manual."

## Test

- Turn and hold the system control switch in the "test" position. Phase B will be grounded via the test resistor.
- The ground current will activate the sensing circuit, causing the green "normal" light to turn off and the red "ground fault" light to turn on. The pulser will be activated as well.
- The white "pulse" light will turn on and off as the pulser contactor closes and opens.
- The ground current ammeter will display the total ground current, including the incremental pulse current.
- When ready, return the system control switch to "normal." The pulser will stop. If the reset control is in the "manual" position, turn it to "reset" to reset the fault sensing circuit.
- The red "ground fault" light will turn off, and the green "normal" light will turn on.
- Test mode is not available if the system is detecting a ground. The sensing circuit will disable the test circuit.

## Ground Fault

- When the sensing circuit detects a fault, the green "normal" light will turn off and the red "ground fault" light will turn on.
- The ground current ammeter will indicate the total ground current.
- To use the pulser, turn the system control switch to "pulse." The pulser contactor will cycle on and off as controlled by the recycle timer relay.
- Use the clamp-on ammeter to locate the faulted feeder. Open the feeder and clear the fault.
- If the reset control switch is in the "manual" position, turn it to "reset" to reset the sensing circuit.

**Note:** If reset control is in "auto," it will reset itself.

- When ready to restore service to the load, close the feeder.
- Return the system control to "normal."

## Catalog Numbering System

Table 16-1. Decoding the Catalog Numbering System

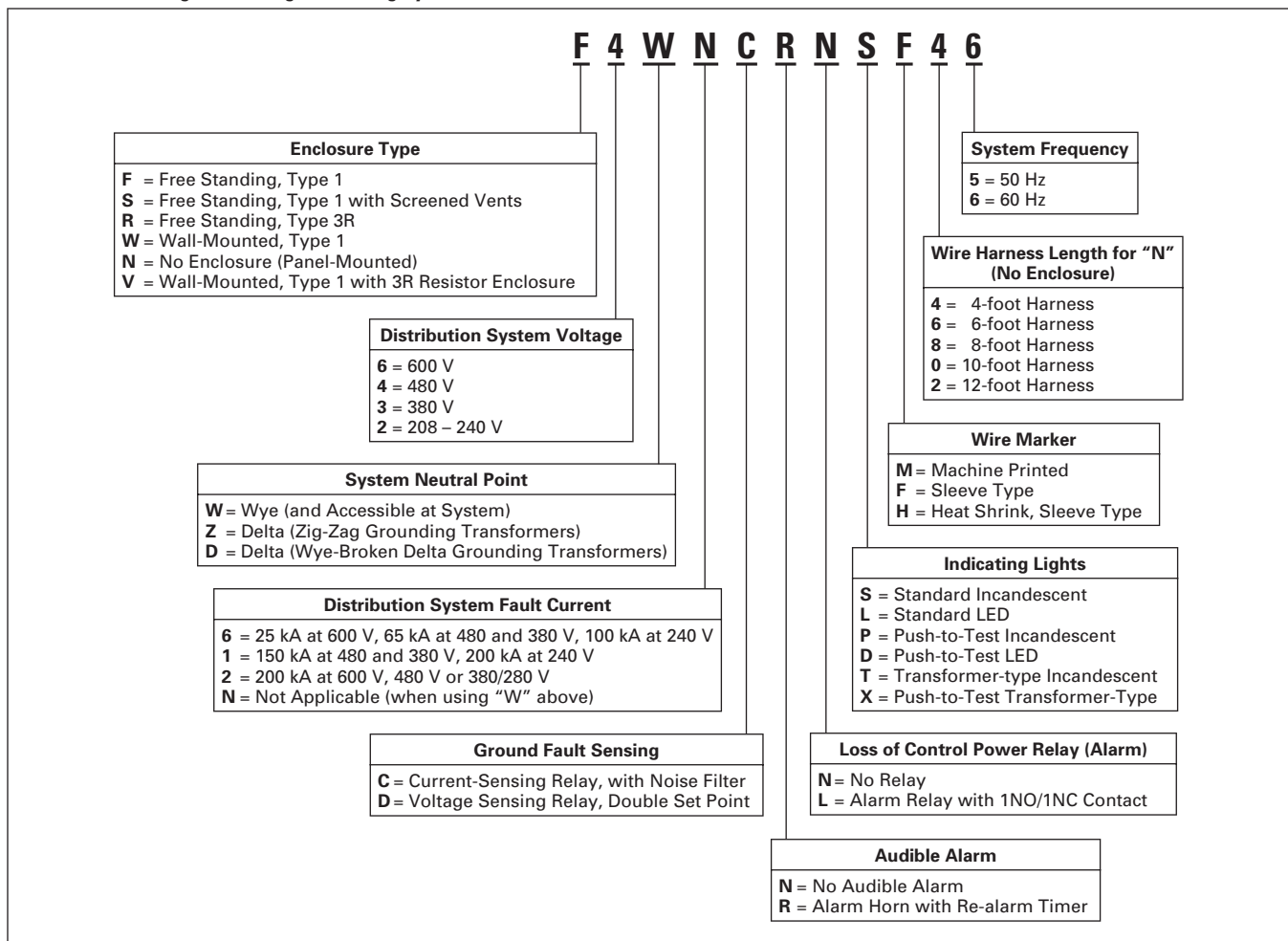

## Further Information

Publication Number	Description
SN.44C.01.S.E —	Sales Notes for C-HRG Bidman Pricing
TD.44C.01.T.E	Technical Data for C-HRG
SA-32-602B IB 32-698C CA08104001E	Sales Aid for High Resistance Grounding Systems Instruction Booklet for High Resistance Grounding System <i>Electrical Consulting Application Guide</i>

March 2006  
Aftermarket Solutions, Ref. No. [353]

Type C-HRG (Medium Voltage)

Type C-HRG (Medium Voltage)

General Information



Free-Standing C-HRG

Product Description

The Type C-HRG is designed to improve the continuity of electrical service to critical processes. Systems designers sometimes use ungrounded distribution systems to avoid interrupting service during a ground fault. However, ungrounded systems have a significant disadvantage — the distribution system is subject to the harmful effects of ground faults, like high transient overvoltages. The Type C-HRG helps customers add the benefits of a grounded system to their ungrounded system.

Product History

High resistance grounding technology has been offered as an integral system within medium voltage switchgear, for many years. In 1996, Eaton adopted the technology into the C-HRG which is a stand-alone product ideal for adapting to the existing electrical system.

Product History Time Line

Product	1995	2000	Present
C-HRG Medium Voltage			

Figure 16-3. Product History Time Line

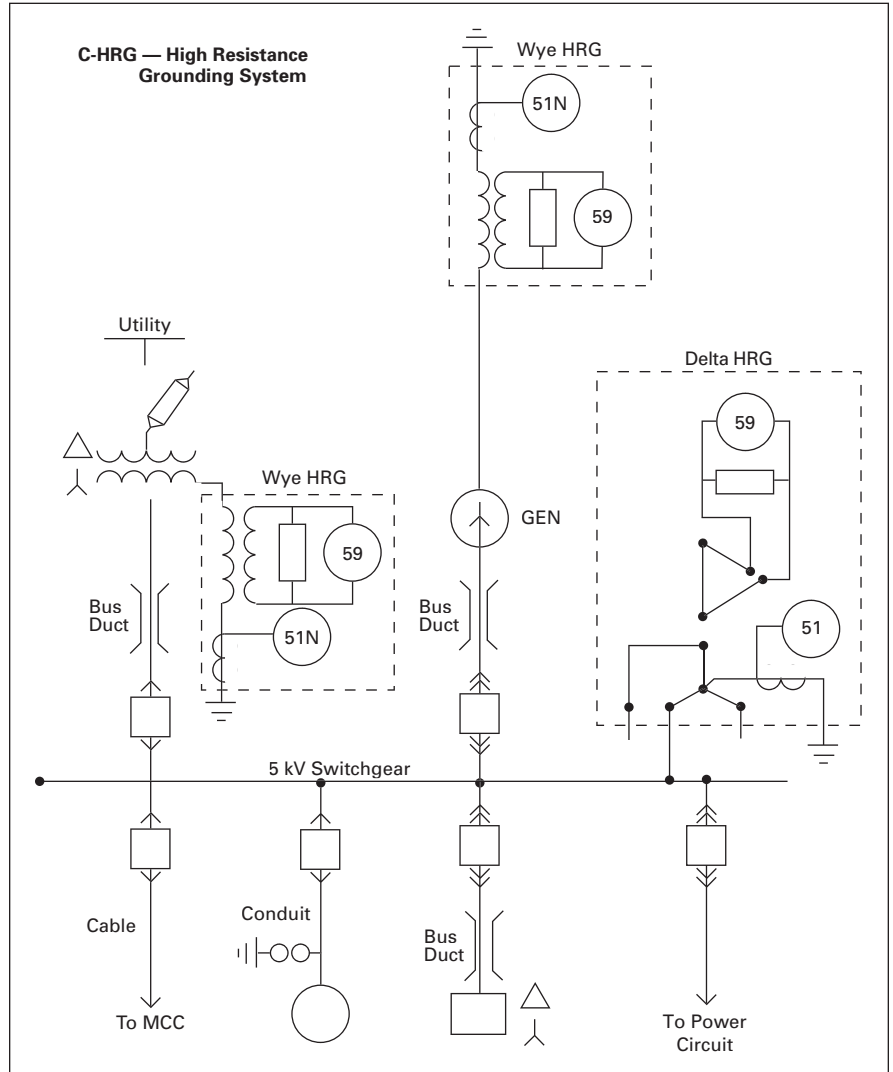

Figure 16-4. High Resistance Grounding System

Overview

Where continuity of service is a high priority, high resistance grounding can add the safety of a grounded system while minimizing the risk of service interruptions due to grounds. The concept is a simple one: provide a path for ground current via a grounding transformer (with adjustable resistance across its secondary) that limits the current magnitude and a monitor to determine when an abnormal condition exists.

The ground current path is provided at the point where the service begins, by placing a predominantly resistive impedance in the connection from system neutral to ground. Control

equipment continuously measures ground current; a relay detects when the current exceeds a predetermined level. An alarm alerts building personnel that a ground exists. The system has built-in fault tracing means to assist in finding the source of the ground. A 120 Vac supply (remote) is required for control power for the system.

Minimum Criteria for Use

The C-HRG MV is offered at the 5 kV class rating. It can be applied to delta or wye ungrounded three-wire distribution systems. Standard dimensions are 36-inch W x 40-inch D x 92-inch H.

## General Information (Continued)

### Wye or Delta System

To add high resistance grounding to a wye-connected system, resistors are placed across the secondary of a grounding transformer whose primary is placed in series with the neutral-to-ground connection of the power source. To add high resistance grounding to an ungrounded delta-connected system, a neutral point must be created. Three single-phase transformers can be interconnected in a wye-broken delta configuration to provide such a neutral point.

### Ground Fault Detection

When one phase becomes grounded, additional current above the charging level will flow. As all ground current must flow through the grounding resistor/grounding transformer assembly, an ammeter in this circuit will read the total amount of ground current. By placing a current-sensing relay in series with the ammeter, the current relay can be adjusted to pick up at a level in excess of the capacitive charging current, thus indicating the abnormal condition. Alternatively, an optional voltmeter relay can be connected across the grounding resistors, to accomplish the same function.

### Pulser Circuit

The pulser circuit offers a convenient means to locate the faulted feeder and trace the fault to its origin. The pulser is available any time a fault has been detected. The pulse intervals are controlled by an adjustable recycle timer. The "pulse" light flashes on and off, corresponding to the ON-OFF cycles of the pulser contactor. The pulser contactor switches a bank of resistors on and off, thus allowing a momentary increase in the ground current.

### Ground Fault Location

The current pulses can be noted with a clamp-on ammeter when the ammeter is placed around the cables or conduit feeding the fault. The operator tests each conduit or set of cables until the pulsing current is noted. By moving the ammeter along the conduit, or checking the conduit periodically along its length, the fault can be traced to its origin. The fault may be located at the point where the pulsing current drops off or stops. If little or no change in the pulsing current is noted along the entire length of a conduit, then the fault may be in the connected load.

### Standard Features

- Current sensing ground fault detection (2 – 10 amperes pickup/ 0.5 – 20 second delay).
- Ground current transformer (10/10 ratio).
- Control circuit pull fuseblock.
- Ground current ammeter (0 – 10 amperes, 1% accuracy).
- Indicating lights Red (ground fault) Green (normal) White (pulse).
- Adjustable pulsing timer (0 – 10 seconds).
- Tapped resistors (limits primary current to 3 – 6 amperes).
- 3-position selector switch (normal, pulse, test).
- Control switch for manual or automatic reset.
- Ground fault contacts (1NO/1NC).
- Shorting terminal block for ground current CT.
- UL® label.
- Wiremarkers.

## Sequence of Operations

### Normal

- Green "normal" light on.
- Red "ground fault" light off.
- White "pulse" light off.
- System control switch in "normal" position.
- Reset control switch in either "auto" or "manual."

### Test

- Turn and hold the system control switch in the "test" position.
- This mode will test the control circuitry only. It will bypass the sensing circuit and cause the green "normal" light to turn off and the red "ground fault" light to turn on. The pulser will be activated as well.
- The white "pulse" light will turn on and off as the pulser contactor closes and opens.
- However, the ground current ammeter will not display the total ground current, including the incremental pulse current.
- When ready, return the system control switch to "normal." The pulser will stop. If the reset control is in the "manual" position, turn it to "reset" to reset the fault sensing circuit.
- The red "ground fault" light will turn off, and the green "normal" light will turn on.
- Test mode is not available if the system is detecting a ground. The sensing circuit will disable the test circuit.

### Ground Fault

- When the sensing circuit detects a fault, the green "normal" light will turn off and the red "ground fault" light will turn on.
- The ground current ammeter will indicate the total ground current.
- To use the pulser, turn the system control switch to "pulse." The pulser contactor will cycle on and off as controlled by the recycle timer relay.
- Use the clamp-on ammeter to locate the faulted feeder. Open the feeder and clear the fault.
- If the reset control switch is in the "manual" position, turn it to "reset" to reset the sensing circuit.

**Note:** If reset control is in "auto," it will reset itself.

- When ready to restore service to the load, close the feeder.
- Return the system control to "normal."

March 2006  
Aftermarket Solutions, Ref. No. [355]

**Type C-HRG (Medium Voltage) — Catalog Numbering System**

**Catalog Numbering System**

**Customer Required Information**

A C-HRG High Resistance Grounding Assembly can be completely described by an 8-digit catalog number: MVRG-\_\_\_\_\_

**Table 16-2. Catalog Numbering System**

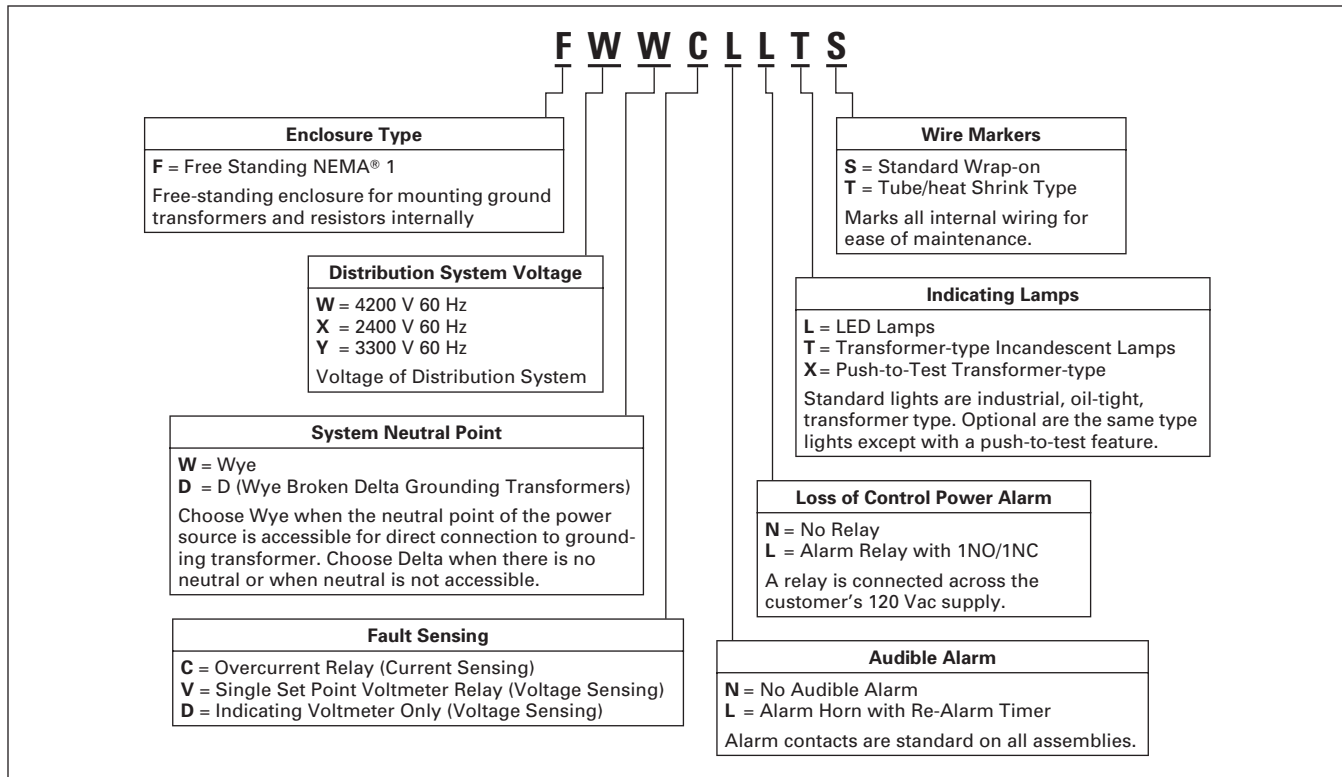

Example: MVRG-FWWCLLTS defines a free-standing Type 1 enclosure, 4200 V/60 Hz, Wye-connected system, current-sensing control scheme, alarm horn with re-alarm timer, alarm relay with 1NO and 1NC, transformer type incandescent lights, wrap-on wiremarkers.

Cutler-Hammer is a federally registered trademark of Eaton Corporation. NEMA is a registered trademark and service mark of the National Electrical Manufacturers Association. The National Electrical Code and NEC are registered trademarks of the Fire Protection Association, Quincy, Mass. UL is a registered trademark of the Underwriters Laboratories Inc.

*This page intentionally left blank.*