

## Electronic Temperature Control Pilots

### Series GT610-IP Electro-Pneumatic Transducer

The Series GT610-IP Electro-Pneumatic transducer is designed for temperature control applications with a 35 psig (2.4 bar) clean filtered air supply and where a 4 to 20 mA DC or 0 to 10 VDC signal is provided by an electronic sensor. **An Air Pressure Pilot, an Air PRV Regulator and a Series 2000 Main Valve Steam Regulator *must* be used with the Series GT610-IP Relay.**

- 6-30 psig (.42 - 2.1 bar) modulated air output
- Optional gauge ports available to monitor output signal
- Supply pressure:
  - Minimum 15 psig (1.0 bar)
  - Maximum 36 psig (2.5 bar)
- Maximum steam output pressure from main valve:
  - 21 psig (1.5 bar) model AP-1 air pressure pilot
  - 84 psig (5.8 bar) model AP-4 air pressure pilot

#### Ordering Information

Model Number	Part Number	Input Signal	Maximum Air Pressure psig (bar)	Weight lbs. (kg)
GT6108	401252	4 - 20 mA	36 (2.5)	2.5 (1.2)
GT6102	401253	0 - 10 VDC	36 (2.5)	2.5 (1.2)

Refer to Ordering Information on:

- Air Pressure Control Pilots
- Air PRV Regulators

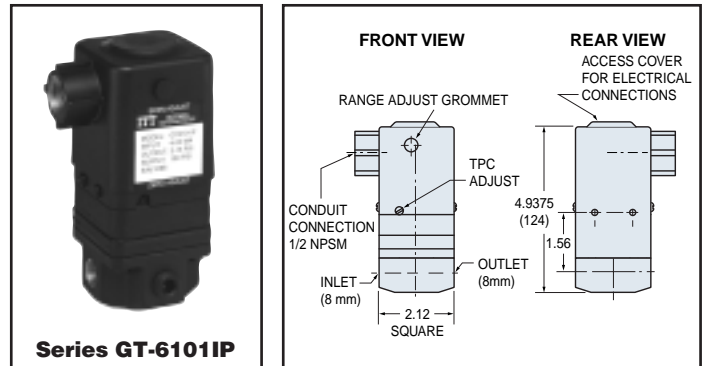

#### Typical Installation

