



Product Data Submittal

Fulton RB Horizontal Firetube Boilers

Fulton Models: RB-60, RB-75, RB-100, RB-125, RB-150, RB-185, RB-210, RB-250, RB-300

Dimensions

Models	RB	60	75	100	125	150	185	210	250	300
A. Shell Length	IN	92.25	100.25	120.00	135.25	135.25	147.50	147.50	151.75	153.75
	MM	2,343	2,546	3,048	3,435	3,435	3,746	3,746	3,854	3,905
B. Furnace Length	IN	78.75	84.75	102.25	115.75	115.75	126.00	126.00	130.25	130.25
	MM	2,000	2,152	2,597	2,940	2,940	3,200	3,200	3,308	3,308
C. Tube Removal	IN	76.75	78.75	104.25	116.25	116.25	124.00	124.00	128.25	128.25
	MM	1,949	2,000	2,648	2,953	2,953	3,150	3,150	3,258	3,258
D. Door Opening	IN	59.00	59.00	67.00	69.00	69.00	75.00	75.00	82.50	86.50
	MM	1,499	1,499	1,702	1,753	1,753	1,905	1,905	2,096	2,197
E1. Oil Burner	IN	27.00	27.00	27.00	29.00	29.00	29.00	29.00	36.00	36.00
	MM	686	686	686	737	737	737	737	914	914
E2. Gas Burner	IN	46.50	46.50	46.50	46.50	46.50	43.00	43.00	35.75	35.75
	MM	1,181	1,181	1,181	1,181	1,181	1,092	1,092	908	908
F. Overall Width	IN	74.00	77.00	77.00	84.75	84.75	89.75	89.75	97.75	101.50
	MM	1,880	1,956	1,956	2,153	2,153	2,280	2,280	2,483	2,578
G. Shell Diameter	IN	55.00	59.00	59.00	65.00	65.00	71.00	71.00	78.75	82.75
	MM	1,397	1,499	1,499	1,651	1,651	1,803	1,803	2,000	2,000
H. Steam Outlet to Floor	IN	82.50	82.50	82.50	88.50	88.50	94.50	94.50	102.75	114.25
	MM	2,096	2,096	2,096	2,248	2,248	2,400	2,400	2,610	2,902
I. Flue Outlet to Floor*	IN	65.00	67.00	67.00	72.75	72.75	77.75	77.75	84.75	87.50
	MM	1,651	1,702	1,702	1,848	1,848	1,975	1,975	2,153	2,223
J. Flue Diameter*	IN	14.00	14.00	14.00	16.00	16.00	18.00	18.00	20.00	20.00
	MM	356	356	356	406	406	457	457	508	508

Approximate Weights

Water Content	GAL	557	557	660	983	983	1,389	1,389	1,606	1,664
	LITERS	2,108	2,108	2,498	3,721	3,721	5,258	5,258	6,079	6,299
Dry Weight	LB	10,304	10,528	12,992	16,800	17,472	19,040	20,160	23,296	26,880
	KG	4,674	4,775	5,893	7,620	7,925	8,636	9,144	10,577	12,193

Specifications and Dimensions are approximate. We reserve the right to change specifications and/or dimensions.

* For reference only - Consult factory for options.

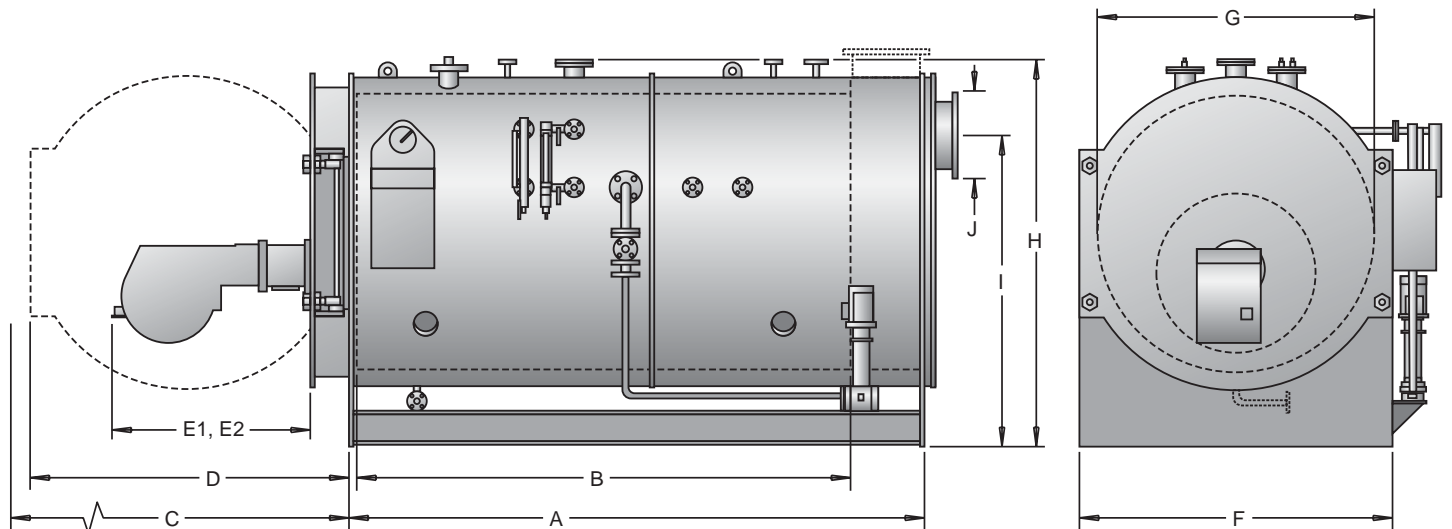

Specifications

Models	RB	60	75	100	125	150	185	210	250	300
Heat Output	MBH	2,009	2,510	3,347	4,184	5,021	6,192	7,029	8,368	10,042
Max Operating Pressure	PSI	150	150	150	150	150	150	150	150	150
	BAR	10.34	10.34	10.34	10.34	10.34	10.34	10.34	10.34	10.34
Steam Output	LBS/HR	2,070	2,588	3,450	4,313	5,175	6,383	7,245	8,625	10,350
	KG/HR	939	1,174	1,565	1,956	2,347	2,895	3,286	3,912	4,695
Heat Transfer Area	FT. ²	213	260	307	398	435	518	546	735	827
	M ²	20	24	29	37	41	48	51	68	77

Approximate Fuel Usage

Light Diesel Oil	GPH	17.0	21.5	28.5	35.5	42.5	52.5	59.5	71.0	85.0
	LPH	64	81	108	134	161	199	225	269	322
Natural Gas	FT ³ /HR	2,363	2,956	3,964	4,923	5,908	7,409	8,274	9,849	11,820
	M ³ /HR	720	901	1,126	1,501	1,801	2,258	2,522	3,002	3,603
Gas Pressure	Min. W.C.	6.5	7.3	10.3	12.3	11.7	15.9	14.9	17.3	27.2
	Max. W.C.	27.7	27.7	27.7	27.7	27.7	27.7	27.7	27.7	10 PSI

Connections

Steam Outlet	IN	2.5	2.5	2.5	4.0	4.0	4.0	4.0	6.0	6.0
	MM	64	64	64	102	102	102	102	152	152
Safety Valve Outlet	IN	1.25	1.25	1.50	2x1.25	2x1.25	2x1.50	2x1.50	2x1.50	2x1.50
	MM	32	32	38	2x32	2x32	2x38	2x38	2x38	2x38
Drain Outlet	IN	1.5	1.5	1.5	1.5	1.5	1.5	1.5	1.5	1.5
	MM	38	38	38	38	38	38	38	38	38
Feed Water Pump Inlet	IN	1.25	1.25	1.25	1.25	1.25	1.25	1.25	1.25	1.25
	MM	32	32	32	32	32	32	32	32	32
Gas Inlet - Natural Gas	IN	2.0	2.0	2.5	3.0	3.0	3.0	3.0	3.0	3.0
	MM	51	51	64	76	76	76	76	76	76

Power

Burner Fan - Gas	BHP	1.0	1.5	3.0	5.0	7.5	7.5	15.0	10.0	15.0
	KW	.75	1.1	2.2	3.7	5.6	5.6	11.2	7.5	11.2
Burner Fan - Oil	BHP	1.5	2.0	5.0	5.0	7.5	7.5	15.0	10.0	15.0
	KW	1.1	1.5	3.7	3.7	5.6	5.6	11.2	7.5	11.2
Burner Fan - Gas/Oil	BHP	1.5	2.0	5.0	5.0	7.5	7.5	15.0	10.0	15.0
	KW	1.1	1.5	3.7	3.7	5.6	5.6	11.2	7.5	11.2

Electrical Requirements/Amps for Burner Motors

Gas										
208V, 60 CY, 3 Phase		2.1	3.1	6.1	10.3	15.6	15.6	31.1	20.8	31.1
230V, 60 CY, 3 Phase		1.9	2.8	5.5	9.3	14.1	14.1	28.1	18.8	28.1
460V, 60 CY, 3 Phase		1.0	1.4	2.8	4.6	7.0	7.0	14.1	9.4	14.1

Oil & Gas/Oil Combo

208V, 60 CY, 3 Phase		3.1	4.2	10.3	10.3	15.6	15.6	31.1	20.8	31.1
230V, 60 CY, 3 Phase		2.8	3.8	9.3	9.3	14.1	14.1	28.1	18.8	28.1
460V, 60 CY, 3 Phase		1.4	1.9	4.6	4.6	7.0	7.0	14.1	9.4	14.1

Specifications and Dimensions are approximate. We reserve the right to change specifications and/or dimensions.



Fulton Boiler Works, Inc.
 3981 Port Street, Box 257
 Pulaski, New York USA 13142
 Call: 315-298-5121
 Fax: 315-298-6390
 www.fulton.com

RB PDS
 Rev. 01/07
 Printed in USA