

D51 • D61 • D71 • D91 Series Centrifugal Pumps



- Capacities to 240 GPM
- Heads to 360 Feet

MTH PUMPS

D51 • D61 • D71 • D91 Series Centrifugal Pumps

Casing

Standard casing construction of all units is ASTM A48 Class 30 cast iron. All bronze casings are currently available in the D71 and D91 Series only. In all models, the discharge can be rotated to any 90° position and NPT suction and discharge ports are standard. Back pull out design allows the pump to be serviced without disturbing the piping. The volute was designed to maximize hydraulic efficiency.

Mechanical Seal

All D51 • D61 Series pumps with 56J frame motors use a 5/8" Type 21 Buna-N seal which is rated to 225°F and pressures to 175PSI. The D71 • D91 Series pumps on 143JM through 215JM frames use a 1 1/4" Type 21 seal while 254JM through 326JM frames use a 1 5/8" Type 21 Buna-N seal which is rated to 225°F and pressures to 250PSI. The carbon seal face mates with a ceramic seat providing years of trouble-free service. The seal cooling jacket high temperature version of the D51 unit uses a Type 21 Viton seal that is rated to 400°F with pressures to 175PSI. Alternate seals are available upon request.

Impeller

The hydraulic design of the enclosed impellers maximizes pressure and capacity while minimizing horsepower. All standard D Series models feature a cast impeller made of CDA87500 silicon bronze for high temperature resistance. The high temp version of the D51 also features

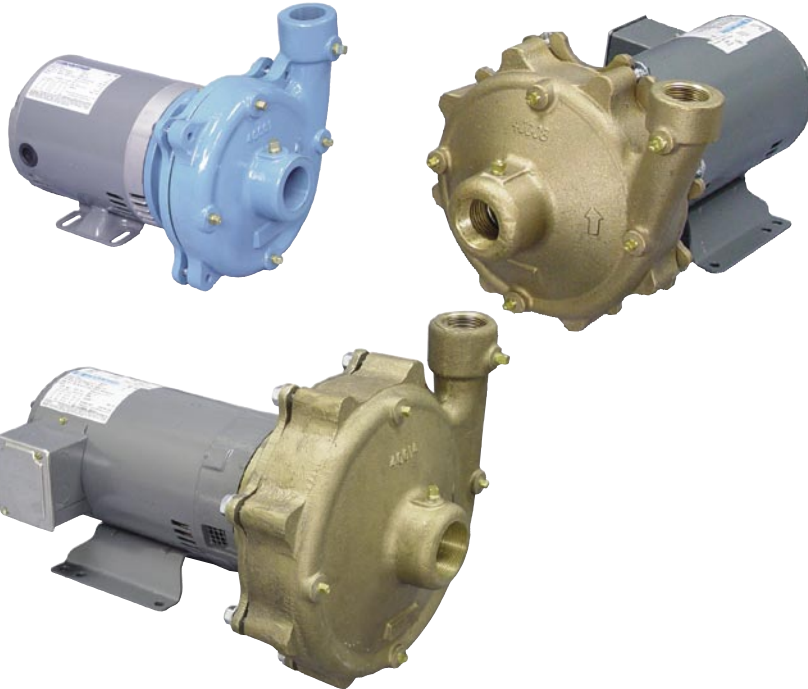

a pressed-on throttle bushing which fits snugly into the motor bracket to restrict hot fluid circulation into the cooled seal cavity.

Motor Bracket

Standard construction for motor brackets is ASTM A48 Class 30 cast iron, while the D71 and D91 Series are also available in bronze. Precise machining of the D Series motor brackets allows easy assembly of the pumps. A 1/8" NPT hole is provided in the motor bracket for a seal flush line if desired. The D51 also comes in a high temp version that has a motor bracket with a cast-in seal cooling jacket which allows fluids up to 500°F to be pumped without damage to the

mechanical seal or the motor. The seal chamber is specially machined to allow minimal hot liquid circulation, which keeps the area cool. The water jacket has 1/2" NPT ports every 90° for easy water line connections.

Motor

The NEMA JM frame motor found on the D71 and D91 Series utilizes a high carbon steel shaft. The NEMA 56J frame motors used on the D51 and D61 Series utilize a 416 stainless steel shaft. The motor's heavy duty ball bearings withstand heavy axial and radial thrust loads. Standard enclosure type is open drip-proof with alternatives available on request.

STANDARD MATERIALS

PART	BRONZE FITTED	ALL BRONZE
Motor Bracket	Cast Iron ASTM A48	Bronze ASTM B62
Casing	Cast Iron ASTM A48	Bronze ASTM B62
Impeller	Bronze CDA 87500	Bronze CDA 87500
56J Motor Shaft	Stainless Steel AISI 416	Stainless Steel AISI 416
JM Motor Shaft	High Carbon Steel	High Carbon Steel
"O" Rings	Buna N	Buna N
Seals	Carbon/Buna	Carbon/Buna
Seats	Ceramic/Buna	Ceramic/Buna

LIMITATIONS

Discharge Pressure	250 PSI
Suction Pressure (Max)	250 PSI
Suction Pressure (Min)	26" Hg Vac.
Speed (Max.)	3600 RPM
Temperature	
Standard Construction	-20° F
Ceramic Seal Seat - Water Graph. Imp. Silicon Carbide	+225° F
Seal Seat & Seal Flush	+250° F
Cooling Jacketed	500° F
Horsepower	
56J Frame	3 HP
JM Frame	100 HP

D51 SERIES

Horizontal Close Coupled

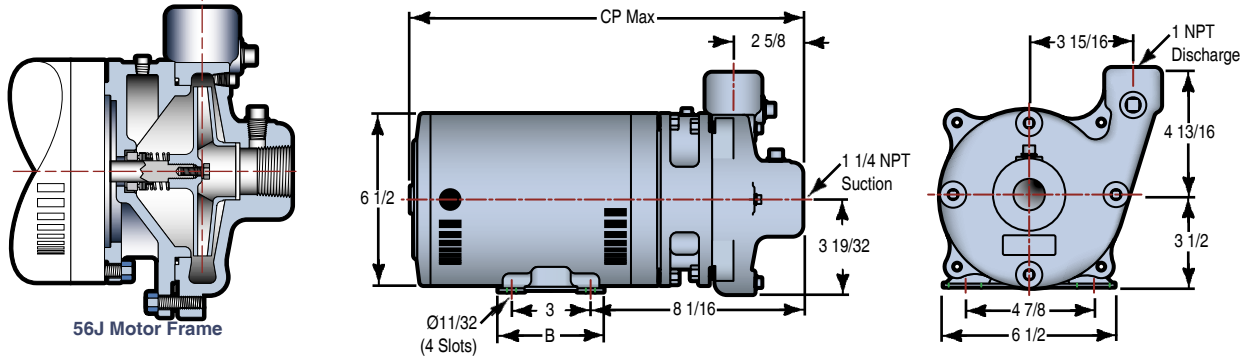

D51CD (1 X 1 1/4 X 5)

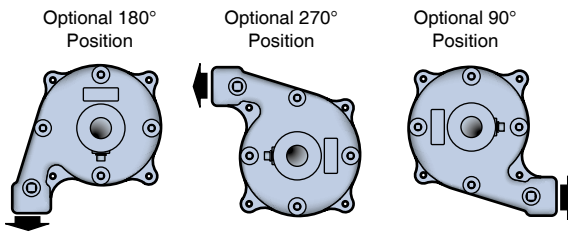

HP	FRAME	B	CP MAX	
			3Ø 208-230/460V	1Ø 115/230V
1/3	56J	3 3/4	14	13 7/8
1/2	56J	3 3/4	14 1/8	14 3/8
3/4	56J	4	14 3/4	15
1	56J	4	15 3/16	15 1/2
1 1/2	56J	4	16 3/4	16 3/4
2	56J	6 1/2	16 3/4	17 1/2
3	56J	6 1/2	16 3/4	18 1/4

NOTE: All Dimensions in inches

D61 SERIES

Horizontal Close Coupled

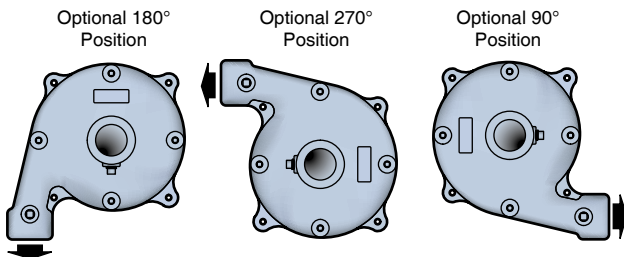
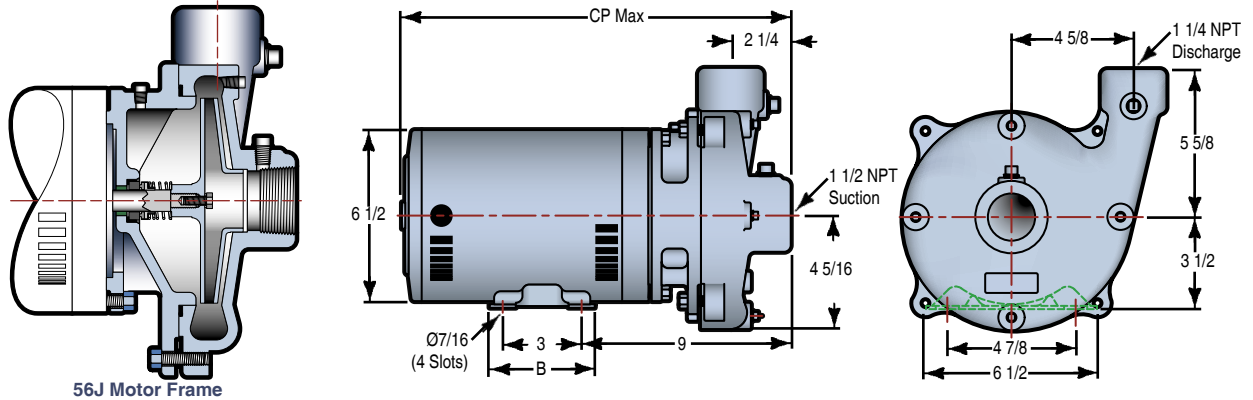

D61DE (1 1/4 X 1 1/2 X 6)

HP	FRAME	B	CP MAX	
			3Ø 208-230/460V	1Ø 115/230V
1/3	56J	3 3/4	14 1/8	14 5/8
1/2	56J	3 3/4	14 7/8	15 1/8
3/4	56J	4	15 3/8	15 3/4
1	56J	4	15 7/8	16 1/4
1 1/2	56J	4	17 9/16	17 5/8
2	56J	6 1/2	17 9/16	18 1/4
3	56J	6 1/2	17 9/16	19

NOTE: All Dimensions in inches

D71 SERIES

Horizontal Close Coupled

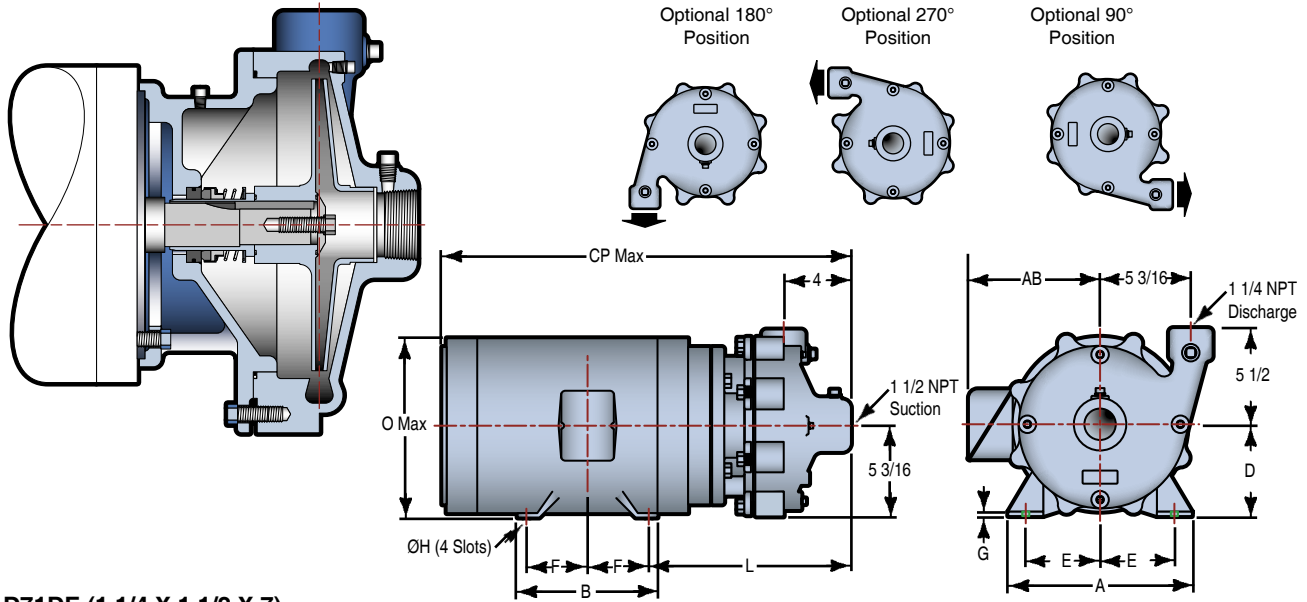

D71DE (1 1/4 X 1 1/2 X 7)

HP	FRAME SIZE	A	AB	B	CP MAX	D	E	F	G	H	L	O
1, 1 1/2	143JM	7	5 1/4	5 7/8	22 3/4	3 1/2	2 3/4	2	1/8	11/32	10 5/16	6 7/8
2, 3	145JM	7	5 1/4	5 7/8	22 1/4	3 1/2	2 3/4	2 1/2	1/8	11/32	10 5/16	6 7/8
5	182JM	9	5 7/8	6 1/2	25 3/32	4 1/2	3 3/4	2 1/4	3/16	13/32	10 13/32	8 7/16
7 1/2	184JM	9	5 7/8	6 1/2	25 15/16	4 1/2	3 3/4	2 3/4	3/16	13/32	10 13/32	8 7/16
10	213JM	10 1/2	7 3/8	8	27 5/8	5 1/4	4 1/4	2 3/4	1/4	13/32	11 9/16	10 1/16
15	215JM	10 1/2	7 3/8	8	29 1/8	5 1/4	4 1/4	3 1/2	1/4	13/32	11 9/16	10 1/16

D91 SERIES

Horizontal Close Coupled

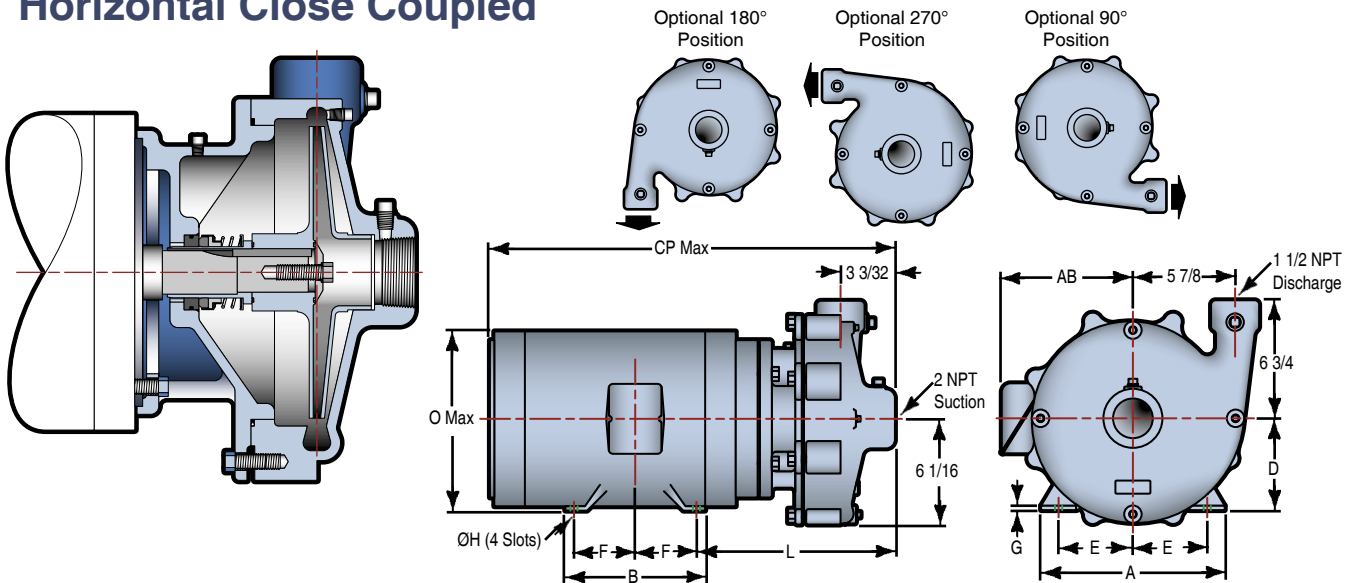

D91EF (1 1/2 X 2 X 9)

HP	FRAME SIZE	A	AB	B	CP MAX	D	E	F	G	H	L	O
1, 1 1/2	143JM	7	7 1/16	5 7/8	22 19/32	3 1/2	2 3/4	2	1/8	11/32	10 5/32	7 1/2
2, 3	145JM	7	7 1/16	5 7/8	24 3/32	3 1/2	2 3/4	2 1/2	1/8	11/32	10 5/32	7 1/2
5	182JM	9	8 1/8	6 1/2	24 15/16	4 1/2	3 3/4	2 1/4	3/16	13/32	10 21/32	9 3/8
7 1/2	184JM	9	8 1/8	6 1/2	25 15/16	4 1/2	3 3/4	2 3/4	3/16	13/32	10 21/32	9 3/8
10	213JM	10 1/2	9 5/8	8	27 15/32	5 1/4	4 1/4	2 3/4	1/4	13/32	11 13/32	11
15	215JM	10 1/2	9 5/8	8	28 31/32	5 1/4	4 1/4	3 1/2	1/4	13/32	11 13/32	11
20	254JM	12	11	11	25 13/16	6 1/4	5	4 1/8	1/4	17/32	13 21/32	14 1/8
25	256JM	12	11	11	27 9/16	6 1/4	5	5	1/4	17/32	13 21/32	14 1/8

NOTE: All Dimensions in inches

Optional Features

500°F Seal Cooling Jacket

Extends maximum working temperature of the D51 up to 500°F with an appropriate customer provided external cooling fluid source connected to the cooling jacket ports.

Self-Priming Option

The cover casing of the D51 and D61 can be replaced with a self-priming chamber to aid pump priming where lifting fluids from a sump or lower elevation is necessary. In these applications, the self-priming version lowers maintenance by helping to prevent the pump from running dry and extending the life of the pump seals.

Vertical Configuration

The D51 pumps are also available in a vertical flange mount configuration for tank mounted designs and special applications. The standard flange is compatible with a Shipco/Dunham-Bush/MEPCO. Flange adapter plates are available to fit other applications.

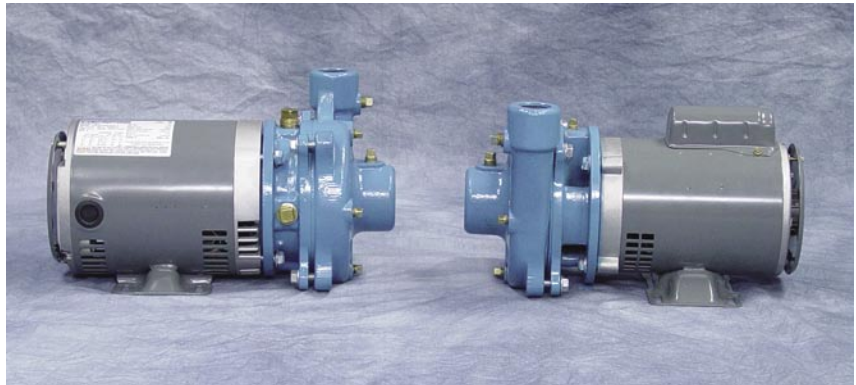

Cooling Jacketed D51CD Series vs. Standard D51CD



Self Priming D51 • D61 Series



Vertical Flange Mount D51 Series

D51 • D61 SERIES Self-Priming

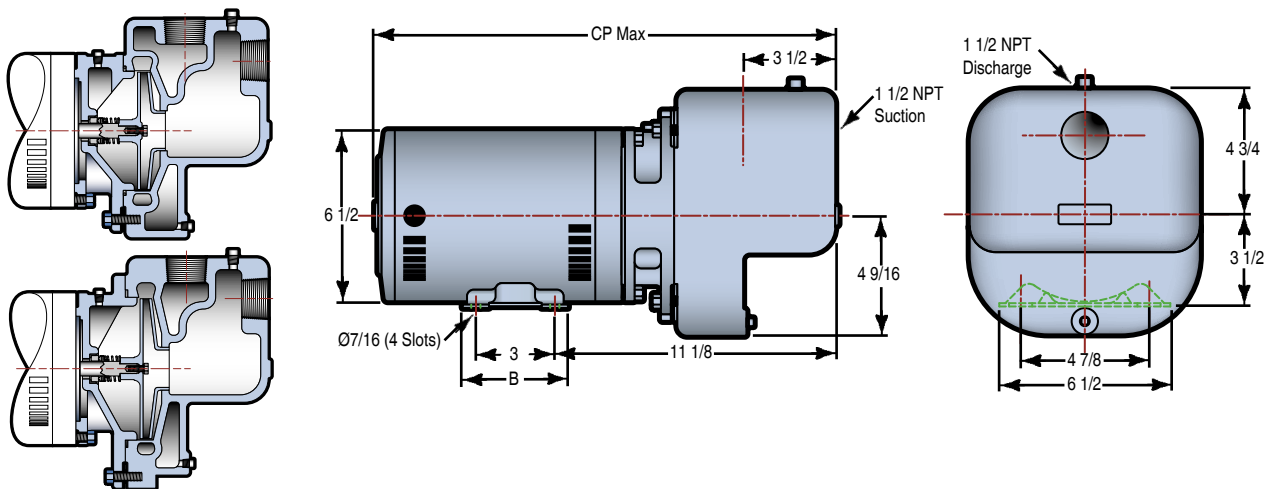

D51EE (1 1/2 X 1 1/2 X 5) Self-Priming

HP	FRAME	B	CP MAX	
			3Ø 208-230/460V	1Ø 115/230V
1/3	56J	3 3/4	14	13 7/8
1/2	56J	3 3/4	14 1/8	14 3/8
3/4	56J	4	14 3/4	15
1	56J	4	15 3/16	15 1/2
1 1/2	56J	4	16 3/4	16 3/4
2	56J	6 1/2	16 3/4	17 1/2
3	56J	6 1/2	16 3/4	18 1/4

D61EE (1 1/2 X 1 1/2 X 6) Self-Priming

HP	FRAME	B	CP MAX	
			3Ø 208-230/460V	1Ø 115/230V
1/3	56J	3 3/4	14 1/8	14 5/8
1/2	56J	3 3/4	14 7/8	15 1/8
3/4	56J	4	15 3/8	15 3/4
1	56J	4	15 7/8	16 1/4
1 1/2	56J	4	17 9/16	17 5/8
2	56J	6 1/2	17 9/16	18 1/4
3	56J	6 1/2	17 9/16	19

NOTE: All Dimensions in inches

D51 SERIES Cooling Jacketed

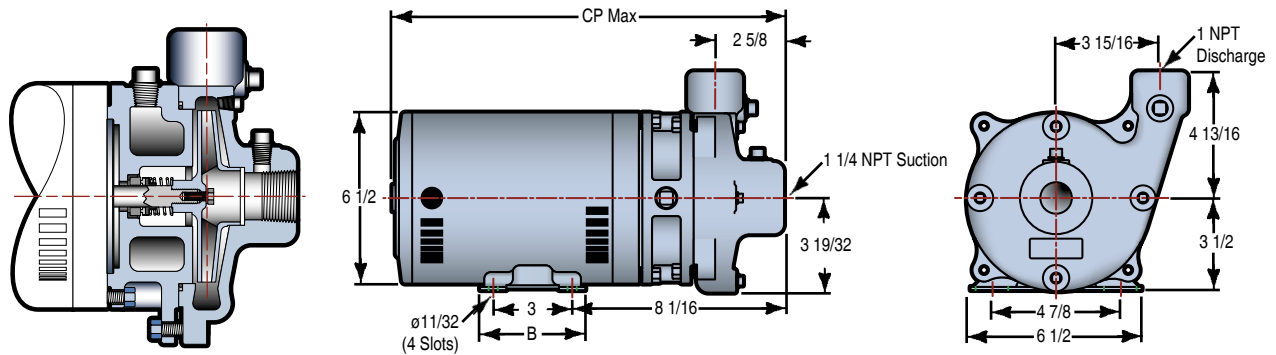

D51CD (1 X 1 1/4 X 5) Cooling Jacketed

HP	FRAME	B	CP MAX	
			3Ø 208-230/460V	1Ø 115/230V
1/3	56J	3 3/4	14	13 7/8
1/2	56J	3 3/4	14 1/8	14 3/8
3/4	56J	4	14 3/4	15
1	56J	4	15 3/16	15 1/2
1 1/2	56J	4	16 3/4	16 3/4
2	56J	6 1/2	16 3/4	17 1/2
3	56J	6 1/2	16 3/4	18 1/4

NOTE: All Dimensions in inches

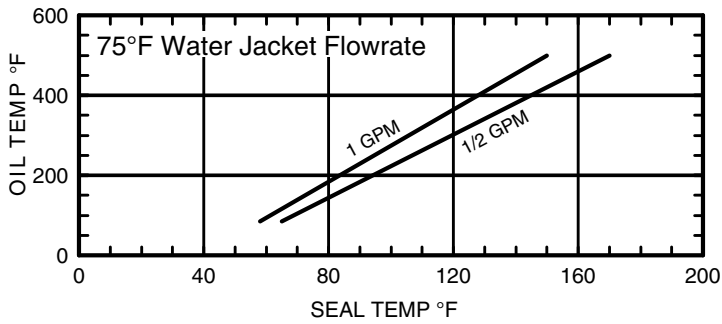

D51 SERIES Vertical Flange Mounted

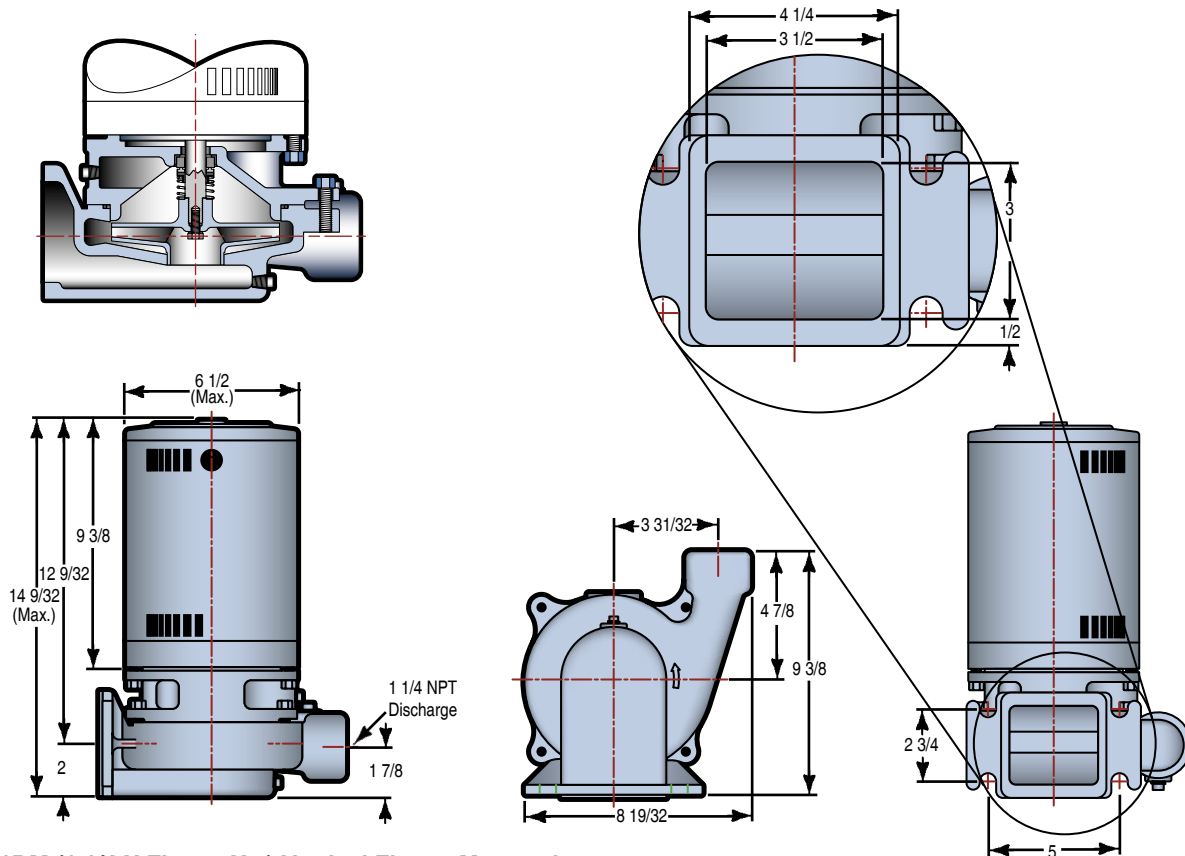

D51DM (1 1/4 X Flange X 5) Vertical Flange Mounted
See Diagram for Dimensions in Inches

Engineering Specification

Horizontal Close-Coupled

The contractor shall furnish (and install as shown on the plans) a close coupled, centrifugal, (bronze fitted) (all bronze) pump model _____. Pump shall have a standard NPT discharge size of ____" and a suction size of ____" and shall have a capacity of ____GPM when operated at a total head of ____feet.

The pump casing shall be a radially split, horizontal close-coupled end suction style. The casing shall be rotated to a (0° or 12 o'clock) (90°) (180°) (270°) mounting position. There shall be four drain/air ports drilled and tapped 90° apart. The casing should feature a back pull out design.

The pump is to be furnished with a mechanical seal which incorporates stainless steel parts, (Buna-N) (EPR) (Viton) elastomers, and a (Carbon/Ceramic) (Silicon Carbide) seal/seat.

The motor bracket shall be drilled and tapped to allow for the possible addition of a seal flush line.

The pump shall be close-coupled to a NEMA (56J) (____JM) C face ____HP ____Phase ____Hertz ____Volt ____RPM (Open Drip-Proof) (TEFC) (EXP) motor. The motor shall be sized to prevent overloading at the duty point. The motor shall have a stainless steel shaft for 56J motors and high carbon steel for JM motors. All motors will have sealed bearings.

All external cast iron parts shall have at least one coat of a high grade baked on powder coat paint to retard corrosion. Each unit shall be checked by the contractor to regulate the correct pressure, voltage, and amp draw.

Vertical Flange Mount

The contractor shall furnish (and install as shown on the plans) a close coupled vertical flange mount, centrifugal, (bronze fitted) (all bronze) pump model _____. Pump shall have a standard NPT discharge size of ____" and a Shipco/Dunham Bush style flange suction and shall have a capacity of ____GPM when operated at a total head of ____feet.

The pump casing shall be a radially split, vertical flange mount style. There shall be four drain/air ports drilled and tapped 90° apart. The casing should feature a back pull out design.

The pump is to be furnished with a mechanical seal which incorporates stainless steel parts, (Buna-N) (EPR) (Viton) elastomers, and a (Carbon/Ceramic) (Silicon Carbide) seal/seat.

The motor bracket shall be drilled and tapped to allow for the possible addition of a seal flush line.

The pump shall be close-coupled to a NEMA (56J) (____JM) C face ____HP ____Phase ____Hertz ____Volt ____RPM (Open Drip-Proof) (TEFC) motor. The motor shall be sized to prevent overloading at the duty point. The motor shall have a stainless steel shaft for 56J motors and high carbon steel for JM motors. All motors will have sealed bearings.

All external cast iron parts shall have at least one coat of a high grade baked on powder coat paint to retard corrosion. Each unit shall be checked by the contractor to regulate the correct pressure, voltage, and amp draw.

Jacketed Horizontal Close-Coupled

The contractor shall furnish (and install as shown on the plans) a close coupled, centrifugal, (bronze fitted) (all bronze) pump model _____. Pump shall have a standard NPT discharge size of ____" and a suction size of ____" and shall have a capacity of ____GPM when operated at a total head of ____feet.

The pump casing shall be a radially split, horizontal end suction style. The casing shall be rotated to a (0° or 12 o'clock) (90°) (180°) (270°) mounting position. There shall be four drain/air ports drilled and tapped 90° apart. The casing should feature a back pull out design.

The pump is to be furnished with a mechanical seal which incorporates stainless steel parts, Viton elastomers, and a (Carbon/Ceramic) (Silicon Carbide) seal/seat.

The motor bracket shall be drilled and tapped to allow for a seal cooling

chilled water flow. The motor bracket shall also include a thermal isolation bushing.

The pump shall be close-coupled to a NEMA 56J C face ____HP ____Phase ____Hertz ____Volt ____RPM (Open Drip-Proof) (TEFC) motor. The motor shall be sized to prevent overloading at the duty point. The motor shall have a stainless steel shaft and sealed ball bearings.

All external cast iron parts shall have at least one coat of a high grade baked on powder coat paint to retard corrosion. Each unit shall be checked by the contractor to regulate the correct pressure, voltage, and amp draw.

Self-Priming Horizontal Close-Coupled

The contractor shall furnish (and install as shown on the plans) a close coupled self-priming, centrifugal, (bronze fitted) (all bronze) pump model _____. Pump shall have a standard NPT discharge size of ____" and a suction size of ____" and shall have a capacity of ____GPM when operated at a total head of ____feet.

The pump casing shall be a radially split, horizontal end suction self-priming style. There shall be two drain/air ports drilled and tapped. The casing should feature a back pull out design.

The pump is to be furnished with a mechanical seal which incorporates stainless steel parts, (Buna-N) (EPR) (Viton) elastomers, and a (Carbon/Ceramic) (Silicon Carbide) seal/seat.

The motor bracket shall be drilled and tapped to allow for the possible addition of a seal flush line.

The pump shall be close-coupled to a NEMA 56J C face ____HP ____Phase ____Hertz ____Volt ____RPM (Open Drip-Proof) (TEFC) motor. The motor shall be sized to prevent overloading at the duty point. The motor shall have a stainless steel shaft and sealed ball bearings.

All external cast iron parts shall have at least one coat of a high grade baked on powder coat paint to retard corrosion. Each unit shall be checked by the contractor to regulate the correct pressure, voltage, and amp draw.

D51 • D61 • D71 • D91 SERIES

Performance Curves

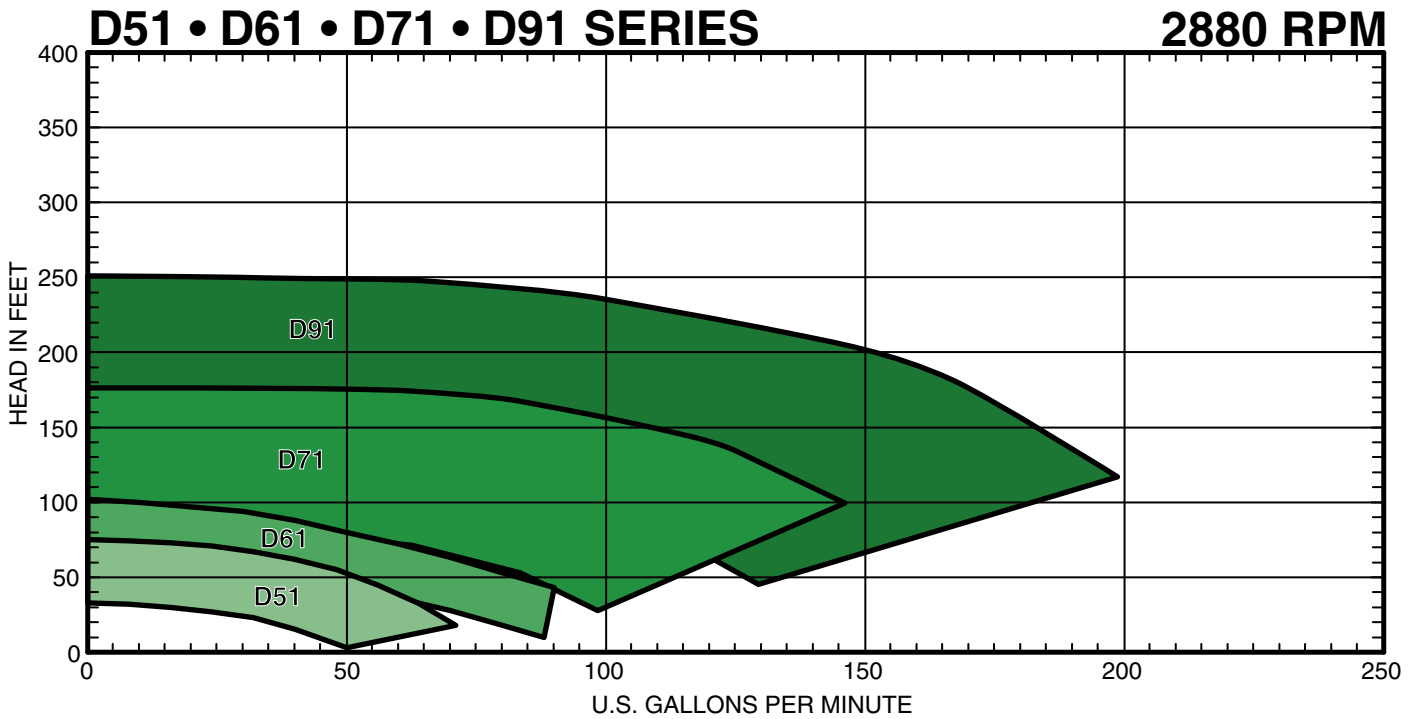
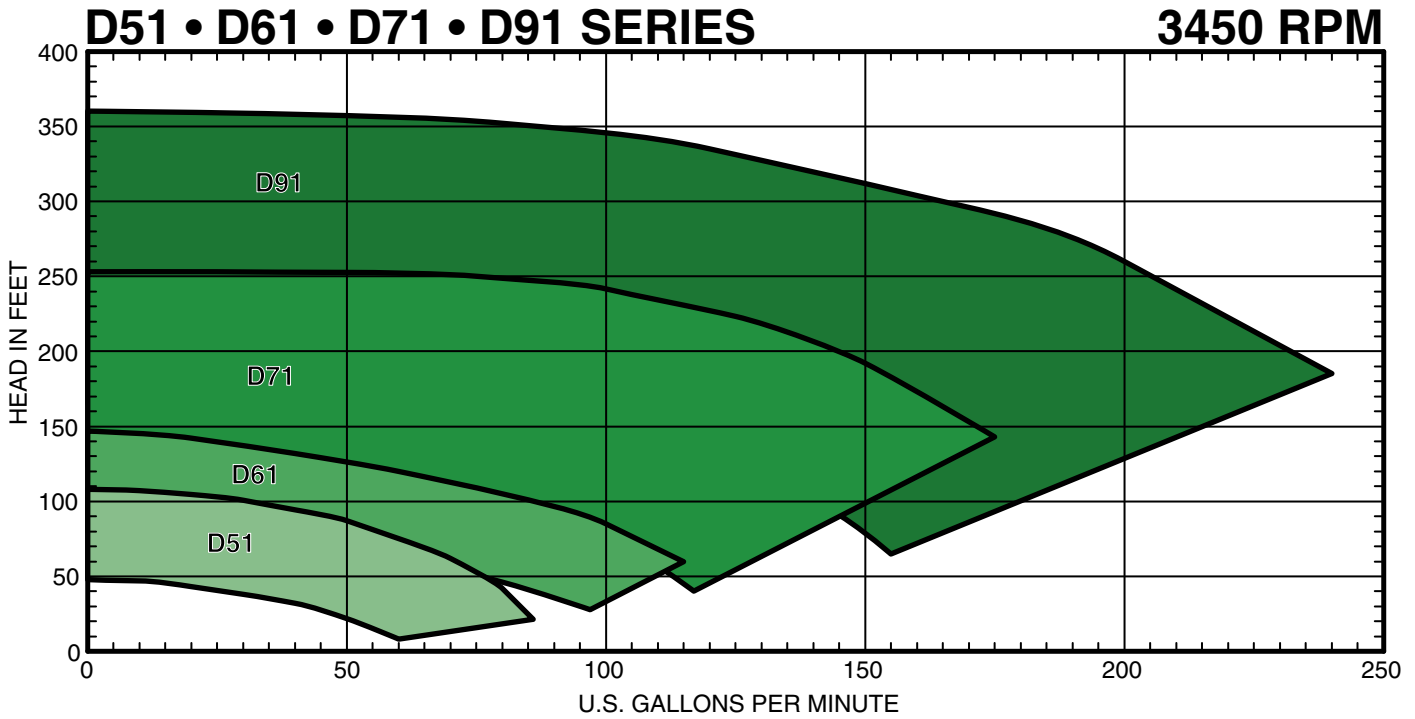

MTH PUMPS

401 West Main Street • Plano, IL 60545-1436
Phone: 630-552-4115 • Fax: 630-552-3688
Email: SALES@MTHPUMPS.COM
<http://WWW.MTHPUMPS.COM>