

Condensate Units (Built to Order, continued)

Series PCC™ & PCS™ Pumpless Condensate Units

Series PCC and PCS Pumpless Condensate Units are designed for applications in remote areas and/or hazardous environments where transferring condensate to or from condensers, turbines, and other steam condensing equipment without using electricity, is necessary.

- Handles condensate at saturation temperature
- Cast iron or fabricated steel body
- ASME stamped PCC 6 and PCS 8 units
- Includes water level gauge with protective brass rods and shut-off valves
- Includes bronze swing inlet and outlet check valves
- Optional equipment
 - Cycle counter
 - Stainless steel check valves
 - Insulation
 - Packaged units with receiver



Series PCC



Series PCS

Series PCS

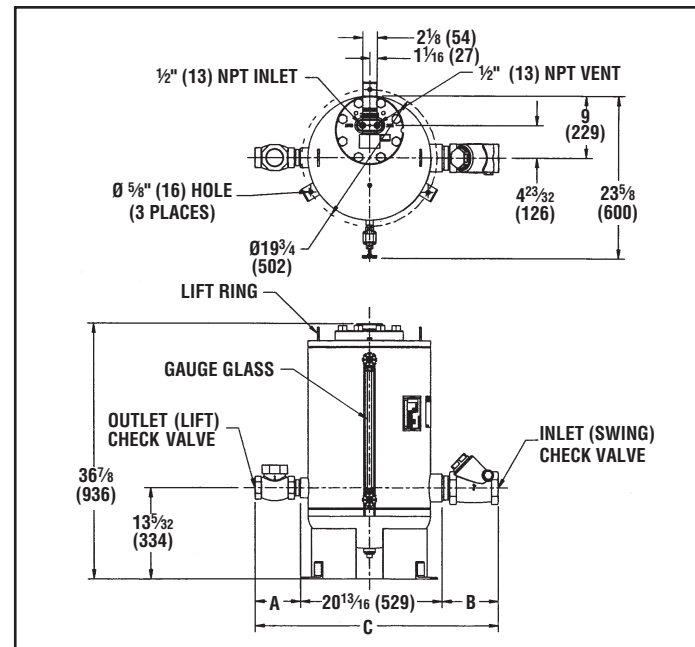

Series PCS Dimensions, in. (mm)

Model No.	Size	A	B*	C*	Wt. Lbs. (Kg)
PCS8-2	2 X 2	6 3/4 (171)	6 7/8 (175)	34 7/16 (875)	302 (137)
PCS8-3	3 X 2	6 3/4 (171)	8 1/2 (216)	36 7/16 (916)	315 (143)

* Check valves are standard equipment but require installation by customer. This dimension is for check valves installed with close nipples approximately 2" long.

NOTE: To achieve rated capacity, pump must be installed with check valves as supplied by ITT Domestic. Use of substitute check valve may alter the performance of the pump.

Series PCC

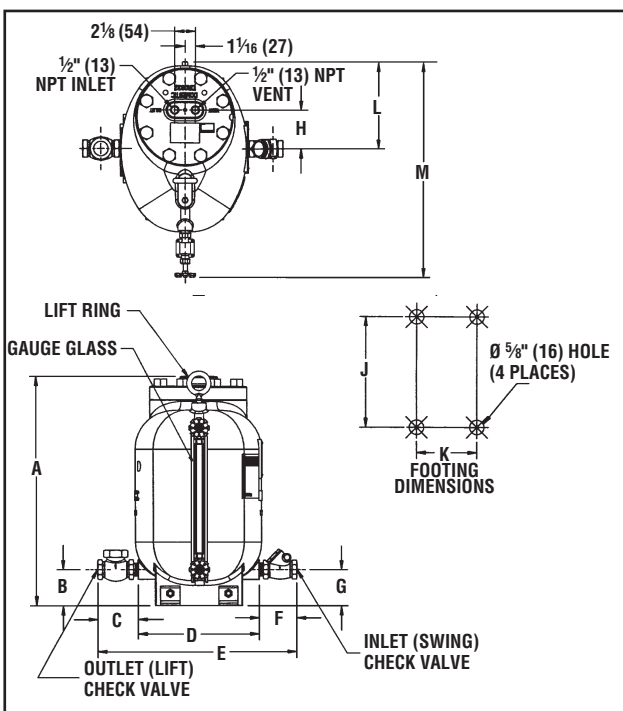

Series PCC Dimensions, in. (mm)

Model No.	Size	A	B	C*	D	E*	F*	G	H	J	K	L	M	Wt. Lbs. (Kg)
PCC4-1	1 X 1	23 1/2 (597)	3 1/16 (94)	4 (102)	12 1/2 (318)	20 1/2 (521)	4 (102)	3 1/16 (94)	3 31/32 (101)	12 3/8 (314)	6 (152)	9 (229)	22 1/2 (572)	207 (94)
PCC6-1	1 X 1	25 1/2 (648)	4 3/4 (121)	5 1/8 (130)	16 1/2 (419)	26 1/2 (673)	4 7/8 (124)	4 3/4 (121)	4 31/32 (126)	12 3/8 (314)	6 (152)	10 1/8 (257)	24 3/8 (619)	337 (153)
PCC6-1.5	1.5 X 1.5	25 1/2 (648)	4 3/4 (121)	6 3/8 (162)	16 1/2 (419)	28 7/8 (733)	6 (152)	4 3/4 (121)	4 31/32 (126)	12 3/8 (314)	6 (152)	10 1/8 (257)	24 3/8 (619)	346 (157)
PCC6-2	2 X 2	25 1/2 (648)	4 3/4 (121)	6 3/4 (173)	16 1/2 (419)	29 3/8 (746)	6 1/8 (156)	4 3/4 (121)	4 31/32 (126)	12 3/8 (314)	6 (152)	10 1/8 (257)	24 3/8 (619)	358 (162)

* Check valves are standard equipment but require installation by customer. This dimension is for check valves installed with close nipples approximately 2" long.

NOTE: To achieve rated capacity, pump must be installed with check valves as supplied by ITT Domestic. Use of substitute check valve may alter the performance of the pump.

* Contact your Hoffman representative for sizing details.

How to Select Series PCC Pumpless Condensate Units

SELECTION

When sizing a Domestic Pumpless Condensate Transfer Unit, five system conditions are needed.

1. Condensate Load _____ lbs./hr.
2. Steam or air pressure available for operating pump _____ psig.
3. Vertical lift (Back Pressure) _____ ft.
4. Pressure drop in the return piping _____ ft.
5. Filling head available _____ inches. (See page 5, Typical Application)

EXAMPLE:

1. Condensate Load 6300 lb./hr.
2. Steam/Gas available (motive pressure) 100 psig
3. Vertical Lift (back pressure) 86 feet
4. Pressure drop in return piping 2 feet
5. Filling head available 12 inches

TO SOLVE:

1. Calculate "H" back pressure, $H = (86 + 2) \div 2.31 = 38$ psig
2. From the capacity table below, with 100 psig inlet pressure & 38 psig back pressure, choose PCC 6 1.5" x 1.5" which has 1 1/2" inlet/outlet check valves (100 psig motive, 40 psig back pressure). Capacity of PCC 6 1.5 x 1.5 is 6500 lb./hr.

Capacities for Steam (lbs./hr.)

When installed with recommended 12" (305mm) filling head measured from top of pump

Operating Inlet Pressure		Total Lift or Back Pressure		Filling Head 12" Liquid Specific Gravity 0.9 to 1 Check Valve and Pipe Sizing (NPT)											
				PCC4		PCC6				PCS8					
				1" (25 mm)		1" (25 mm)		1 1/2" (40 mm)		2" (50 mm)		2" (50 mm)		3" x 2" (80 mm X 50 mm)	
PSIG	kPa	PSIG	kPa	Lbs/Hr	Kg/Hr	Lbs/Hr	Kg/Hr	Lbs/Hr	Kg/Hr	Lbs/Hr	Kg/Hr	Lbs/Hr	Kg/Hr	Lbs/Hr	Kg/Hr
150	1034	15	103			4100	1860	8600	3901	10700	4854	10700	4854	11000	4990
150	1034	25	172			3885	1762	8200	3720	9700	4400	9800	4445	9800	4445
150	1034	40	276			3680	1669	7350	3334	8200	3720	8200	3720	8600	3901
150	1034	60	414			3300	1497	6300	2858	6800	3084	6800	3084	7400	3357
150	1034	80	552			2940	1334	5300	2404	6000	2722	6000	2722	6400	2903
150	1034	100	690			2630	1193	4300	1950	5200	2359	5200	2359	5400	2449
125	862	15	103	3700	1678	3900	1769	8500	3856	10500	4763	10500	4763	10700	4854
125	862	25	172	3500	1588	3700	1678	7800	3538	8600	3901	9200	4173	9400	4264
125	862	40	276	3200	1452	3360	1524	6800	3084	7500	3402	7600	3447	7800	3538
125	862	60	414	2900	1315	3050	1383	5600	2540	6600	2994	6600	2994	6800	3084
125	862	80	552	2600	1179	2730	1238	4700	2132	5400	2449	5400	2449	5400	2449
125	862	100	690	2200	998	2310	1048	3300	1497	3400	1542	3500	1588	3500	1588
100	690	15	103	3700	1678	3780	1715	8200	3720	9000	4082	10000	4536	10300	4672
100	690	25	172	3500	1588	3570	1619	7500	3402	8250	3742	8800	3992	8900	4037
100	690	40	276	3100	1406	3255	1476	6500	2948	7300	3311	7300	3311	7700	3493
100	690	60	414	2700	1225	2835	1286	5400	2449	5600	2540	5600	2540	5700	2586
100	690	80	552	2275	1032	2400	1089	3300	1497	3800	1724	3800	1724	4000	1814
75	517	15	103	3500	1588	3700	1678	7800	3538	8700	3946	9200	4173	9300	4218
75	517	25	172	3100	1406	3260	1479	7200	3266	7550	3425	7800	3538	8000	3629
75	517	40	276	2600	1179	2700	1225	6000	2722	6400	2903	6400	2903	6400	2903
75	517	60	414	2000	907	2100	953	3600	1633	3800	1724	4000	1814	4200	1905
50	345	15	103	3100	1406	3300	1497	6600	2994	8400	3810	8400	3810	8500	3856
50	345	25	172	2550	1157	2700	1225	5400	2449	6600	2994	6700	3039	6800	3084
50	345	40	276	1900	862	2000	907	3000	1361	3750	1701	4000	1814	4300	1950
25	172	5	34	2600	1179	2700	1225	6500	2948	7200	3266	7200	3266	7400	3357
25	172	15	103	2000	907	2100	953	3400	1542	4100	1860	4100	1860	4200	1905
10	69	2	14	2300	1043	2400	1089	3000	1361	5000	2268	5800	2631	6400	2903
10	69	5	34	1200	544	1500	680	2000	907	2300	1043	2500	1134	2600	1179

Factors for Other Filling Heads					
Filling Head		Capacity Multiplying Factors Check Valve and Piping Size			
		1" (25 mm)	1.5" (38 mm)	2" (51 mm)	3" X 2" (76 mm x 51 mm)
6	152	0.85	0.85	0.85	0.95
12	305	1.0	1.0	1.0	1.0
24	610	1.15	1.05	1.15	1.1

Example: From capacity factor charts, pump capacity if filling head is 24": 1.05 x 6500 lbs/hr = 6825 lbs/hr.

Capacity Multiplying Factors for Motive Gas Supplies (other than steam)									
1" through 3" X 2" Check Valve Size									
% Backpressure vs. Motive Pressure (BP/MP)	10%	20%	30%	40%	50%	60%	70%	80%	90%
Capacity Multiplying Factors	1.02	1.04	1.06	1.08	1.1	1.15	1.28	1.46	1.28

Example: Using air as a motive force. 100 psig motive pressure and 40 psig back pressure, $40 \div 100 = 40\%$. Multiply unit capacity shown in capacity table, 6500 lbs/hr by 1.08 to obtain unit rating. $6500 \times 1.08 = 7020$ lbs/hr.

Typical Application

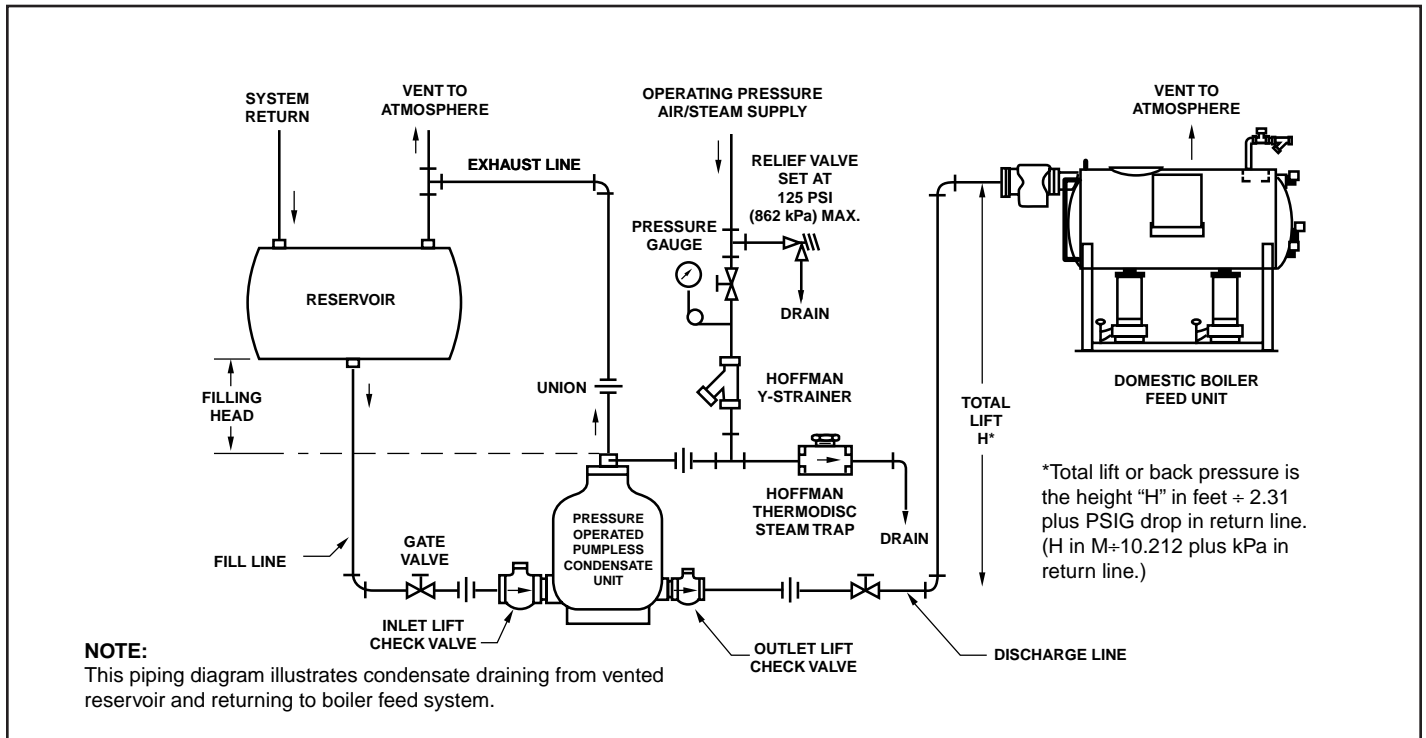

Operation

At start-up, the float is at its lowest position (B) with the exhaust valve open and inlet valve closed. As condensate drains into the unit through the inlet check valving filling the unit, the float begins to rise. The float continues to rise until it reaches its upper tripping position (A). At this point, the spring loaded mechanism snaps over the center, which moves the actuator rod upwards causing the inlet valve to open and the exhaust valve to close. Steam or air now enters through the inlet valve pressuring the body forcing the condensate out through the outlet check valve. The inlet check valve is held closed by the pressure in the body. As condensate is pumped out through the check valve, the float outlet drops until it reaches its lower tripping position (B). At this point the mechanism reverses and closes the inlet valve and opens the exhaust valve completing the cycle. This cycle repeats itself as condensate beings to fill the unit again.

Filling sequence begins at float position "B"

1. Steam/air inlet closed
2. Exhaust outlet open
3. Inlet check open
4. Outlet check closed

Pumping sequence begins at float position "A"

1. Steam/air inlet open
2. Exhaust outlet closed
3. Inlet check closed
4. Outlet check open

