

Model HSG

200/400 GAS BURNER

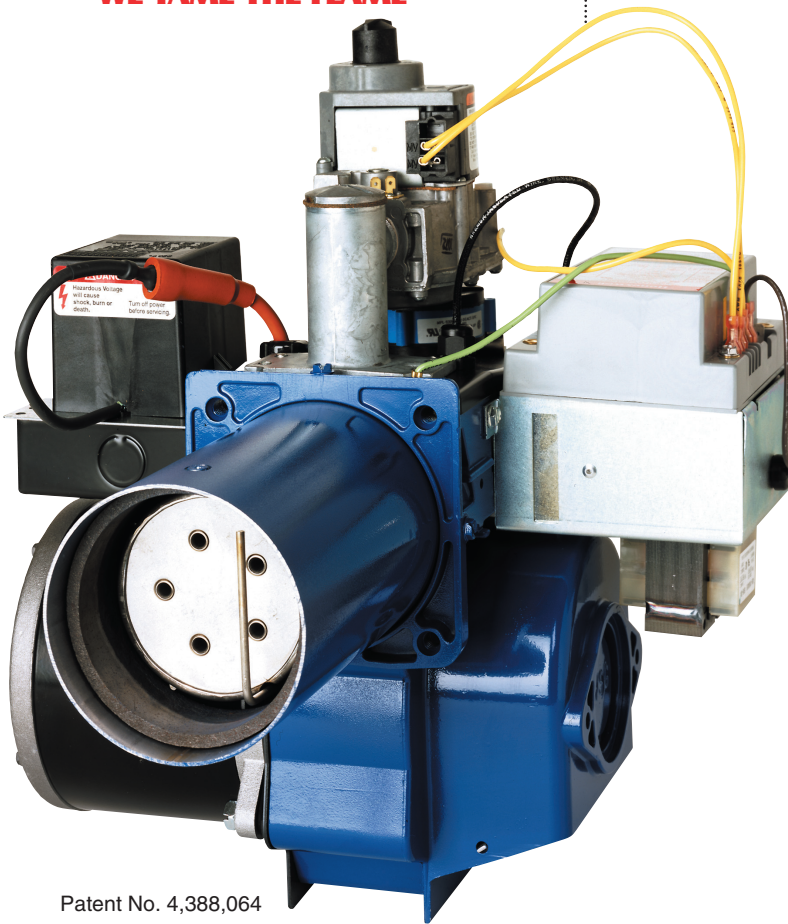

WE TAME THE FLAME



Patent No. 4,388,064

BA
BLUE ANGELTM PLUS

HSG features:

The Wayne Model HSG power gas burners are designed for performance and reliability, and offer features such as:

- Higher static air pressure than standard power gas burners
- Good combustion in poor draft situations
- Capability to fire LP or Natural Gas
- Flame retention head to allow flame shapes to fit various combustion chambers
- Positive premixing of gas and air to provide excellent combustion characteristics (9 to 11% CO₂ on Natural Gas)

Designed For Easy Serviceability:

- No need to remove the burner for normal service – “Gas Gun” assembly is easily removed for complete service or replacement of components
- Easy, external orifice change
- Automatic, perfect alignment of combustion components
- Primary air adjustment with indicator

Designed For Installation Flexibility:

- Just change the orifice and adjust to fire LP or Natural Gas through the full burner range from 60M to 200M Btu/hr and 200M to 400M Btu/hr
- Complete range of marked orifice sizes supplied with each HSG burner
- Primary air inlet designed for optional outside air intake
- Industry proven components for excellent performance and reliability
- Automatic off-cycle air damper to minimize efficiency loss and provide maximum installation flexibility

Specifications

200/400 GAS BURNER

HSG 200 - 60M Btu/hr to 200M Btu/hr
HSG 400 - 200M Btu/hr to 400M Btu/hr

THE BLUE ANGEL™ POWER GAS BURNER - MODEL HSG

Capacities	Firing rates from 60M through 400M Btu/hr.
Fuel	Natural or LP Gas 2" to 4" water column - adjustable.
Controls	24-volt combination control 3/4" IPS, with redundant valve. Flamerod sensor 4 second safety shutdown.
Ignition	Direct spark ignition 7300-volt ignition transformer. Remove top cover for easy access to ignition components.
Motor	3450 RPM – 115V – 2.4A.
Fan Housing	Aluminum alloy, die cast housing. Maintains alignment of all moving parts throughout the lifetime of the burner.
Mounting	Adjustable flange (pedestal mount available.)
Air Tube	4" OD available in standard lengths of 6", 9" and 12".
Combustion Head	Stainless steel, precision stamping. No change for entire firing range.

DIMENSIONS

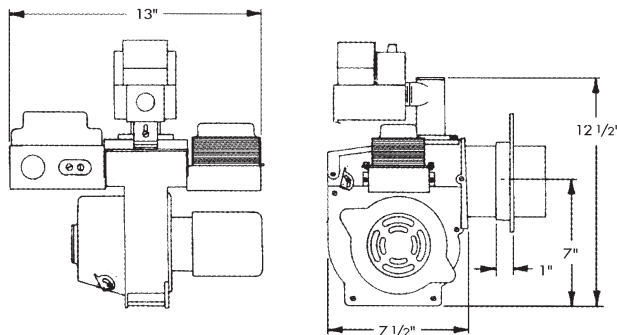

MOUNTINGS

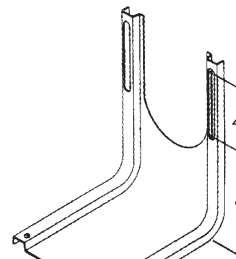

PEDESTAL ASSEMBLY

Complete Burner:

All BLUE ANGEL Model HSG flame retention gas burners are supplied completely assembled and testfired. Additional orifices supplied. Combination redundant gas valve and ignition control package installed. The models at right include an adjustable flange with gasket as standard and are available for immediate shipment.

Shipping Information:

- Individually cartoned
- Weight: 26 lbs.
- 18 burners per pallet

ORDERING INFORMATION

Part No.	Model No.	Tube Length	Capacity - M Btu/hr
62376C	HSG 200	6"	60-200
62377C	HSG 400	6"	200-400
62378C	HSG 200	9"	60-200
62379C	HSG 400	9"	200-400
62380C	HSG 200	12"	60-200
62381C	HSG 400	12"	200-400

