

"QUALITY PUMPS SINCE 1939"

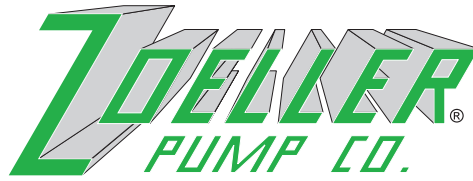

SECTION: 3.10.005
FM2124
0103
Supersedes
1202

Product information presented here reflects conditions at time of publication. Consult factory regarding discrepancies or inconsistencies.

MAIL TO: P.O. BOX 16347 • Louisville, KY 40256-0347
SHIP TO: 3649 Cane Run Road • Louisville, KY 40211-1961
(502) 778-2731 • 1 (800) 928-PUMP • FAX (502) 774-3624

visit our web site:
<http://www.zoeller.com>

PREASSEMBLED SUMP PUMP SYSTEMS

900 SERIES

Job ready for a fast and easy installation.
No assembly required - Drop it in the hole-and-go!

900 SUMP PUMP SERIES INCLUDES:

Preassembled:

- Pump switch is installed 180° from inlet.
- Discharge pipe is plumbed with a predrilled 3/16" vent hole.
- Electrical cord seal is installed in cover.
- Cover is sealed and bolted down.
- Basin is filled with environmentally safe peanuts for safe transit - just add water and they dissolve!
- Automatic cast iron or thermoplastic pump with tank and all hardware.
- 18" X 22" basin with 4" inlet.
- Deluxe unit has a Radon approved basin and cover for Radon prevention.
- Standard and economy models use a polyethylene basin and cover.
- Deluxe cover has a 3" vent, 1 1/2" discharge.
- Standard and economy covers have a 2" vent, 1 1/2" discharge.
- Fast, easy and job ready!

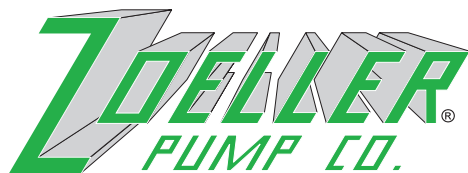

Manufacturers of . . .

"QUALITY PUMPS SINCE 1939"

SUMP PUMP SERIES	MODEL PUMP WITH BASIN	SYSTEM TYPE	SYSTEM WEIGHT
900-0001	M53	DELUXE	48 LBS.
900-0002	M53	STANDARD	53 LBS.
900-0003	M72	ECONOMY	44 LBS.

COMPARE THESE FEATURES



DELUXE & STANDARD SYSTEMS

(Model M53 Pump)

- Automatic, float operated mechanical switch.
- 115 V/1 Ph., 60 Hz.
- 9 ft. UL Listed 3-wire cord and plug.
- Stainless steel screws, guard, handle and switch arm.
- Passes 1/2" spherical solids.
- 1 1/2" NPT discharge.
- 1550 RPM.
- Non-clogging vortex impeller.
- Glass-filled polypropylene base with built-in strainer.
- Temperature rated 130° F.
- UL and CSA Listed Pump.

ECONOMY SYSTEM

(Model M72 Pump)

- 115 V/1 Ph., 60 Hz.
- 9 ft. UL Listed 3-wire cord and plug.
- Stainless steel screws, switch arm and lower motor housing.
- Oil free.
- Passes 3/8" spherical solids.
- 1 1/2" NPT discharge.
- 3400 RPM.
- Non-clogging vortex impeller.
- Temperature rated 110° F.
- cCSAus Certified Pump.

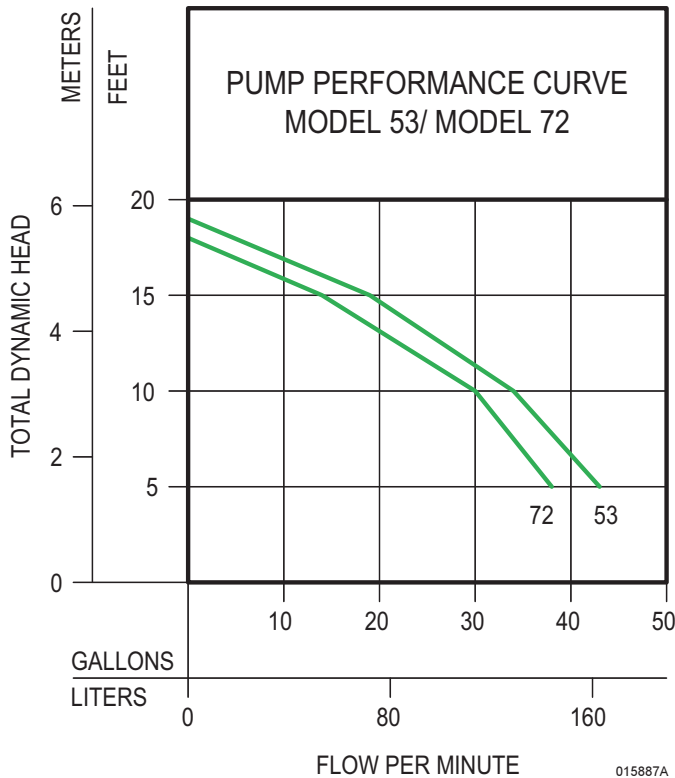
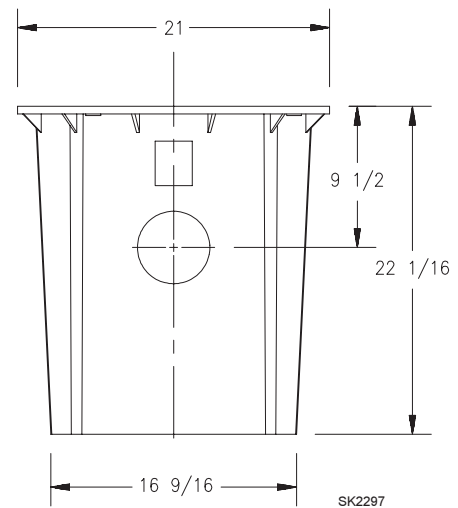
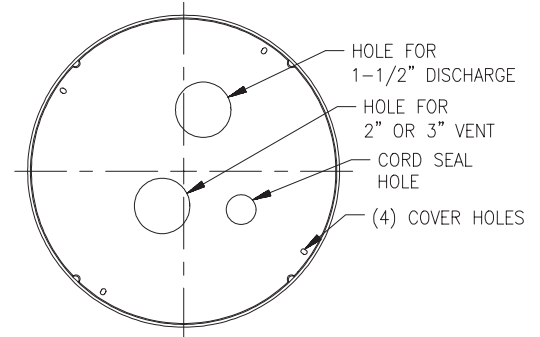

TOTAL DYNAMIC HEAD/FLOW PER MINUTE EFFLUENT AND DEWATERING

MODEL		53		72	
Feet	Meters	Gal.	Liters	Gal.	Liters
5	1.5	43	163	38	144
10	3.0	34	129	30	114
15	4.6	19	72	14	53
Shut-off Head:		19.25 ft.(5.9 m)		18 ft.(5.5 m)	

015887B

JOB READY FOR EASY INSTALLATION



WARNING TO REDUCE THE RISK OF ELECTRICAL SHOCK A PROPERLY GROUNDED RECEPTACLE OF GROUNDING TYPE SHALL BE INSTALLED AND PROTECTED BY A GROUND FAULT CIRCUIT INTERRUPTER (GFCI) IN ACCORDANCE WITH NATIONAL ELECTRICAL CODE AND LOCAL CODES. DO NOT REMOVE GROUND PIN FROM PLUG.

RESERVE POWERED DESIGN

For unusual conditions a reserve safety factor is engineered into the design of every Zoeller pump.