



Product information presented here reflects conditions at time of publication. Consult factory regarding discrepancies or inconsistencies.

MAIL TO: P.O. BOX 16347 • Louisville, KY 40256-0347  
SHIP TO: 3649 Cane Run Road • Louisville, KY 40211-1961  
(502) 778-2731 • 1 (800) 928-PUMP • FAX (502) 774-3624

visit our web site:  
[www.zoeller.com](http://www.zoeller.com)

## REPLACEMENT PARTS LIST FOR MODELS:

- E4405 NONAUTOMATIC/DOUBLE SEAL/230V/1PH
- WD4405 AUTOMATIC w/wired in float switch/DOUBLE SEAL/230V/1PH
- XE4405 NONAUTOMATIC/remote pilot/ DOUBLE SEAL/230V/1PH
- I4405 NONAUTOMATIC/DOUBLE SEAL/200V/1PH
- J4405 NONAUTOMATIC/DOUBLE SEAL/200V/3PH
- F4405 NONAUTOMATIC/DOUBLE SEAL/230V/3PH
- G4405 NONAUTOMATIC/DOUBLE SEAL/460V/3PH
- BA4405 NONAUTOMATIC/DOUBLE SEAL/575V/3PH

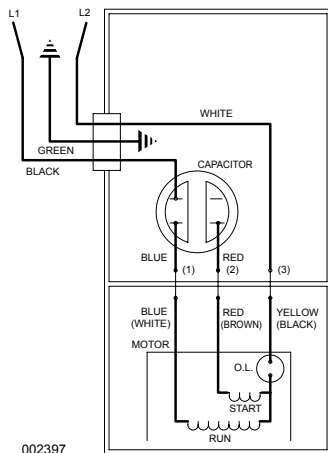

002397  
WIRING DIAGRAM FOR MODELS  
E4405 AND I4405  
ALL REVISIONS

Consult factory for all other models

### TO ORDER REPLACEMENT PARTS:

#### PLEASE FURNISH THE FOLLOWING INFORMATION:

- Model Number.
- Part Number of Pump.
- Part Number and Description of part.

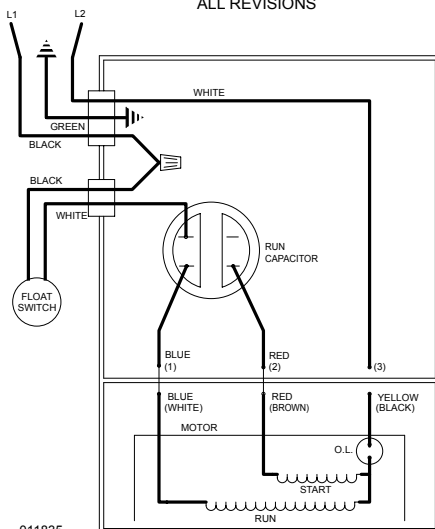

011835  
WIRING DIAGRAM FOR MODELS WD4405  
ALL REVISIONS

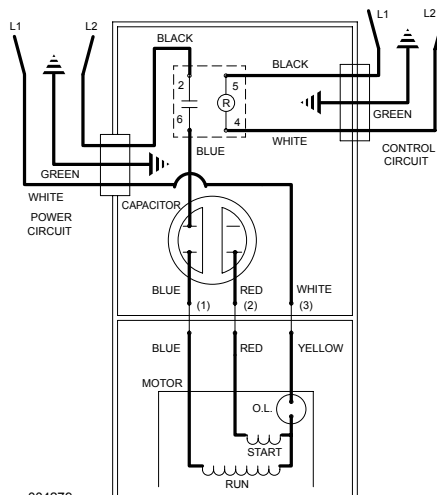

004279  
WIRING DIAGRAM FOR MODELS XE4405  
ALL REVISIONS

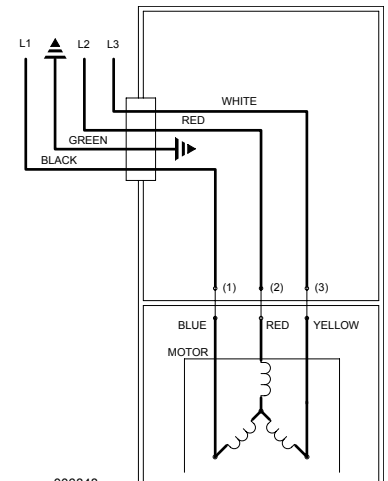

006848  
WIRING DIAGRAM FOR MODELS  
J4405, F4405, G4405 AND BA4405  
ALL REVISIONS

# REPLACEMENT PARTS LIST FOR MODEL "E4405".

See back page for illustration.

REF NO.	DESCRIPTION	QTY	NOTES	MODELS:			
				E4405-A	E4405-B	E4405-C	E4405-D
				1/94 thru 10/97	11/97 thru 6/98	7/98 thru 4/03	5/03 thru Current
1	COVER & CORD ASM.	1	3	006098	006098	012463	014162
2	BOLT, EYE	1		005926	005926	N/A	N/A
3	COVER-MACH.	1	3	005864	005864	004372	014150
4	• GASKET,CASE/COVER	1		001011	001011	001011	001011
5	RELAY, 230V	0		N/A	N/A	N/A	N/A
6	• WIRE PKG (5) WIRES 1.5/2 HP	1		004751	004751	004751	004751
7	CAPACITOR & CLAMP ASM.	1		002381	010666	010666	010666
8	HOUSING, MTR. & STR.	1	1 & 2	006097	006097	006097	006097
9	BEARING, SLEEVE	1		001012	001012	001012	001012
10	• PLUG, TEST-WHITE	3		034090	034090	034090	034090
11	• SEAL, THRU WALL TERM.	3		003402	003402	003402	003402
12	ROTOR & BRG.	1	2	012192	012192	012192	012192
13	• BEARING, RADIAL	1		001013	001013	001013	001013
14	• SEAL, MTR HSG.	2		001014	001014	001014	001014
15	• OIL, DIELECTRIC-(44 OZ)	1		003168	003168	003168	003168
16	ADAPTER-MACH.	1		008862	008862	008862	008862
17	• WASHER, SEAL LOCATING & SNAP RING	1		011057	011057	011057	011057
18	• SEAL, SHAFT	2		002430	002430	002430	002430
19	ADAPTER-MACH. LOWER	1		008833	008833	008833	008833
20	IMPELLER ASM.	1		007671	007671	007671	007671
21	• KEY, WOODRUFF #404	1		006841	006841	006841	006841
22	• WASHER, 7/16 STD FLAT SS	1		006847	006847	006847	006847
23	• NUT, 7/16-20 SS HEX	1		006846	006846	006846	006846
24	HOUSING, PUMP-MACH.	1		005711	005711	011784	011784
25	CORD TERM. & SEAL POWER	1	3	004376	004376	004376	014175
26	• SEAL, CORD-ASM. & STR. RLF.	1	3	004375	004375	004375	015634
27	CLAMP, STRAIN RELIEF/2EAR.563/ZINC PL STL	1		N/A	N/A	N/A	013764
28	CLAMP, #6 AUTO-SS	0		N/A	N/A	N/A	N/A
29	CORD, TERM. & SEAL CONTROL	0		N/A	N/A	N/A	N/A
30	• SEAL, CORD-ASM & STR. RLF. CONTROL CORD	0		N/A	N/A	N/A	N/A
31	CLAMP, STR. RLF.	0		N/A	N/A	N/A	N/A
32	• SCREW, #6-32X.25 RHM SL TC STLGR.	3		001877	001877	001877	001877
33	SWITCH, FLT-TERM. & SEAL	0		N/A	N/A	N/A	N/A
34	SEAL, CORD-ASM. & STRAIN RELIEF	0		N/A	N/A	N/A	N/A
35	CONNECTOR, WIRENUT	0		N/A	N/A	N/A	N/A
36	• SCREW, .25-20X.75 HHM-SS	4		001916	001916	001916	001916
37	• SCREW, .25-20X1" HHM-SS	4		007790	007790	007790	007790
38	• SCREW, .313-18 X 1"HH CAP-SS	10		002608	002608	002608	002608
39	• WASHER, LOCK SS .312 ID	2		N/A	N/A	006402	006402
40	BRACKET, LIFTING	1		N/A	N/A	010589	016801
41	RESISTOR ASSEMBLY	0		N/A	N/A	N/A	N/A
42	SENSOR WIRES	0		N/A	N/A	N/A	N/A
43	SENSOR CORDAGE TERM. & SEAL	0		N/A	N/A	N/A	N/A
44	SEAL, CORD-ASM. STR. RLF.	0		N/A	N/A	N/A	N/A
45	• WASHER, FLAT SS	2		N/A	N/A	N/A	008773
▣	REBUILD KIT	1		012196	011334	012380	016805

• Items included in Rebuild Kit.

▣ Not Shown in Illustration.

## NOTES:

- 1) Mtr. Hsg., Brg., Stator & Term (Item 8) are preassembled at the factory and must be replaced as a unit. Stator is permanently attached to the Motor Housing. Plug (Item 10); Seal, Thru Wall Term. (Item 11) and Bearing - Upper (Item 9) are replaceable.
- 2) When ordering Motor Housing, Bearing, Stator and Term. (item 8); or Rotor and Bearing (Item 12), specify either GE or Emerson motor.
- 3) If an "X" follows Model No., or Date Mfg. on brass I.D. tag, consult factory for ordering of this part.
- 4) See FM0160 Parts Price Sheet for listing of parts prices.

© Copyright 2006 Zoeller Co. All rights reserved.

# REPLACEMENT PARTS LIST FOR MODEL "I4405".

See back page for illustration.

				MODELS:		
REF NO.	DESCRIPTION	QTY	NOTES	I4405-A	I4405-B	I4405-C
				2/89 thru 6/98	7/98 thru 4/03	5/03 thru Current
1	COVER & CORD ASM.	1	3	012191	012468	014159
2	BOLT, EYE	1		005926	N/A	N/A
3	COVER-MACH.	1	3	005864	004372	014150
4	• GASKET,CASE/COVER	1		001011	001011	001011
5	RELAY, 230V	0		N/A	N/A	N/A
6	• WIRE PKG (5) WIRES 1.5/2 HP	1		004751	004751	004751
7	CAPACITOR & CLAMP ASM.	1		010666	010666	010666
8	HOUSING, MTR. & STR.	1	1 & 2	007808	007808	007808
9	BEARING, SLEEVE	1		001012	001012	001012
10	• PLUG, TEST-WHITE	3		034090	034090	034090
11	• SEAL, THRU WALL TERM.	3		003402	003402	003402
12	ROTOR & BRG.	1	2	012192	012192	012192
13	• BEARING, RADIAL	1		001013	001013	001013
14	• SEAL, MTR HSG.	2		001014	001014	001014
15	• OIL, DIELECTRIC-(44 OZ)	1		003168	003168	003168
16	ADAPTER-MACH.	1		008862	008862	008862
17	• WASHER, SEAL LOCATING & SNAP RING	1		011057	011057	011057
18	• SEAL, SHAFT	2		002430	002430	002430
19	ADAPTER-MACH. LOWER	1		008833	008833	008833
20	IMPELLER ASM.	1		007671	007671	007671
21	• KEY, WOODRUFF #404	1		006841	006841	006841
22	• WASHER, 7/16 STD FLAT SS	1		006847	006847	006847
23	• NUT, 7/16-20 SS HEX	1		006846	006846	006846
24	HOUSING, PUMP-MACH.	1		005711	011784	011784
25	CORD TERM. & SEAL POWER	1	3	009685	009685	014173
26	• SEAL, CORD-ASM. & STR. RLF.	1	3	004375	004375	015634
27	CLAMP, STRAIN RELIEF/2EAR.563/ZINC PL STL	1		N/A	N/A	013764
28	CLAMP, #6 AUTO-SS	0		N/A	N/A	N/A
29	CORD, TERM. & SEAL CONTROL	0		N/A	N/A	N/A
30	• SEAL, CORD-ASM & STR. RLF. CONTROL CORD	0		N/A	N/A	N/A
31	CLAMP, STR. RLF.	0		N/A	N/A	N/A
32	• SCREW, #6-32X.25 RHM SL TC STLGR.	3		001877	001877	001877
33	SWITCH, FLT-TERM. & SEAL	0		N/A	N/A	N/A
34	SEAL, CORD-ASM. & STRAIN RELIEF	0		N/A	N/A	N/A
35	CONNECTOR, WIRENUT	0		N/A	N/A	N/A
36	• SCREW, .25-20X.75 HHM-SS	4		001916	001916	001916
37	• SCREW, .25-20X1" HHM-SS	4		007790	007790	007790
38	• SCREW, .313-18 X 1"HH CAP-SS	10		002608	002608	002608
39	• WASHER, LOCK SS .312 ID	2		N/A	006402	006402
40	BRACKET, LIFTING	1		N/A	010589	016801
41	RESISTOR ASSEMBLY	0		N/A	N/A	N/A
42	SENSOR WIRES	0		N/A	N/A	N/A
43	SENSOR CORDAGE TERM. & SEAL	0		N/A	N/A	N/A
44	SEAL, CORD-ASM. STR. RLF.	0		N/A	N/A	N/A
45	• WASHER, FLAT SS	2		N/A	N/A	008773
▣	REBUILD KIT	1		012196	012380	016805

• Items included in Rebuild Kit.

▣ Not Shown in Illustration.

## NOTES:

- 1) Mtr. Hsg., Brg., Stator & Term (Item 8) are preassembled at the factory and must be replaced as a unit. Stator is permanently attached to the Motor Housing. Plug (Item 10); Seal, Thru Wall Term. (Item 11) and Bearing - Upper (Item 9) are replaceable.
- 2) When ordering Motor Housing, Bearing, Stator and Term. (Item 8); or Rotor and Bearing (Item 12), specify either GE or Emerson motor.
- 3) If an "X" follows Model No., or Date Mfg. on brass I.D. tag, consult factory for ordering of this part.
- 4) See FM0160 Parts Price Sheet for listing of parts prices.

© Copyright 2006 Zoeller Co. All rights reserved.

# REPLACEMENT PARTS LIST FOR MODEL "WD4405".

See back page for illustration.

REF NO.	DESCRIPTION	QTY	NOTES	MODELS:		
				WD4405-A	WD4405-B	WD4405-C
				2/98 thru 6/98	7/98 thru 4/03	5/03 thru Current
1	COVER & CORD ASM.	1	3	011875	012467	016113
2	BOLT, EYE	1		005926	N/A	N/A
3	COVER-MACH.	1	3	008860	008857	014152
4	• GASKET,CASE/COVER	1		001011	001011	001011
5	RELAY, 230V	0		N/A	N/A	N/A
6	• WIRE PKG (5) WIRES 1.5/2 HP	1		004751	004751	004751
7	CAPACITOR & CLAMP ASM.	1		010666	010666	010666
8	HOUSING, MTR. & STR.	1	1 & 2	006097	006097	006097
9	BEARING, SLEEVE	1		001012	001012	001012
10	• PLUG, TEST-WHITE	3		034090	034090	034090
11	• SEAL, THRU WALL TERM.	3		003402	003402	003402
12	ROTOR & BRG.	1	2	012192	012192	012192
13	• BEARING, RADIAL	1		001013	001013	001013
14	• SEAL, MTR HSG.	2		001014	001014	001014
15	• OIL, DIELECTRIC-(44 OZ)	1		003168	003168	003168
16	ADAPTER-MACH.	1		008862	008862	008862
17	• WASHER, SEAL LOCATING & SNAP RING	1		011057	011057	011057
18	• SEAL, SHAFT	2		002430	002430	002430
19	ADAPTER-MACH. LOWER	1		008833	008833	008833
20	IMPELLER ASM.	1		007671	007671	007671
21	• KEY, WOODRUFF #404	1		006841	006841	006841
22	• WASHER, 7/16 STD FLAT SS	1		006847	006847	006847
23	• NUT, 7/16-20 SS HEX	1		006846	006846	006846
24	HOUSING, PUMP-MACH.	1		005711	011784	011784
25	CORD TERM. & SEAL POWER	1	3	010828	010828	016115
26	• SEAL, CORD-ASM. & STR. RLF.	1	3	004375	004375	015634
27	CLAMP, STRAIN RELIEF/2EAR.563/ZINC PL STL	1		N/A	N/A	013764
28	CLAMP, #6 AUTO-SS	0		N/A	N/A	N/A
29	CORD, TERM. & SEAL CONTROL	0		N/A	N/A	N/A
30	• SEAL, CORD-ASM & STR. RLF. CONTROL CORD	0		N/A	N/A	N/A
31	CLAMP, STR. RLF.	0		N/A	N/A	N/A
32	• SCREW, #6-32X.25 RHM SL TC STLGR.	3		001877	001877	001877
33	SWITCH, FLT-TERM. & SEAL	1		011876	011876	011878
34	SEAL, CORD-ASM. & STRAIN RELIEF	1		094032	094032	094032
35	CONNECTOR, WIRENUT	1		011868	011868	011868
36	• SCREW, .25-20X.75 HHM-SS	4		001916	001916	001916
37	• SCREW, .25-20X1" HHM-SS	4		007790	007790	007790
38	• SCREW, .313-18 X 1"HH CAP-SS	10		002608	002608	002608
39	• WASHER, LOCK SS .312 ID	2		N/A	006402	006402
40	BRACKET, LIFTING	1		N/A	010589	016801
41	RESISTOR ASSEMBLY	0		N/A	N/A	N/A
42	SENSOR WIRES	0		N/A	N/A	N/A
43	SENSOR CORDAGE TERM. & SEAL	0		N/A	N/A	N/A
44	SEAL, CORD-ASM. STR. RLF.	0		N/A	N/A	N/A
45	• WASHER, FLAT SS	2		N/A	N/A	008773
▣	REBUILD KIT	1		012212	012383	016805

• Items included in Rebuild Kit.

▣ Not Shown in Illustration.

## NOTES:

- 1) Mtr. Hsg., Brg., Stator & Term (Item 8) are preassembled at the factory and must be replaced as a unit. Stator is permanently attached to the Motor Housing. Plug (Item 10); Seal, Thru Wall Term. (Item 11) and Bearing - Upper (Item 9) are replaceable.
- 2) When ordering Motor Housing, Bearing, Stator and Term. (Item 8); or Rotor and Bearing (Item 12), specify either GE or Emerson motor.
- 3) If an "X" follows Model No., or Date Mfg. on brass I.D. tag, consult factory for ordering of this part.
- 4) See FM0160 Parts Price Sheet for listing of parts prices.

© Copyright 2006 Zoeller Co. All rights reserved.

# REPLACEMENT PARTS LIST FOR MODEL "XE4405".

See back page for illustration.

REF NO.	DESCRIPTION	QTY	NOTES	MODELS:			
				XE4405-A	XE4405-B	XE4405-C	XE4405-D
				1/94 thru 10/97	11/97 thru 6/98	7/98 thru 4/03	5/03 thru Current
1	COVER & CORD ASM.	1	3	006151	006151	011041	012464
2	BOLT, EYE	1		005926	005926	005926	N/A
3	COVER-MACH.	1	3	005865	005865	008860	008857
4	• GASKET,CASE/COVER	1		001011	001011	001011	001011
5	RELAY, 230V	1		217093	217093	217093	217093
6	• WIRE PKG (5) WIRES 1.5/2 HP	1		004751	004751	004751	004751
7	CAPACITOR & CLAMP ASM.	1		002381	010666	010666	010666
8	HOUSING, MTR. & STR.	1	1 & 2	006097	006097	006097	006097
9	BEARING, SLEEVE	1		001012	001012	001012	001012
10	• PLUG, TEST-WHITE	3		034090	034090	034090	034090
11	• SEAL, THRU WALL TERM.	3		003402	003402	003402	003402
12	ROTOR & BRG.	1	2	012192	012192	012192	012192
13	• BEARING, RADIAL	1		001013	001013	001013	001013
14	• SEAL, MTR HSG.	2		001014	001014	001014	001014
15	• OIL, DIELECTRIC-(44 OZ)	1		003168	003168	003168	003168
16	ADAPTER-MACH.	1		008862	008862	008862	008862
17	• WASHER, SEAL LOCATING & SNAP RING	1		011057	011057	011057	011057
18	• SEAL, SHAFT	2		002430	002430	002430	002430
19	ADAPTER-MACH. LOWER	1		008833	008833	008833	008833
20	IMPELLER ASM.	1		007671	007671	007671	007671
21	• KEY, WOODRUFF #404	1		006841	006841	006841	006841
22	• WASHER, 7/16 STD FLAT SS	1		006847	006847	006847	006847
23	• NUT, 7/16-20 SS HEX	1		006846	006846	006846	006846
24	HOUSING, PUMP-MACH.	1		005711	005711	005711	011784
25	CORD TERM. & SEAL POWER	1	3	004376	004376	004376	004376
26	• SEAL, CORD-ASM. & STR. RLF.	1	3	004375	004375	004375	004375
27	CLAMP, STRAIN RELIEF/2EAR.563/ZINC PL STL	0		N/A	N/A	N/A	N/A
28	CLAMP, #6 AUTO-SS	0		N/A	N/A	N/A	N/A
29	CORD, TERM. & SEAL CONTROL	1		004377	004377	011042	011042
30	• SEAL, CORD-ASM & STR. RLF. CONTROL CORD	1		004378	004378	094032	094032
31	CLAMP, STR. RLF.	1		N/A	N/A	001770	001770
32	• SCREW, #6-32X.25 RHM SL TC STLGR.	4		001877	001877	001877	001877
33	SWITCH, FLT-TERM. & SEAL	0		N/A	N/A	N/A	N/A
34	SEAL, CORD-ASM. & STRAIN RELIEF	0		N/A	N/A	N/A	N/A
35	CONNECTOR, WIRENUT	0		N/A	N/A	N/A	N/A
36	• SCREW, .25-20X.75 HHM-SS	4		001916	001916	001916	001916
37	• SCREW, .25-20X1" HHM-SS	4		007790	007790	007790	007790
38	• SCREW, .313-18 X 1"HH CAP-SS	10		002608	002608	002608	002608
39	• WASHER, LOCK SS .312 ID	2		N/A	N/A	006402	006402
40	BRACKET, LIFTING	1		N/A	N/A	010589	010589
41	RESISTOR ASSEMBLY	0		N/A	N/A	N/A	N/A
42	SENSOR WIRES	0		N/A	N/A	N/A	N/A
43	SENSOR CORDAGE TERM. & SEAL	0		N/A	N/A	N/A	N/A
44	SEAL, CORD-ASM. STR. RLF.	0		N/A	N/A	N/A	N/A
45	• WASHER, FLAT SS	0		N/A	N/A	N/A	N/A
▣	REBUILD KIT	1		012198	012198	012483	012382

• Items included in Rebuild Kit.

▣ Not Shown in Illustration.

## NOTES:

- 1) Mtr. Hsg., Brg., Stator & Term (Item 8) are preassembled at the factory and must be replaced as a unit. Stator is permanently attached to the Motor Housing. Plug (Item 10); Seal, Thru Wall Term. (Item 11) and Bearing - Upper (Item 9) are replaceable.
- 2) When ordering Motor Housing, Bearing, Stator and Term. (Item 8); or Rotor and Bearing (Item 12), specify either GE or Emerson motor.
- 3) If an "X" follows Model No., or Date Mfg. on brass I.D. tag, consult factory for ordering of this part.
- 4) See FM0160 Parts Price Sheet for listing of parts prices.

# REPLACEMENT PARTS LIST FOR MODELS "F4405" & "G4405".

See back page for illustration.

REF NO.	DESCRIPTION	QTY	NOTES	MODELS:				
				F4405-A	F4405-B		G4405-A	G4405-B
				1/94 thru 6/98	7/98 thru Current		1/94 thru 6/98	7/98 thru Current
1	COVER & CORD ASM.	1	3	011332	012466		011332	012466
2	BOLT, EYE	1		005926	N/A		005926	N/A
3	COVER-MACH.	1	3	005863	001077		005863	001077
4	• GASKET,CASE/COVER	1		001011	001011		001011	001011
5	RELAY, 230V	0		N/A	N/A		N/A	N/A
6	• WIRE PKG (5) WIRES 1.5/2 HP	0		N/A	N/A		N/A	N/A
7	CAPACITOR & CLAMP ASM.	0		N/A	N/A		N/A	N/A
8	HOUSING, MTR. & STR.	1	1 & 2	008592	008592		006343	006343
9	BEARING, SLEEVE	1		001012	001012		001012	001012
10	• PLUG, TEST-WHITE	3		034090	034090		034090	034090
11	• SEAL, THRU WALL TERM.	3		003402	003402		003402	003402
12	ROTOR & BRG.	1	2	012195	012195		012195	012195
13	• BEARING, RADIAL	1		001013	001013		001013	001013
14	• SEAL, MTR HSG.	2		001014	001014		001014	001014
15	• OIL, DIELECTRIC-(44 OZ)	1		003168	003168		003168	003168
16	ADAPTER-MACH.	1		008862	008862		008862	008862
17	• WASHER, SEAL LOCATING & SNAP RING	1		011057	011057		011057	011057
18	• SEAL, SHAFT	2		002430	002430		002430	002430
19	ADAPTER-MACH. LOWER	1		008833	008833		008833	008833
20	IMPELLER ASM.	1		007671	007671		007671	007671
21	• KEY, WOODRUFF #404	1		006841	006841		006841	006841
22	• WASHER, 7/16 STD FLAT SS	1		006847	006847		006847	006847
23	• NUT, 7/16-20 SS HEX	1		006846	006846		006846	006846
24	HOUSING, PUMP-MACH.	1		005711	011784		005711	011784
25	CORD TERM. & SEAL POWER	1	3	005131	005131		005131	005131
26	• SEAL, CORD-ASM. & STR. RLF.	1	3	094032	094032		094032	094032
27	CLAMP, STRAIN RELIEF/2EAR.563/ZINC PL STL	0		N/A	N/A		N/A	N/A
28	CLAMP, #6 AUTO-SS	0		N/A	N/A		N/A	N/A
29	CORD, TERM. & SEAL CONTROL	0		N/A	N/A		N/A	N/A
30	• SEAL, CORD-ASM & STR. RLF. CONTROL CORD	0		N/A	N/A		N/A	N/A
31	CLAMP, STR. RLF.	0		N/A	N/A		N/A	N/A
32	• SCREW, #6-32X.25 RHM SL TC STLGR.	1		001877	001877		001877	001877
33	SWITCH, FLT-TERM. & SEAL	0		N/A	N/A		N/A	N/A
34	SEAL, CORD-ASM. & STRAIN RELIEF	0		N/A	N/A		N/A	N/A
35	CONNECTOR, WIRENUT	0		N/A	N/A		N/A	N/A
36	• SCREW, .25-20X.75 HHM-SS	4		001916	001916		001916	001916
37	• SCREW, .25-20X1" HHM-SS	4		007790	007790		007790	007790
38	• SCREW, .313-18 X 1"HH CAP-SS	10		002608	002608		002608	002608
39	• WASHER, LOCK SS .312 ID	2		N/A	006402		N/A	006402
40	BRACKET, LIFTING	1		N/A	016801		N/A	016801
41	RESISTOR ASSEMBLY	0		N/A	N/A		N/A	N/A
42	SENSOR WIRES	0		N/A	N/A		N/A	N/A
43	SENSOR CORDAGE TERM. & SEAL	0		N/A	N/A		N/A	N/A
44	SEAL, CORD-ASM. STR. RLF.	0		N/A	N/A		N/A	N/A
45	• WASHER, FLAT SS	2		N/A	008773		N/A	008773
▣	REBUILD KIT	1		012197	016805		012197	016805

- Items included in Rebuild Kit.
- ▣ Not Shown in Illustration.

## NOTES:

- 1) Mtr. Hsg., Brg., Stator & Term (Item 8) are preassembled at the factory and must be replaced as a unit. Stator is permanently attached to the Motor Housing. Plug (Item 10); Seal, Thru Wall Term. (Item 11) and Bearing - Upper (Item 9) are replaceable.
- 2) When ordering Motor Housing, Bearing, Stator and Term. (Item 8); or Rotor and Bearing (Item 12), specify either GE or Emerson motor.
- 3) If an "X" follows Model No., or Date Mfg. on brass I.D. tag, consult factory for ordering of this part.
- 4) See FM0160 Parts Price Sheet for listing of parts prices.

© Copyright 2006 Zoeller Co. All rights reserved.

# REPLACEMENT PARTS LIST FOR MODELS "J4405" & "BA4405".

See back page for illustration.

REF NO.	DESCRIPTION	QTY	NOTES	MODELS:				BA4405-A	BA4405-B
				J4405-A	J4405-B	J4405-C		8/96 thru 6/98	7/98 thru Current
1	COVER & CORD ASM.	1	3	012190	012465	014161		011332	012466
2	BOLT, EYE	1		005926	N/A	N/A		005926	N/A
3	COVER-MACH.	1	3	005864	004372	014150		005863	001077
4	• GASKET,CASE/COVER	1		001011	001011	001011		001011	001011
5	RELAY, 230V	0		N/A	N/A	N/A		N/A	N/A
6	• WIRE PKG (5) WIRES 1.5/2 HP	0		N/A	N/A	N/A		N/A	N/A
7	CAPACITOR & CLAMP ASM.	0		N/A	N/A	N/A		N/A	N/A
8	HOUSING, MTR. & STR.	1	1 & 2	012193	012193	012193		011333	011333
9	BEARING, SLEEVE	1		001012	001012	001012		001012	001012
10	• PLUG, TEST-WHITE	3		034090	034090	034090		034090	034090
11	• SEAL, THRU WALL TERM.	3		003402	003402	003402		003402	003402
12	ROTOR & BRG.	1	2	012195	012195	012195		012195	012195
13	• BEARING, RADIAL	1		001013	001013	001013		001013	001013
14	• SEAL, MTR HSG.	2		001014	001014	001014		001014	001014
15	• OIL, DIELECTRIC-(44 OZ)	1		003168	003168	003168		003168	003168
16	ADAPTER-MACH.	1		008862	008862	008862		008862	008862
17	• WASHER, SEAL LOCATING & SNAP RING	1		011057	011057	011057		011057	011057
18	• SEAL, SHAFT	2		002430	002430	002430		002430	002430
19	ADAPTER-MACH. LOWER	1		008833	008833	008833		008833	008833
20	IMPELLER ASM.	1		007671	007671	007671		007671	007671
21	• KEY, WOODRUFF #404	1		006841	006841	006841		006841	006841
22	• WASHER, 7/16 STD FLAT SS	1		006847	006847	006847		006847	006847
23	• NUT, 7/16-20 SS HEX	1		006846	006846	006846		006846	006846
24	HOUSING, PUMP-MACH.	1		005711	011784	011784		005711	011784
25	CORD TERM. & SEAL POWER	1	3	012189	012189	014177		005131	005131
26	• SEAL, CORD-ASM. & STR. RLF.	1	3	004375	004375	015634		094032	094032
27	CLAMP, STRAIN RELIEF/2EAR.563/ZINC PL STL	1		N/A	N/A	013764		N/A	N/A
28	CLAMP, #6 AUTO-SS	0		N/A	N/A	N/A		N/A	N/A
29	CORD, TERM. & SEAL CONTROL	0		N/A	N/A	N/A		N/A	N/A
30	• SEAL, CORD-ASM & STR. RLF. CONTROL CORD	0		N/A	N/A	N/A		N/A	N/A
31	CLAMP, STR. RLF.	0		N/A	N/A	N/A		N/A	N/A
32	• SCREW, #6-32X.25 RHM SL TC STLGR.	1		001877	001877	001877		001877	001877
33	SWITCH, FLT-TERM. & SEAL	0		N/A	N/A	N/A		N/A	N/A
34	SEAL, CORD-ASM. & STRAIN RELIEF	0		N/A	N/A	N/A		N/A	N/A
35	CONNECTOR, WIRENUT	0		N/A	N/A	N/A		N/A	N/A
36	• SCREW, .25-20X.75 HHM-SS	4		001916	001916	001916		001916	001916
37	• SCREW, .25-20X1" HHM-SS	4		007790	007790	007790		007790	007790
38	• SCREW, .313-18 X 1"HH CAP-SS	10		002608	002608	002608		002608	002608
39	• WASHER, LOCK SS .312 ID	2		N/A	006402	006402		N/A	006402
40	BRACKET, LIFTING	1		N/A	010589	016801		N/A	016801
41	RESISTOR ASSEMBLY	0		N/A	N/A	N/A		N/A	N/A
42	SENSOR WIRES	0		N/A	N/A	N/A		N/A	N/A
43	SENSOR CORDAGE TERM. & SEAL	0		N/A	N/A	N/A		N/A	N/A
44	SEAL, CORD-ASM. STR. RLF.	0		N/A	N/A	N/A		N/A	N/A
45	• WASHER, FLAT SS	2		N/A	N/A	008773		N/A	008773
▣	REBUILD KIT	1		012197	012381	016805		012197	016805

• Items included in Rebuild Kit.

▣ Not Shown in Illustration.

## NOTES:

- 1) Mtr. Hsg., Brg., Stator & Term (Item 8) are preassembled at the factory and must be replaced as a unit. Stator is permanently attached to the Motor Housing. Plug (Item 10); Seal, Thru Wall Term. (Item 11) and Bearing - Upper (Item 9) are replaceable.
- 2) When ordering Motor Housing, Bearing, Stator and Term. (Item 8); or Rotor and Bearing (Item 12), specify either GE or Emerson motor.
- 3) If an "X" follows Model No., or Date Mfg. on brass I.D. tag, consult factory for ordering of this part.
- 4) See FM0160 Parts Price Sheet for listing of parts prices.

© Copyright 2006 Zoeller Co. All rights reserved.

# REPLACEMENT PARTS ILLUSTRATION FOR 4405 - ALL MODELS.

APPLICABLE CORD,  
SEAL, & GROUND SCREW

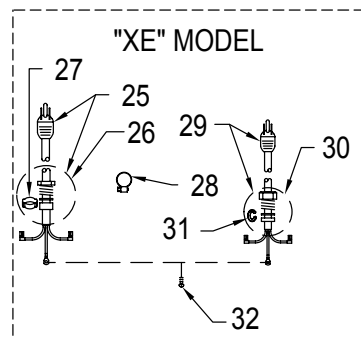
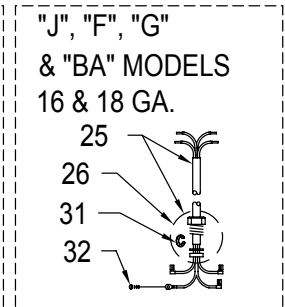
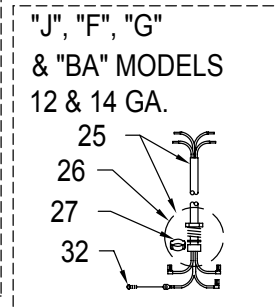
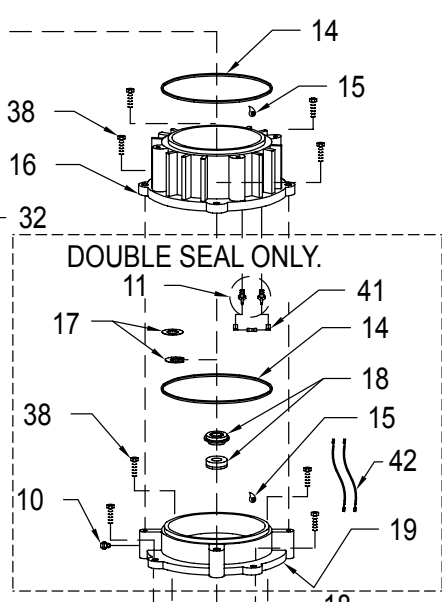
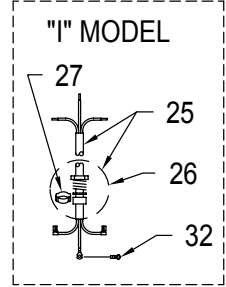
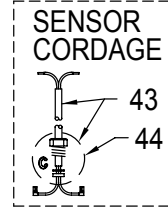
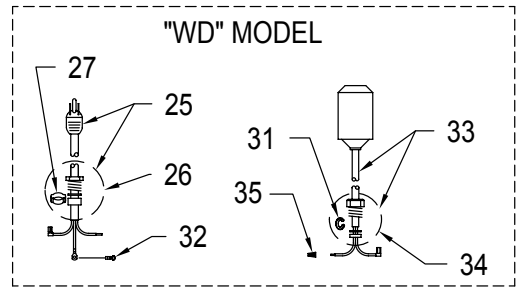
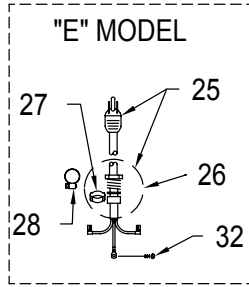
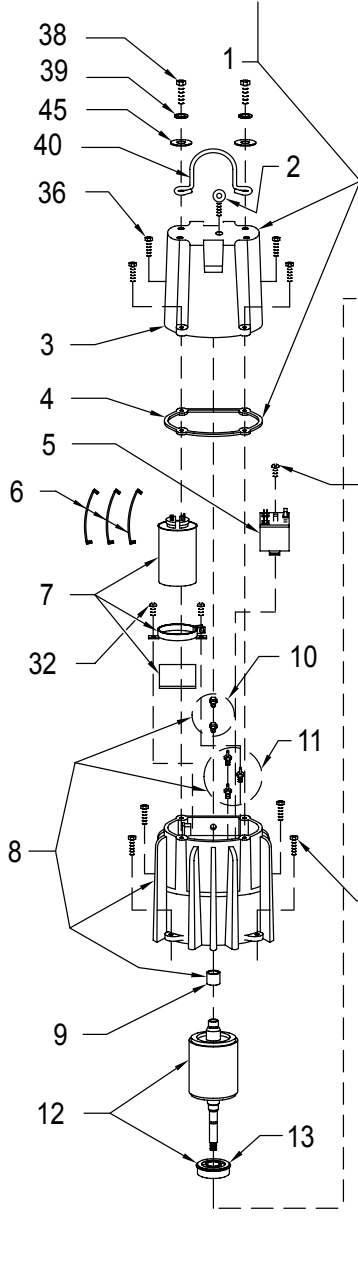

SK1814



www.zoeller.com

**ZOELLER**  
PUMP CO.

MAIL TO: P.O. BOX 16347  
Louisville, KY 40256-0347  
SHIP TO: 3649 Cane Run Road  
Louisville, KY 40211-1961  
(502) 778-2731 • 1 (800) 928-PUMP  
FAX (502) 774-3624

Manufacturers of...  
*"QUALITY PUMPS SINCE 1939"*