

NOTICE TO INSTALLER: Instructions must remain with installation.

SECTION: 6.10.041

"QUALITY PUMPS SINCE 1939"

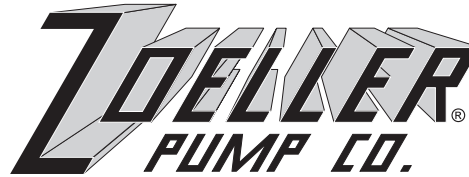

FM2298
0205
Supersedes
New

Product information presented here reflects conditions at time of publication. Consult factory regarding discrepancies or inconsistencies.

MAIL TO: P.O. BOX 16347 • Louisville, KY 40256-0347
SHIP TO: 3649 Cane Run Road • Louisville, KY 40211-1961
(502) 778-2731 • 1 (800) 928-PUMP • FAX (502) 774-3624

visit our web site:
www.zoeller.com



OWNER'S MANUAL



ZOELLER HAZARDOUS ENVIRONMENT PUMPS (For Class 1, Division 1, Groups C & D Applications) Explosion Proof Motors

EFFLUENT	SEWAGE
X161, X163, X165 X188, X189	X282, X284 X292, X293, X294, X295 X404, X405

Table of Contents	
Safety Instructions	1
Limited Warranty	2
Preinstallation Checklist.....	2
Electrical Data.....	3
General Information	4-5
Pump Wiring Instructions.....	6
Operation.....	7
General Maintenance	8
Service Checklist.....	8

Safety Instructions	
<p>TO AVOID SERIOUS OR FATAL PERSONAL INJURY OR MAJOR PROPERTY DAMAGE, READ AND FOLLOW ALL SAFETY INSTRUCTIONS IN THIS MANUAL AND ON THE PUMP.</p> <p>THIS MANUAL IS INTENDED TO ASSIST IN THE INSTALLATION AND OPERATION OF THIS UNIT AND MUST BE KEPT WITH THE PUMP.</p>	
	<p>This is a SAFETY ALERT SYMBOL. When you see this symbol on the pump or in the manual, look for one of the following signal words and be alert to the potential for personal injury or property damage.</p>
	<p>▲ DANGER Warns of hazards that WILL cause serious personal injury, death or major property damage.</p>
	<p>▲ WARNING Warns of hazards that CAN cause serious personal injury, death or major property damage.</p>
	<p>▲ CAUTION Warns of hazards that CAN cause personal injury or property damage.</p>
	<p>▲ NOTICE INDICATES SPECIAL INSTRUCTIONS WHICH ARE VERY IMPORTANT AND MUST BE FOLLOWED.</p>
<p>THOROUGHLY REVIEW ALL INSTRUCTIONS AND WARNINGS PRIOR TO PERFORMING ANY WORK ON THIS PUMP.</p> <p>MAINTAIN ALL SAFETY DECALS.</p>	

Owner's Information	
Model Number: _____	Date Code: _____
<input type="checkbox"/> Simplex	<input type="checkbox"/> Duplex
Job Name: _____	
Distributor: _____	
Date of Purchase: _____	Zoeller S/O No.: _____
Contractor: _____	
Date of Installation: _____	
System Readings During Start-up: Voltage _____ Amps _____	

REFER TO WARRANTY ON PAGE 2.

Limited Warranty

Manufacturer warrants, to the purchaser and subsequent owner during the warranty period, every new product to be free from defects in material and workmanship under normal use and service, when properly used and maintained, for a period of one year from date of purchase by the end user, or 18 months from date of original manufacture of the product, whichever comes first. Parts that fail within the warranty period, one year from date of purchase by the end user, or 18 months from the date of original manufacture of the product, whichever comes first, that inspections determine to be defective in material or workmanship, will be repaired, replaced or remanufactured at Manufacturer's option, provided however, that by so doing we will not be obligated to replace an entire assembly, the entire mechanism or the complete unit. No allowance will be made for shipping charges, damages, labor or other charges that may occur due to product failure, repair or replacement.

This warranty does not apply to and there shall be no warranty for any material or product that has been disassembled without prior approval of Manufacturer, subjected to misuse, misapplication, neglect, alteration, accident or act of God; that has not been installed, operated or maintained in accordance with Manufacturer's installation instructions; that has been exposed to outside substances including but not limited to the following: sand, gravel, cement, mud, tar, hydrocarbons, hydrocarbon derivatives (oil, gasoline, solvents, etc.), or other abrasive or corrosive substances, wash towels or feminine sanitary products,

etc. in all pumping applications. The warranty set out in the paragraph above is in lieu of all other warranties expressed or implied; and we do not authorize any representative or other person to assume for us any other liability in connection with our products.

Contact Manufacturer at, 3649 Cane Run Road, Louisville, Kentucky 40211, Attention: Customer Service Department to obtain any needed repair or replacement of part(s) or additional information pertaining to our warranty.

MANUFACTURER EXPRESSLY DISCLAIMS LIABILITY FOR SPECIAL, CONSEQUENTIAL OR INCIDENTAL DAMAGES OR BREACH OF EXPRESSED OR IMPLIED WARRANTY; AND ANY IMPLIED WARRANTY OF FITNESS FOR A PARTICULAR PURPOSE AND OF MERCHANTABILITY SHALL BE LIMITED TO THE DURATION OF THE EXPRESSED WARRANTY.

Some states do not allow limitations on the duration of an implied warranty, so the above limitation may not apply to you. Some states do not allow the exclusion or limitation of incidental or consequential damages, so the above limitation or exclusion may not apply to you.

This warranty gives you specific legal rights and you may also have other rights which vary from state to state.

Preinstallation Information

1. **Inspect your pump.** Occasionally, products are damaged during shipment. If the unit is damaged, contact your distributor before using. **DO NOT** remove the test plugs in the cover nor the motor housing.
2. **Carefully read the literature** provided to familiarize yourself with specific details regarding installation and use. These materials should be retained for future reference.
3. **National Electrical Code (NEC) articles 500 through 503 explain in detail the requirements for the installation and wiring of electrical equipment in hazardous locations.**



▲ WARNING

SEE BELOW FOR LIST OF WARNINGS



▲ CAUTION

SEE BELOW FOR LIST OF CAUTIONS

1.  Not for use in acidic, methanol or ethyl acetate atmospheres.
2. Do not lift, carry, or hang pump by the electrical cables. Damage to the electrical cables can cause shock, burns or death.
3. **Make sure there is a properly grounded connection available.** All pumps are furnished with provisions for proper grounding to help protect you against the possibility of electrical shock.
4. Make certain that the control box is within the reach of the pump's power supply cord. **DO NOT USE AN EXTENSION CORD.** Extension cords that are too long or too light do not deliver sufficient voltage to the pump motor. But, more important, they could present a safety hazard if the insulation were to become damaged or the connection end were to fall into the sump.
5. **Make sure the pump electrical supply circuit is equipped with fuses and disconnect or circuit breakers of proper capacity.** A separate branch circuit is recommended, sized according to the "National Electrical Code" for the current shown on the pump nameplate.
6. Risk of electric shock - These pumps have not been investigated for use in swimming pool areas.
7. According to the state of California (Prop 65), this product contains chemicals known to the state of California to cause cancer and birth defects or other reproductive harm.
8. Electrical wiring and protection **must** be in accordance with the National Electrical Code per NEC articles 500 through 503 for installation in Class 1, Division 1, Group C & D environments, and any other applicable state and local electrical requirements.

1. Check to be sure your power source is capable of handling the voltage requirements of the motor, as indicated on the pump nameplate.
2. The float switches must be connected to an intrinsically safe circuit in the control panel. The installation of float switches is the responsibility of the installing party and care should be taken that the tethered float switch will not hang up on the pump apparatus or pit peculiarities and is secured so that the pump will shut off. It is recommended that rigid piping and fittings be used and the pit be 36" or larger in diameter.
3. **INFORMATION - VENT HOLE PURPOSE.** It is necessary that all submersible pumps capable of handling various sizes of solid waste be of the bottom intake design to reduce clogging and seal failures. If a check valve is incorporated in the installation, a vent hole (approx. 3/16") must be drilled in the discharge pipe below the check valve and pit cover to purge the unit of trapped air. Water stream will be visible from this hole during pump run periods. This vent hole should be checked periodically for clogging and cleaned as necessary. Trapped air is caused by agitation and/or a dry basin.
4. Water hammer creates momentary high pressure surges. These surges can cause severe damage to check valves and the piping system. Consideration for water hammer must be included in the piping system design. Reference ASPE Data Book, Chapter 2.33. Some systems may require external spring or lever weighted check valves or other engineered solutions.
5. Three phase pumps must be connected for proper rotation, which is counterclockwise looking into impeller inlet.
6. Care should be taken during the initial installation to be sure that adequate air supply is available whenever any person is in the basin. Always follow OSHA guidelines on confined space requirements.

Electrical Data

Model	HP	RPM	Voltage	Phase	Hertz	Amps				KVA Code	Winding Resistance Line-to-Line
						Full Load	In Air	Shut Off	Locked Rotor		
NX161	½	3450	115	1	60	15.5		7.7	31.2	J	.53/.46*
EX161	½	3450	230	1	60	7.5		3.6	15.6	J	4.74/3.88*
IX161	½	3450	200	1	60	8.8		6.3	16.7	H	3.59/2.94*
JX161	½	3450	200	3	60	6.4		3.1	23.0	R	6.25/5.12
FX161	½	3450	230	3	60	5.2		2.7	12.5	L	5.7/4.6
GX161	½	3450	460	3	60	2.9		1.4	12.4	T	22.8/18.5
NX163	½	3450	115	1	60	15.0		8.4	31.2	J	.53/.46*
EX163	½	3450	230	1	60	7.5		4.0	15.6	J	4.74/3.88*
IX163	½	3450	200	1	60	8.5		4.3	16.7	H	3.59/2.94*
JX163	½	3450	200	3	60	6.0		3.4	23.0	R	6.25/5.12
FX163	½	3450	230	3	60	4.8		3.0	12.5	L	5.7/4.6
GX163	½	3450	460	3	60	2.9		1.5	12.4	T	22.8/18.5
EX165	1	3450	230	1	60	10.2		5.5	19.0	D	3.06/2.51*
IX165	1	3450	200	1	60	12.6		6.1	26.9	F	2.11/1.72*
JX165	1	3450	200	3	60	7.5		4.1	30.0	M	3.74/3.06
FX165	1	3450	230	3	60	7.4		3.8	14.0	F	5.7/4.5
GX165	1	3450	460	3	60	3.7		2.1	14.0	M	22.6/18.2
BAX165	1	3450	575	3	60	3.0		1.7	14.4	R	38.8/34.5
EX188	1½	3450	230	1	60	14.0		7.4	38.0	G	1.29/1.05*
IX188	1½	3450	200	1	60	16.8		9.8	48.3	H	.86/.71*
JX188	1½	3450	200	3	60	10.3		4.7	42.0	L	2.62/2.14
FX188	1½	3450	230	3	60	8.9		4.1	35.0	L	3.5/2.8
GX188	1½	3450	460	3	60	4.6		2.0	18.0	L	13.9/11.3
BAX188	1½	3450	575	3	60	3.5		1.6	18.0	N	20.6/18.3
EX189	2	3450	230	1	60	17.1		9.4	38.0	D	1.29/1.05*
IX189	2	3450	200	1	60	20.5		11.5	48.3	E	.86/.71*
JX189	2	3450	200	3	60	13.2		5.9	42.0	J	2.62/2.14
FX189	2	3450	230	3	60	11.2		5.1	35.0	H	3.5/2.8
GX189	2	3450	460	3	60	6.0		2.8	18.0	J	13.9/11.3
BAX189	2	3450	575	3	60	5.8		2.1	18.0	K	20.6/18.3
NX282	½	1725	115	1	60	10.3		7.3	27.0	G	1.46/1.20*
EX282	½	1725	230	1	60	5.0		4.0	14.0	H	5.84/4.80*
IX282	½	1725	200	1	60	6.1		4.5	17.2	H	4.65/4.05*
JX282	½	1725	200	3	60	3.6		2.5	16.0	M	8.13/6.62
FX282	½	1725	230	3	60	3.0		2.3	11.5	L	9.6/7.9
GX282	½	1725	460	3	60	1.7		1.1	8.5	P	38.4/31.5
EX284	1	1725	230	1	60	8.9		6.7	24.0	F	2.62/2.14*
IX284	1	1725	200	1	60	9.3		6.4	22.0	D	2.01/1.82*
JX284	1	1725	200	3	60	5.5		4.0	21.4	J	2.99/2.70
FX284	1	1725	230	3	60	5.0		3.5	15.5	G	4.8/4.4
GX284	1	1725	460	3	60	2.6		1.9	9.0	J	19.2/17.4
NX292	½	3450	115	1	60	15.0		10.6	53.0	N	.53/.46*
EX293	1	3450	230	1	60	10.2		5.5	31.0	J	3.06/2.51*
IX293	1	3450	200	1	60	12.0		6.4	34.0	H	2.11/1.72*
JX293	1	3450	200	3	60	8.2		4.4	30.0	M	3.74/3.06
FX293	1	3450	230	3	60	7.6		4.1	27.0	M	5.7/4.5
GX293	1	3450	460	3	60	4.0		2.2	14.0	M	22.6/18.2
BAX293	1	3450	575	3	60	3.3		1.8	12.0	N	38.8/34.5
EX294	1½	3450	230	1	60	13.7		8.1	38.0	G	1.29/1.05*
IX294	1½	3450	200	1	60	17.8		10.1	48.3	H	.86/.71*
JX294	1½	3450	200	3	60	10.8		5.3	42.0	L	2.62/2.14
FX294	1½	3450	230	3	60	9.5		4.5	35.0	L	3.5/2.8
GX294	1½	3450	460	3	60	4.8		2.3	18.0	L	13.9/11.3
BAX294	1½	3450	575	3	60	3.8		1.8	18.0	N	20.6/18.3
EX295	2	3450	230	1	60	17.1		9.1	38.0	D	1.29/1.05*
IX295	2	3450	200	1	60	20.5		11.5	48.3	E	.86/.71*
JX295	2	3450	200	3	60	14.3		6.3	42.0	J	2.62/2.14
FX295	2	3450	230	3	60	12.2		5.3	35.0	H	3.5/2.8
GX295	2	3450	460	3	60	6.1		2.7	18.0	J	13.9/11.3
BAX295	2	3450	575	3	60	4.9		2.2	18.0	K	20.6/18.3
EX404	2	1725	230	1	60	12.9		9.9	44.0	F	1.80/1.60*
IX404	2	1725	200	1	60	14.4		11.5	49.5	E	1.42/1.28*
JX404	2	1725	200	3	60	13.8		13.1	46.0	J	1.6/1.3
FX404	2	1725	230	3	60	10.5		9.7	42.0	K	2.3/2.0
GX404	2	1725	460	3	60	5.2		4.8	21.0	K	9.1/8.0
BAX404	2	1725	575	3	60	4.1		3.8	17.9	K	14.6/12.7
EX405	3	1725	230	1	60	19.0		9.3	44.0	B	1.80/1.60
IX405	3	1725	200	1	60	20.2		8.8	49.5	B	1.42/1.28*
JX405	3	1725	200	3	60	14.8		12.5	46.0	F	1.6/1.3
FX405	3	1725	230	3	60	12.2		9.7	39.5	F	2.3/2.0
GX405	3	1725	460	3	60	6.1		4.8	21.0	F	9.1/8.0
BAX405	3	1725	575	3	60	4.8		3.8	17.9	G	14.6/12.7

* Line to line reading will only reflect the run winding resistance.
Start winding resistance can only be measured after removing the cover.

General Information

HAZARDOUS ENVIRONMENTAL PUMP DESCRIPTION

1. Pumps are constructed of class 30 cast iron with powder coated epoxy protection for long life when pumping sewage in submersible applications.
2. Pump motors are available in single and three phase design.
3. The Hazardous Environmental Pump is a dual seal design and has seal leak probes. Single phase units have an internal thermal overload. Three phase pumps have a thermal sensor.
4. Three phase pumps require overload protection in the control panel.

FIELD ASSEMBLED INSTALLATION

1. Contractor shall furnish all labor, material, equipment and incidentals required for installation of hazardous environmental pump.
2. Installation and piping instructions are included with the rail system and basin instructions. If pump is being retrofitted to an existing rail system, accessory parts may be required. Consult the factory and advise make and model of rail system being used.
3. All electrical connections including pump to control box and power supply to control panels must comply with the "National Electrical Code" and applicable local codes. Installation of electrical panels and connections should be made by a qualified licensed electrician.
4. When installing a pump with a check valve, or a rail system with a check valve, you must give the pump case time to fill to help prevent air lock when lowering the unit into the liquid. The 6404/6405 pump case has an air vent located behind the discharge. This air vent is across the pump housing mounting surface and must be cleaned before each reinstall. An air vent hole (3/16") must be drilled in discharge pipe below the check valve to help prevent air lock. This drilled hole must be cleaned before each reinstall. After the pump is installed, run the unit submerged to assure the pump case is filled (Water should come out of 3/16" diameter hole).

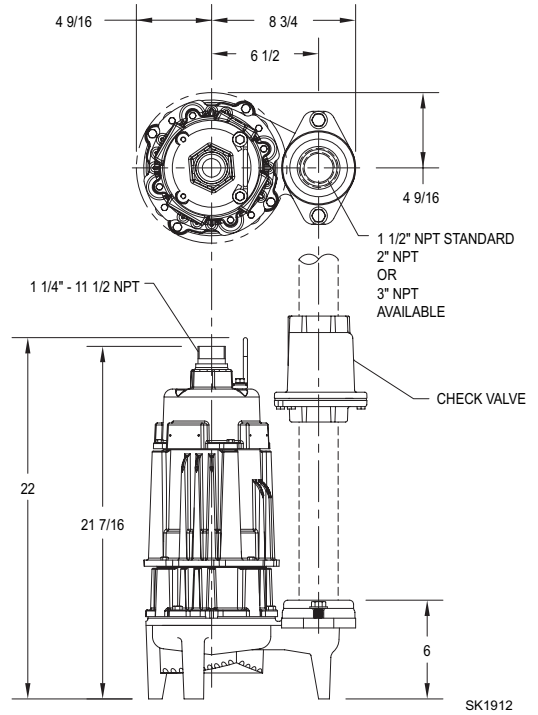
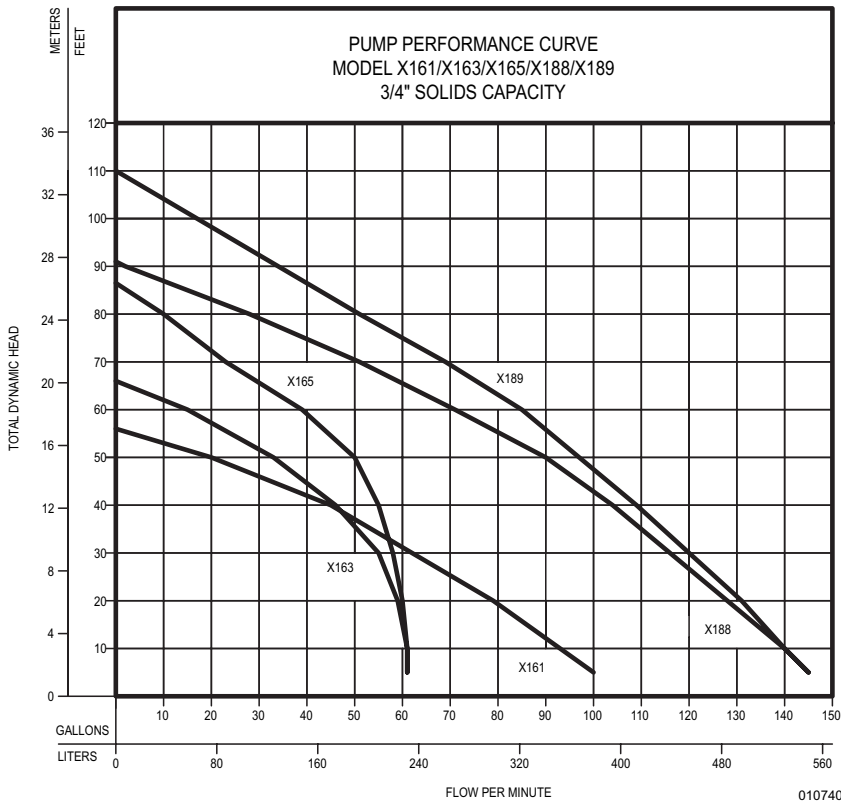

General Information (continued)

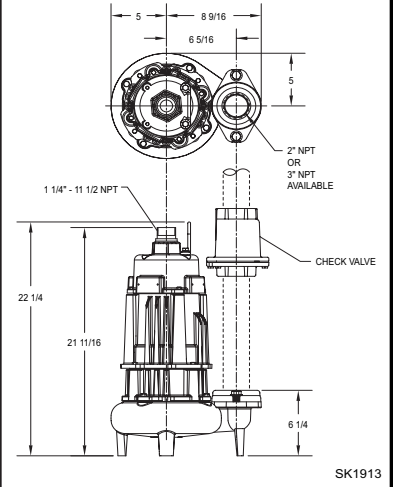
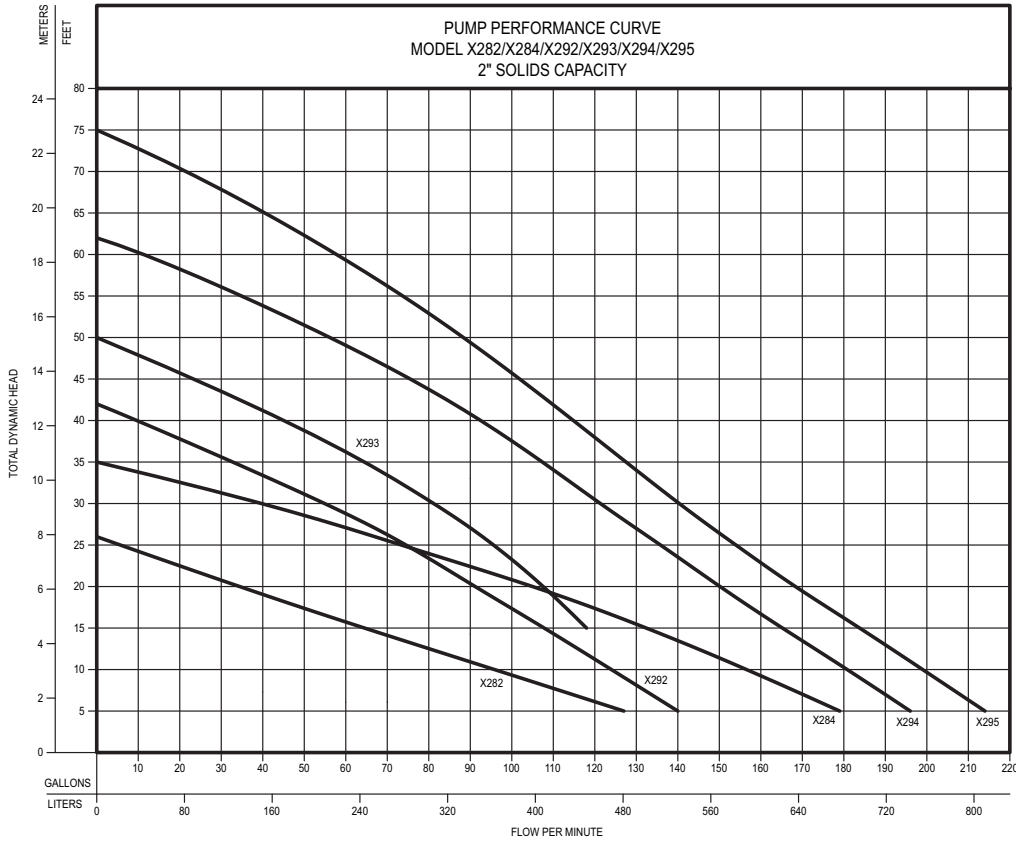

010739

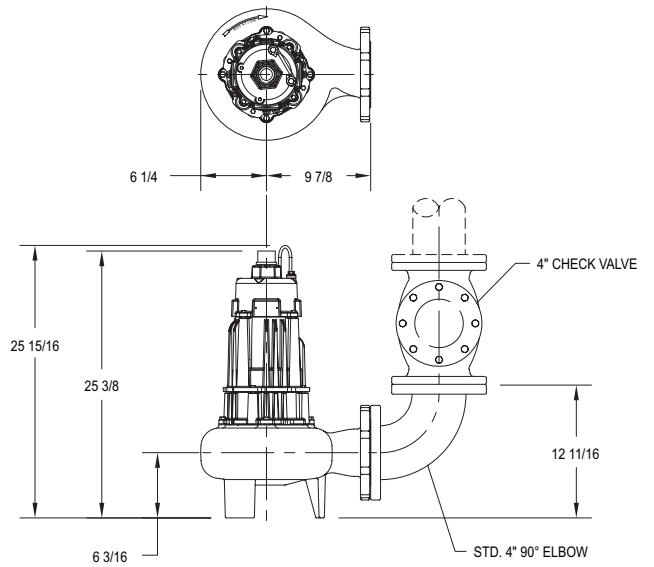
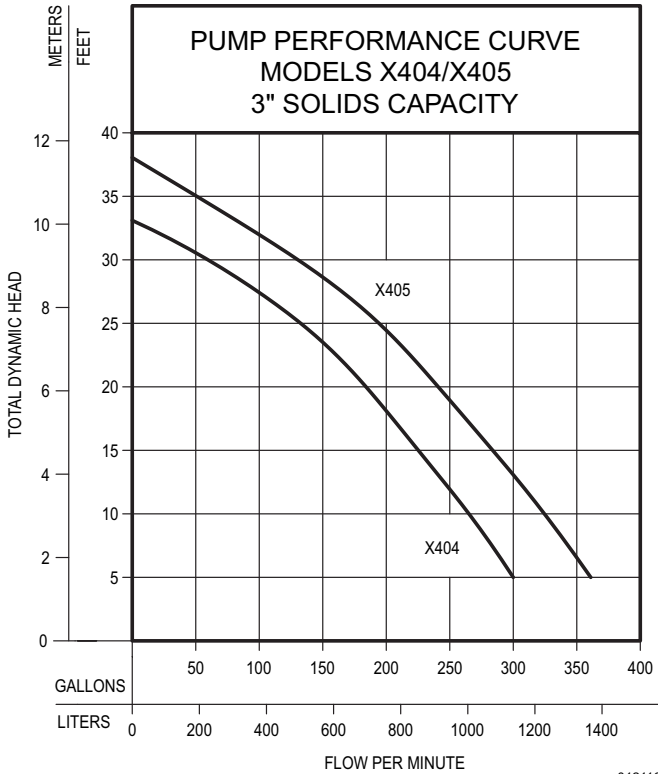

012116

Pump Wiring Instructions



▲ WARNING FOR YOUR PROTECTION, ALWAYS DISCONNECT THE PUMP FROM ITS POWER SOURCE BEFORE HANDLING.

▲ WARNING All electrical connections must be wired and grounded in accordance with the National Electrical Code and all applicable local codes and ordinances.



▲ WARNING **"Risk of electrical shock"** Do not remove the power supply cord or strain relief.

▲ WARNING Installation and checking of electrical circuits and hardware should be performed by a qualified licensed electrician.

EXPLOSION PROOF WIRING DIAGRAMS X160, X180, X280, X290, X400 SERIES



▲ WARNING Not for use in acidic, methanol or ethyl acetate atmospheres.

▲ WARNING *Moisture sensors must be terminated in an intrinsically safe circuit.

All installation of controls, protection devices and wiring should be done by a qualified licensed electrician. All electrical and safety codes should be followed including the most recent National Electric Code (NEC) and the Occupational Safety and Health Act (OSHA).

SINGLE PHASE

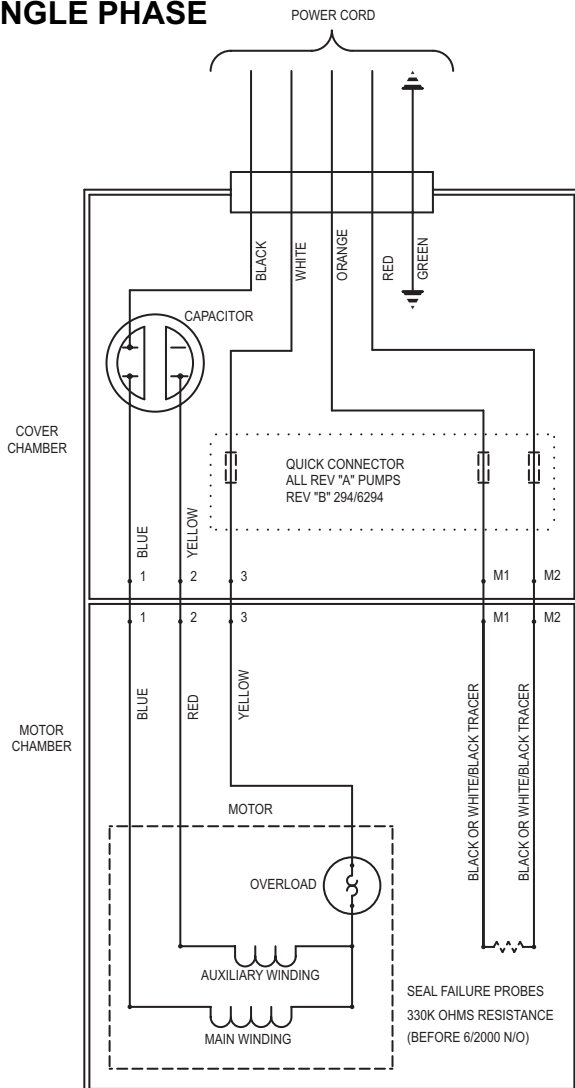

012941

THREE PHASE

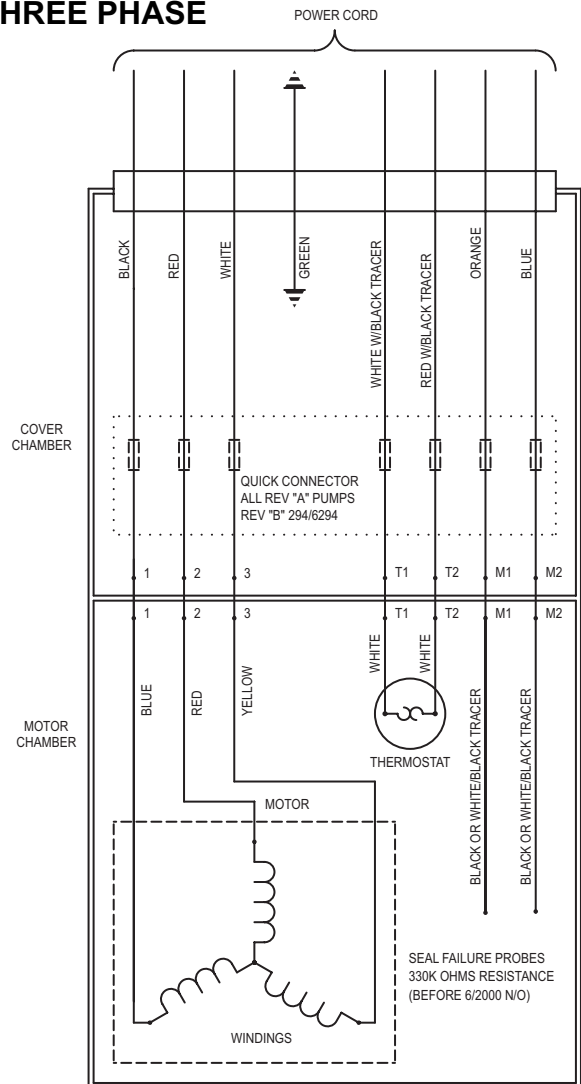

012943

Operation

GENERAL

Zoeller pumps are lubricated and tested at the factory prior to shipment and require minimum pre-start-up maintenance.

Maximum operating temperature of pump liquid must not exceed 104°F (40°C).

These units are not designed to handle liquids other than effluent: 160 and 180 or sanitary sewage: 280, 290 and 400. If pump is used to de-water areas with contaminated liquids with heavy or abrasive materials, the warranty will be voided.

NAMEPLATE DATA

The nameplate, located on the side of the pump, indicates specific information about the construction of the pump. The model number and date code information should be recorded on the front page in the "Owner's Information" section of this manual.

SHORT TERM STORAGE

When not in use, the pump should be stored and the following is advised:

- Store pump inside whenever possible or cover with some type of protective covering.
- Tape or seal in plastic bag the terminal ends of wire leads.
- Spray coat unpainted surfaces with rust inhibiting oil.
- The impeller should be rotated every six months in order to keep the seals lubricated and not develop a permanent set.

If panel is to be stored, the following is advised:

- Store the panel inside whenever possible and leave in the shipping box.
- All openings shall be sealed.
- Store in an upright position.
- Do not stack anything on top of panel.

START-UP PROCEDURE

Before placing the equipment into operation the following should be checked:

- Clean pit.
- Electrical boxes dry and securely installed.

- Floats positioned properly.
 - Discharge valves open.
 - 3/16" vent hole drilled in pipe between check valve and pump
- Once the above has been verified proceed with the following checks:

- Pump power cables and control floats properly installed and voltage verified.
- Conduit connections to panel are properly sealed.
- After installing the pump into the containment area, with adequate submergence, open the discharge valve fully. Start the unit using manual controls. If flow is appreciably less than rated performance, pump may be air locked. To expel trapped air, jog the unit several times, using the manual controls.
- Have a qualified electrician take voltage and current measurements with the pump running. Record these readings in the space provided in the "Owner's Information" section on page 1 of this manual for future reference.

ADJUSTMENT PROCEDURE

Pumps: No adjustments are required.

Floats: Refer to the system drawing or to the panel wiring schematic for the desired location of each float switch setting.

Valves: Discharge valves should be placed in the fully open position. Systems should not be operated for extended periods of time with the discharge valves partially closed due to damaging the valve.

SHUTDOWN PROCEDURES

If a system is shutdown for more than six months, the following is recommended:

Pumps: If pit is to remain dry, then the pump can remain in the pit. With the pump in the pit, it should be operated for five minutes once every three months. If the pit is to remain wet, the pump should be removed and stored as noted above.

Panels: The panel should have all openings sealed to prevent moisture and dust from entering the enclosure. Prior to restarting system, the panel should be inspected for presence of moisture and any loose connections.

Valves: Consult the valve/actuator supplier for information concerning these systems components.

General Maintenance

▲ NOTICE Repair and service must be performed by a firm approved by Zoeller Company. The firm must be certified to work on explosion proof motors if motor housing, adapter or cord cap is repaired. Contact Zoeller Technical Service Department regarding warranty issues.

▲ NOTICE If repair to the motor housing, adapter or cord cap is disassembled or repaired by a firm not certified to work on explosion proof motors, the explosion proof rating is void and the FM approval tag **MUST BE REMOVED FROM THE PUMP.**

SAFETY PROCEDURES

 **▲ WARNING** For your protection, always disconnect pump and panel from its power source before handling.

 **▲ WARNING** Never enter the basin until it has been properly vented and tested. Any person entering a basin should be wearing a harness with safety rope extending to the surface so that they can be pulled out in case of asphyxiation. Sewage water gives off methane and hydrogen sulfide gases, both of which can be highly poisonous.

Installation and checking of electrical circuits and hardware should be performed by a qualified electrician.

Pump is never to be lifted by power cord.

 **▲ WARNING** Unit must be cleaned and disinfected, inside the pumping chamber and all exterior surfaces, prior to servicing.

GENERAL SYSTEM INSPECTION

Before the system is placed into operation, it should be inspected by a qualified technician.

 **▲ WARNING** Wiring and grounding must be in accordance with the National Electrical Code and all applicable local codes and ordinances.

LUBRICATION PROCEDURES

No lubrication is required.

If pumps are to be stored for more than six months, refer to short term storage procedure in the Operation section.

PREVENTIVE MAINTENANCE

Preventive maintenance is recommended to ensure a long service life from the product. Provided is a suggested maintenance schedule.

Every month:

- Check for proper and unobstructed float operation.
- Listen for proper check valve operation.

Service Checklist

 **▲ WARNING** Electrical precautions. Before servicing the pump, always shut off the main power circuit. Make sure you are wearing insulated protective sole shoes and not standing in water. Under flooded conditions, contact your local electric company or a qualified licensed electrician for disconnecting electrical service to the pump prior to removal.

 **▲ WARNING** Pumps contain oil which becomes pressurized and hot under operating conditions. Allow 2½ hours after shut down before servicing pump.

Condition	Common Causes
A. Pump will not start or run.	Blown panel or circuit breaker fuse, low voltage, thermal overload open, defective capacitor circuit, impeller clogged, float switch held down or defective, incorrect wiring in control panel, water in cap assembly.
B. Motor overheats and trips on overload.	Incorrect voltage, impeller blocked, negative head (discharge lower than intake of pump). Defective "off" float. Pump runs continuously at low water level. Low oil level in motor shell.
C. Pump will not shut off.	Air lock, debris under float assembly, defective switch, incoming sewage exceeds capacity of pump.
D. Pump operates but delivers little or no water.	Intake clogged with grease or sludge, pump air locked (clear vent hole), low or incorrect voltage, clogged discharge line, operating near shut-off head.
E. Pump starts and stops too often.	Check valve stuck open or defective. Sump pit too small to handle incoming sewage. Level control out of adjustment. Thermal overload tripping.
F. Large red flashing light comes on at control box.	High water in pit. Check pump for clogging, or overload trip. See "A" and "D" above.
G. Grease and solids accumulate in pit around pump.	Break up solids and run pump with water running into the pit. Allow level to lower to the pump intake. Continue until solids are cleared from the pit. Do not drain kitchen grease down the sink.



www.zoeller.com

ZOELLER
PUMP CO.

MAIL TO: P.O. BOX 16347
Louisville, KY 40256-0347
SHIP TO: 3649 Cane Run Road
Louisville, KY 40211-1961
(502) 778-2731 • 1 (800) 928-PUMP
FAX (502) 774-3624

Manufacturers of . . .

"QUALITY PUMPS SINCE 1939"