

**Audio Patch Cords**

Suitable for General Audio Applications  
 2.8mm OD Black PVC Jacket  
 4.5mm OD Black PVC Guitar Cord Jacket  
 Fully Molded Construction  
 Nickel-plated connectors provide superior protection against corrosion  
 AWG26 Stranded Copper Center Conductor  
 Low-Loss 95% Spiral-Wound Copper Shield  
 99.99% Pure Oxygen-Free Copper Wire

- 255-155** 2' 3.5mm Mono Plug to Plug
- 255-160** 6' 3.5mm Mono Plug to Plug
- 255-165** 10' 3.5mm Mono Plug to Plug
- 255-170** 6' 3.5mm Mono Plug to RCA Plug
- 255-185** 10' Coiled 3.5mm Extension Cable  
3.5mm Stereo-Plug to Stereo-Jack
- 255-187** 25' Coiled 3.5mm Extension Cable  
3.5mm Stereo-Plug to Stereo-Jack
- 255-190** 25' Guitar Replacement Cable  
1/4" Mono-Plug to 1/4" Mono-Plug
- 255-195** 25' Coiled 1/4" St Extension Cable  
1/4" Stereo-Plug to 1/4" Stereo-Jack
- 255-255** 2' 3.5mm Stereo Plug to Plug
- 255-258** 6' 3.5mm Stereo Plug to Plug
- 255-262** 12' 3.5mm Stereo Plug to Plug
- 255-264** 25' 3.5mm Stereo Plug to Jack
- 255-265** 6' 3.5mm Stereo Plug to Jack
- 255-268** 12' 3.5mm Stereo Plug to Jack
- 255-269** 25' 3.5mm Stereo Plug to Jack

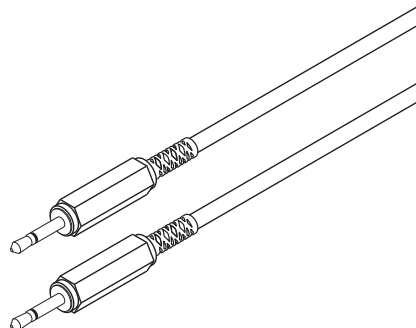

**255-155** 2' Mono  
**255-160** 6' Mono  
**255-165** 10' Mono

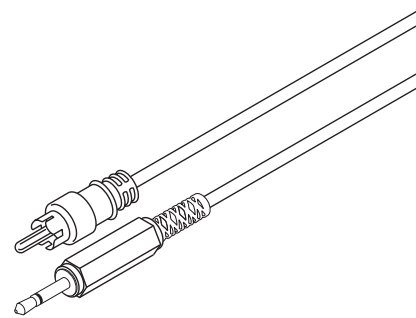

**255-170** 6' Mono

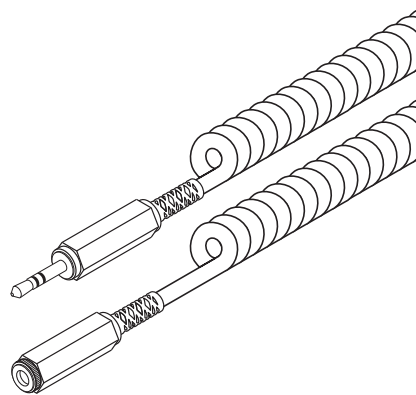

**255-185** 10' Stereo  
**255-187** 25' Stereo

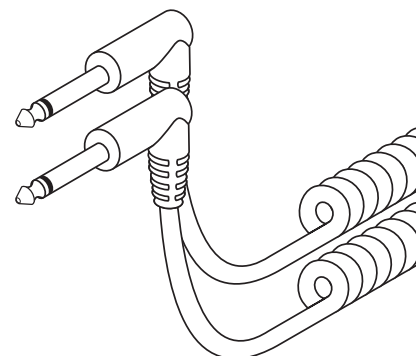

**255-190** 25' Mono

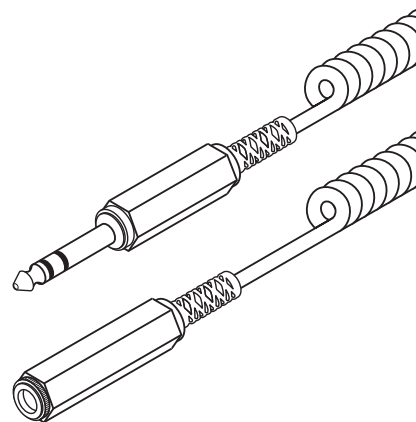

**255-195** 25' Stereo

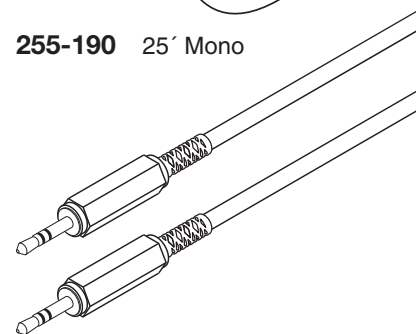

**255-255** 2' Stereo  
**255-258** 6' Stereo  
**255-262** 12' Stereo  
**255-264** 25' Stereo

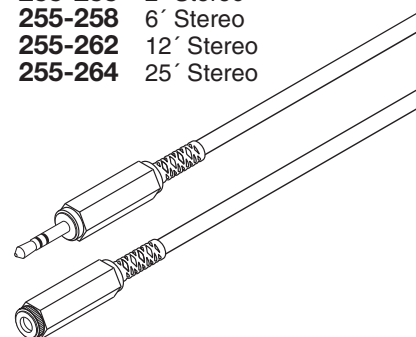

**255-265** 6' Stereo  
**255-268** 12' Stereo  
**255-269** 25' Stereo

**Microphone Cables**

Professional Quality Microphone Cables  
 Suitable for Microphones, Musical Instruments,  
 and Home Entertainment Systems  
 Reliable Transmission of Audio Frequencies  
 Minimize hum and cross-talk interference  
 6.0mm OD Black Flexible Rubber Jacket  
 Low-Loss Heavy Gauge Cable  
 Nickel-Plated Zinc-Alloy XLR Connectors  
 7x0.25mm AWG22 Center Conductors  
 Low-Loss 95% Spiral-Wound Copper Shield  
 99.99% Pure Oxygen-Free Copper Wire

- 255-290** 20' Microphone Cable  
1/4" Mono-Plug to 3-Pin XLR Jack
- 255-293** 60' Microphone Cable  
1/4" Mono-Plug to 3-Pin XLR Jack
- 255-295** 20' Microphone Extension Cable  
3-Pin XLR Plug to XLR Jack
- 255-298** 60' Microphone Extension Cable  
3-Pin XLR Plug to XLR Jack

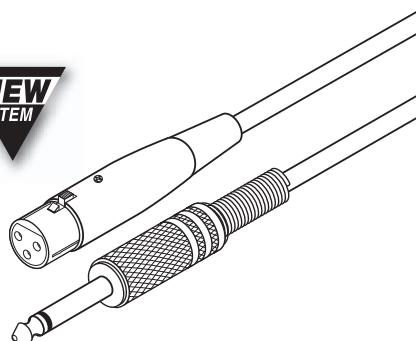

**255-290** 20'  
**255-293** 60'

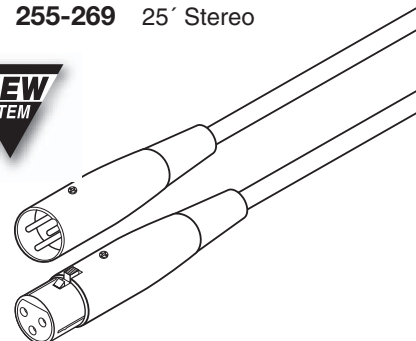

**255-295** 20'  
**255-298** 60'