

**Punch-Down Tools**

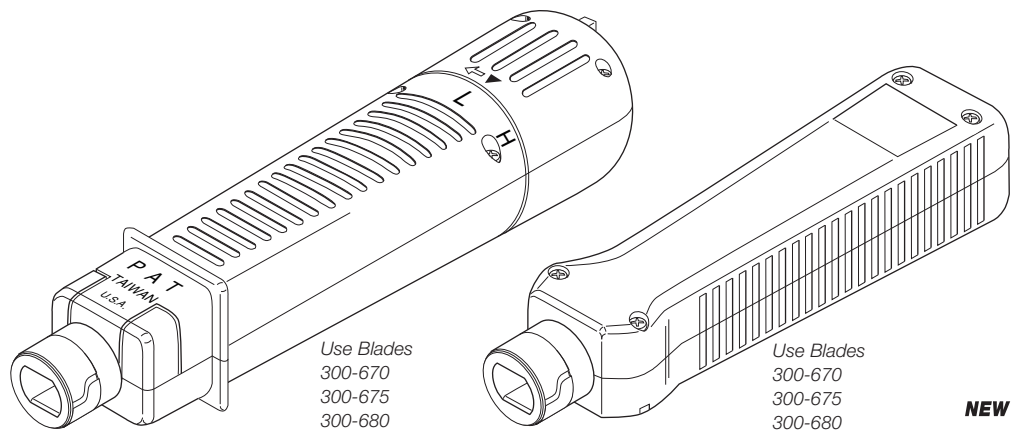

**300-650** Adjustable Impact *Use Blades 300-670 300-675 300-680*  
**300-655** Non-Adjustable Impact *Use Blades 300-670 300-675 300-680*  
**300-656** Non-Impact

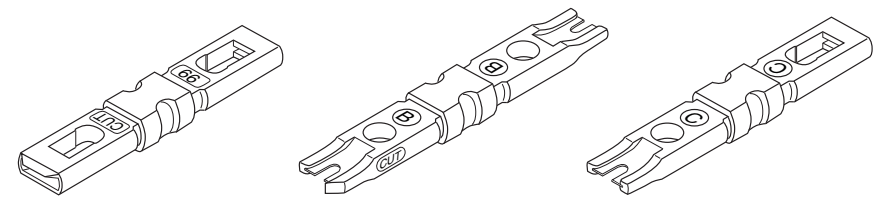

**300-670** Type 66    **300-675** Type 110/88    **300-680** Type 66 110/88

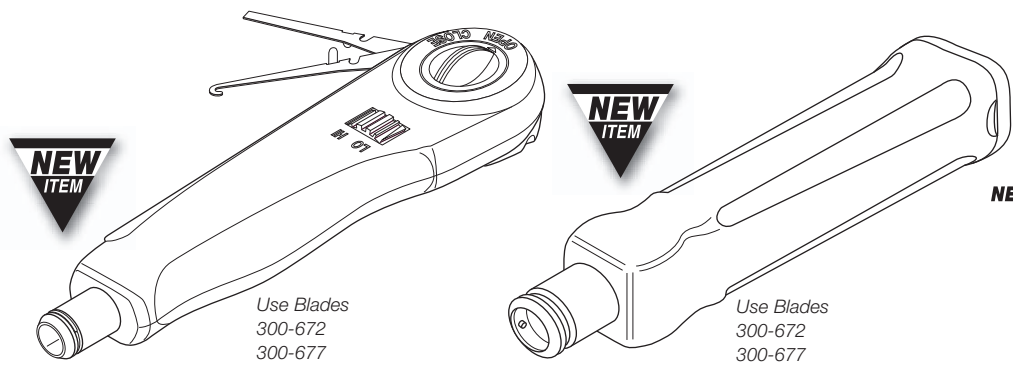

**300-653** Adjustable Impact *Use Blades 300-672 300-677*  
**300-658** Non-Impact *Use Blades 300-672 300-677*

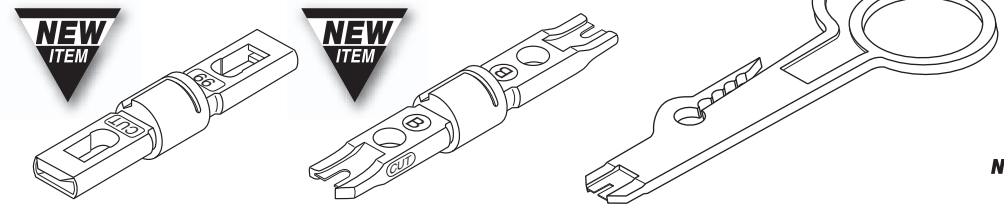

**300-672** Type 66    **300-677** Type 110/88    **300-657** Disposable

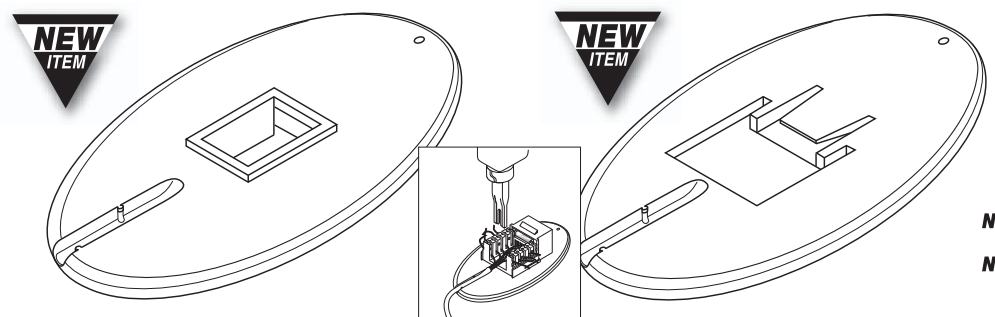

**310-180** 180° Jacks    **310-190** 90° Jacks

**300-650** Impact Punch-Down Tool  
 Spring-Loaded Adjustable Impact  
 Terminates and cuts conductors on 110/88 or 66 blocks  
 Spare Blade Storage Compartment  
 Clip-In Blades Supplied Separately

**NEW ► 300-653** Punch-Down Tool with Hook  
 Spring-Loaded Adjustable Impact  
 Terminates and cuts conductors on 110/88 or 66 blocks  
 Spare Blade Storage Compartment  
 Clip-In Blades Supplied Separately

**300-655** Non-Adjustable Punch-Down Tool  
 Terminates and cuts conductors on 110/88 or 66 blocks  
 Clip-In Blades Supplied Separately

**300-656** Non-Impact Punch-Down Tool  
 Terminates and cuts conductors on 110/88 or 66 blocks  
 Clip-In Blades Supplied Separately

**300-657** Disposable Punch-Down Tool  
 Inexpensive – Suitable for Small Jobs  
 Suitable for 5-6mm OD UTP/STP Cable  
 Terminates conductors on 110 blocks

**NEW ► 300-658** Non-Impact Punch-Down Tool  
 Terminates and cuts conductors on 110/88 or 66 blocks  
 Clip-In Blades Supplied Separately

**300-670** 66 Punch-Down Blade  
 Reversible Punch or Punch-and-Cut  
 Used with 300-650, 300-655, 300-656

**NEW ► 300-672** 66 Punch-Down Blade  
 Reversible Punch or Punch-and-Cut  
 Used with 300-653, 300-658

**300-675** 110/88 Punch-Down Blade  
 Reversible Punch or Punch-and-Cut  
 Used with 300-650, 300-655, 300-656

**NEW ► 300-677** 110/88 Punch-Down Blade  
 Reversible Punch or Punch-and-Cut  
 Used with 300-653, 300-658

**300-680** 66, 110/88 Punch-Down Blade  
 Punch Only Type  
 Used with 300-650, 300-655, 300-656

**Keystone Impact Chassis**

Keystone Jack Impact Chassis – Provides stable and sturdy surface for Keystone jack termination

**NEW ► 310-180** 180° Keystone Jack Impact Chassis

**NEW ► 310-190** 90° Keystone Jack Impact Chassis