

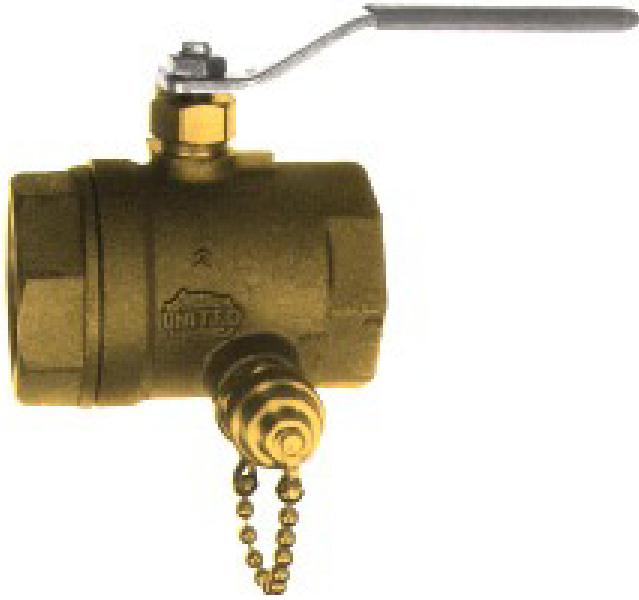

UNITED BRASS WORKS, INC.
 714 S. Main St., Randleman, NC 27317
 Tel: 800-334-3035 Fax: 800-498-4696 www.ubw.com



Model 80TSS Ball Valve

400 lbs. WOG
100% Pressure Tested
Blow-Out Proof Stem
3/8" Sampling Device

MATERIAL LIST

NO.	DESCRIPTION	MATERIAL
1	Lever	Plated Steel w/ Vinyl Grip
2	Stem	Brass
3	Jam Nut	Plated Steel
4	Packing Nut	Brass
5	Packing Sleeve	Brass
6	Packing	Graphite Non-Asb.
7	Bevel Washer	Steel
8	Tail Piece	Bronze
9	Body	Bronze
10	Ball	Chrome Plated Brass
11	Nest	PTFE
12	Sampler	86 3/8" (See Specs.)

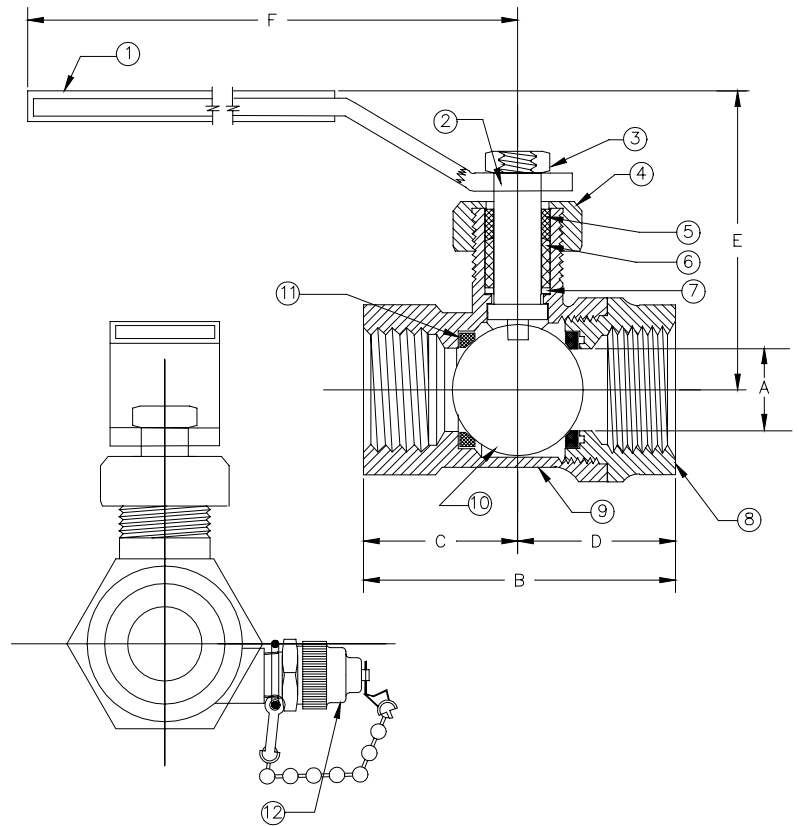

SIZE	A	B	C	D	E	F	SHIP WT. (lbs.)	QUAN. PER CTN.
2"	1.50	4.41	2.14	2.27	3.56	5.47	5.00	2