



UNITED BRASS WORKS, INC.
 714 S. Main St., Randleman, NC 27317
 Tel: 800-334-3035 Fax: 800-498-4696 www.ubw.com



Model 80MXF Ball Valve

Male x Female



200 lbs. WSP @ 406 ° Max
400 lbs. WOG
100% Pressure Tested
Blow-Out Proof Stem
1/4" - 1/2" Full Flow
3/4" - 2" Large Port Diameters

MATERIAL LIST

NO.	DESCRIPTION	MATERIAL
1	Lever	Plated Steel w/ vinyl grip
2	Stem	Brass
3	Jam Nut	Plated Steel
4	Packing Nut	Brass
5	Packing Sleeve	Brass
6	Packing	Graphite Non-Asb.
7	Bevel Washer	Steel
8	O-Ring	Nitrile Buna-N
9	Tail Piece (1/4" - 1/2") Tail Piece (3/4" - 2")	Brass Bronze
10	Body	Bronze
11	Ball	Chrome Plated Brass
12	Nest	PTFE

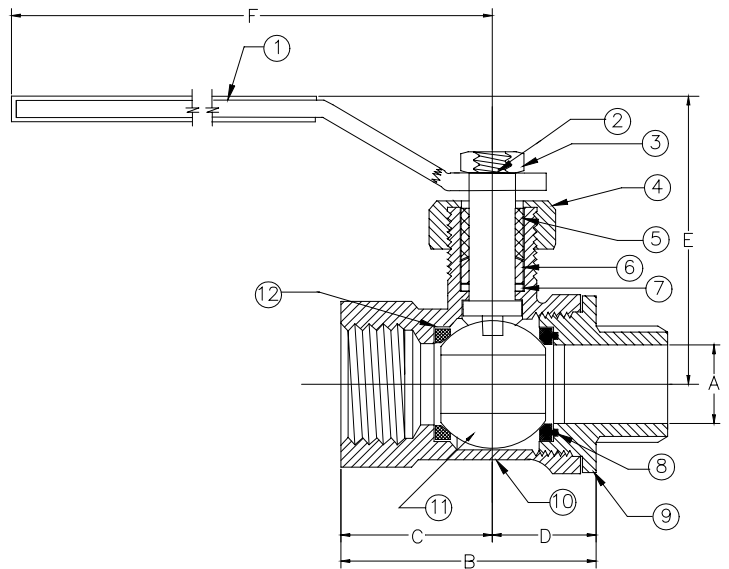

SIZE	A	B	C	D	E	F	SHIP WT. (lbs.)	QUAN. PER CTN.
1/4"	0.38	1.86	0.92	0.94	1.55	3.31	0.52	12
3/8"	0.38	1.86	0.92	0.94	1.55	3.31	0.52	12
1/2"	0.50	2.17	1.06	1.11	2.28	4.23	0.78	12
3/4"	0.63	2.52	1.20	1.3	2.35	4.23	0.98	12
1"	0.81	3.27	1.67	1.59	2.55	4.23	1.59	6
1 1/4"	1.00	3.48	1.72	1.77	3.19	5.47	2.47	4
1 1/2"	1.25	3.97	7.95	2.02	3.38	5.47	3.50	4
2"	1.50	4.41	2.14	2.27	3.56	5.47	5.00	2