

STELLAR XCHANGE



Economical, versatile and efficient, are just a few of the features offered by the Stellar Xchange Hooklift. Available in 9,000 and 13,000 pound capacities and fitting chassis with a cab to axle of 84" to 130", the Xchange is by far the simplest hooklift in the marketplace today.

Stellar Industries offers a well thought out convenient design. The Xchange system offers the lightest shipping weight in the industry, thus allowing for the greatest possible payload. With no grease zerks to



grease, Stellar Industries uses permanently lubricated bushings and stainless steel pins throughout the hooklift, as well as no wear pads that will wear out for replacement. In addition, all controls are mounted in the truck cab for safety and ease of operation.

At Stellar Industries, we work hard to give you an Exchange System that offers versatility while cutting cost and maintenance. At Stellar Industries, we are committed to giving you the competitive edge.



*Designed & Manufactured
in the USA*

STELLAR
INDUSTRIES INC.

9,000 / 13,000 Pound Capacity

STELLAR XCHANGE

9,000 / 13,000 - Pound Capacity Single Pivot Hooklift Loaders

Item Description	84-12-9	120-15-9	84-12-13	120-15-13	120-16-13
Lifting / Dumping Capacity (pounds)	9,000	9,000	13,000	13,000	13,000
A Dump Angle	50°	50°	50°	50°	48°
B Lowest Hook Height	26"	26"	26"	26"	26"
C Effective Length	116"	141"	116"	141"	151"
D Truck Frame Height	36"	36"	36"	36"	36"
E Loader Height	41.5"	41.5"	41.5"	41.5"	41.5"
F Loader Length	123"	148"	123"	148"	158"
G Loader Center of Gravity	49"	61"	49"	61"	66"
H Chassis Cab to Axle	84" to 96"	108" to 120"	84" to 96"	108" to 120"	120" to 130"
I Max. Height When Loading	117"	135"	117"	135"	135"
J Max. Height When Dumping	132"	146"	132"	146"	152"
Shipping Weight (pounds)	1,300	1,500	1,400	1,600	1,800
Recommended Body Lengths	10'-13'	12'-16'	10' to 13'	12' to 16'	14' to 17'
Hook Height (bottom of hook bar)	35.63"	35.63"	35.63"	35.63"	35.63"
Shipping Dimensions (LxHxW)	123"x51"x51"	148"x51"x51"	123"x51"x51"	148"x51"x51"	158"x51"x51"
Min. Truck GVWR (pounds)	14,000	14,000	19,000	19,000	19,000

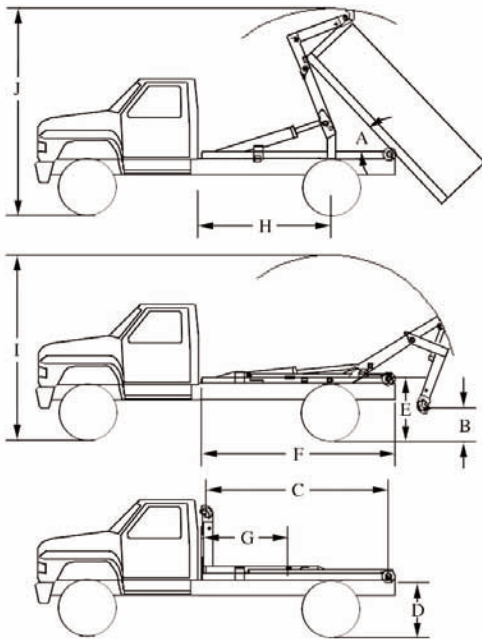

Features:

- Will accommodate bodies from 10-feet up to 17-feet long on a 36-inch high frame truck. Longer bodies will have reduced dumping capabilities.
- Transmission-mounted PTO and hydraulic pump required to power the hooklift loader.
- Standard in-cab manual controls which allow for precise metering of the manual stick-type hydraulic valve. Solenoid activated hydraulic control valve with electric remote control pendant is optional.
- Ten gallon frame-mounted oil reservoir.
- Operating pressure is 4,200 psi.
- Hydraulic flow required is 10 gallons per minute.
- Hydraulic locks to prevent cylinder collapse in case of hose failure.
- Hook safety latch to prevent body from becoming detached prematurely.
- Mechanical rear body tie-down latches.
- Permanently lubricated and greaseless bushings used throughout.



280 West Third Street
P.O. Box 169
Garner, IA 50438
Telephone: 800-321-3741
Fax: 641-923-2812
Internet: www.hooklift.com
email: sales@stellar-industries.com

STELLAR
INDUSTRIES INC.

Subject to change without notification.