

## Vision Series

■ The PA151 is an extremely versatile, wide-dispersion, two-way loudspeaker system offering substantial power and value for a variety of professional applications that include primary sound reinforcement and supplementary fill for large speaker systems.

■ The low-frequency transducer is a 15" woofer with a sturdy 3" voice coil that can provide excellent low-frequency response along with high power handling. The high-frequency section combines a modified constant directivity horn having a 1" exit and coupled to a compression driver with a 1.75" diaphragm assembly.

■ The system includes a high-level crossover network that features markedly lower (than conventional) inductance values in series with the woofer. We call this innovation LICC (Low Impedance Compensated Crossover). The benefit is delay reduction, reduced phase shift and superior transient response. Dynamic high-frequency driver protection is accomplished with a fast-response filament resistor, chosen to complement the power curve of the driver. The PA151's crossover is easily bypassed for bi-amp or tri-amp (with the PA180SW) operation via an installer-accessible changeover block. Back panel indicators display the current system setting.

■ The Mackie Industrial PA151 is a part of the VISION family of loudspeaker products including full-range, cost-effective, two-way loudspeakers and complementary subwoofer cabinets. The two-way enclosures have a trapezoidal footprint for easy array configuration. All enclosures are constructed using 19mm void-free, birch plywood and finished with a scratch resistant black coating. Transducer components are protected from the environment by a heavy gauge metal grille. The VISION products are eminently suited for fixed installation, ready for suspension, via built-in M10 inserts with metal reinforcement and forged shoulder eyebolt hardware.

■ This Mackie Industrial product is covered by an exclusive, one-time, NO FAULT repair policy in addition to a five year limited warranty.

## Two-Way Speaker System



## Features

- 15" high-efficiency, 3" voice-coil LF transducer
- 90° x 70° modified constant-directivity horn with 1" compression driver
- Dual-function design: built-in passive crossover or external bi-amp
- Trapezoidal enclosure for array configurations
- HF driver dynamic protection
- 19mm birch plywood construction
- Twelve suspension points (M10) and standard suspension hardware
- Integrated hand-carry locations
- Exclusive Mackie Industrial — one-time, NO FAULT repair policy
- 5 Year Limited warranty

- Cluster Configurations
- Live Music Reinforcement
- High-Level AV Playback
- Large Speech Systems

# PA151 Two-Way Speaker System

## Specifications

### System

Freq. Range (-10dB):	50Hz–20kHz
Freq. Response (-3dB):	80Hz–18kHz
Horz. Coverage Angle (-6dB):	90° averaged 2kHz to 10kHz
Vert. Coverage Angle (-6dB):	70° averaged 2kHz to 10kHz
Directivity Factor; Q (DI):	9.5 (9.8) averaged 2kHz to 10kHz
System Sensitivity <sup>1</sup> :	97dB, 1W @ 1m
Rated Maximum SPL:	130dB, @ 1m
System Nominal Impedance:	8Ω
System Input Power Rating <sup>2</sup> :	300W RMS; 1200W Peak
Recommended Amplifier <sup>3</sup> :	450W
HF Protection:	Dynamic
Crossover:	1.7kHz, 12dB/octave

### Transducers

Low-Frequency:	15" (380mm) woofer with 3" (76mm) coil
Nominal Impedance:	8Ω
Input Power Rating:	250W AES; 1000W Peak
Sensitivity <sup>1</sup> :	99dB, 1W @ 1m
Recommended Amplifier <sup>3</sup> :	400W
High-Frequency:	1" (25mm) throat, 1.75" (44mm) coil diaphragm assembly
Nominal Impedance:	8Ω
Input Power Rating:	35W AES; 140W Peak
Sensitivity <sup>1</sup> :	107dB, 1W @ 1m
Recommended Amplifier <sup>3</sup> :	50W

### Physical

Enclosure:	Trapezoidal, 15° side angles, 19mm multilayered birch
Rigging Inserts:	12 points; accepts M10 threaded hardware, 3 eyebolts provided
Color:	Black, scratch resistant paint
Grille:	Custom perforated steel grille with open-cell poly fiber backing
Input Connectors:	Speakon® NL4
Dimensions (HxWxD):	27.44" x 17.90" x 16.93" (697mm x 455mm x 430mm)
Net Weight:	72.6lb. (33kg)

### Options

PA-A1	Forged shoulder M10 eyebolt hardware
-------	--------------------------------------

<sup>1</sup> Measured on axis in the far field with 1 watt (2.83V RMS, 8Ω) input and referenced to 1 meter distance using the inverse square law. Listed sound pressure represents an average from 300Hz to 3kHz.

<sup>2</sup> RMS using 20Hz to 20kHz, PN Spectrum, Peak for 2 hours with +6dB crest factor.

<sup>3</sup> Recommended Amplifier is a power capability value that should be taken as a guide.

# PA151 Two-Way Speaker System

## PA151 Vertical Polars

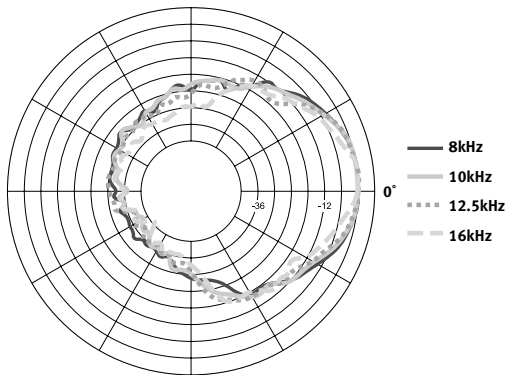
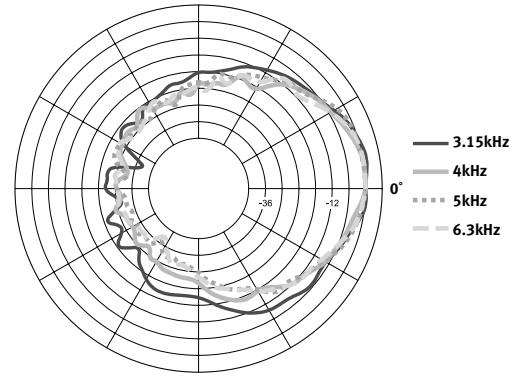
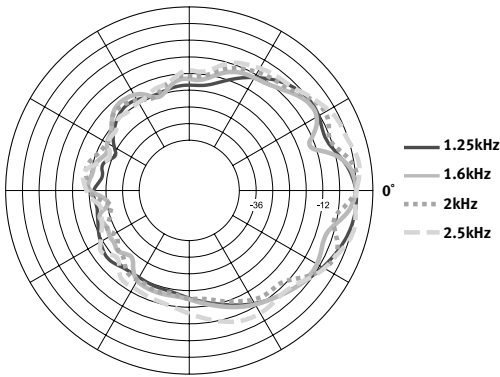
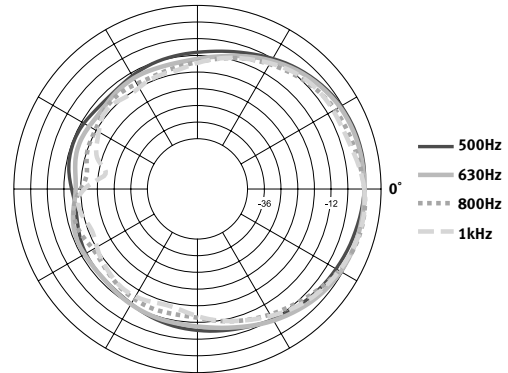
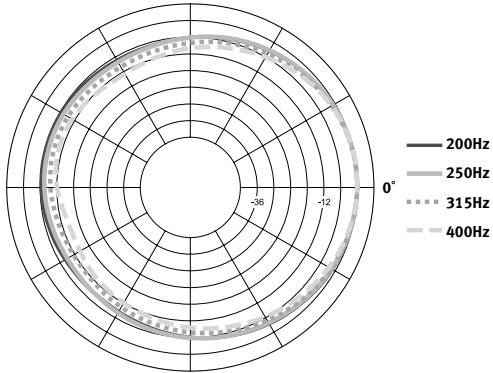

Vertical Off-Axis Frequency Response

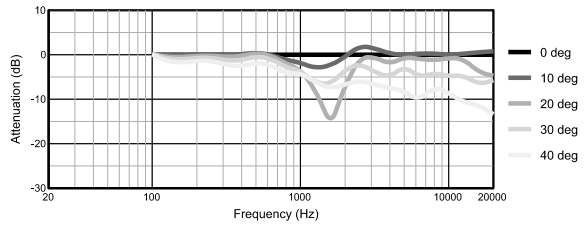

Vertical Off-Axis Frequency Response

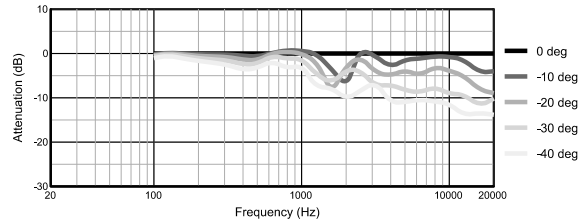

**PA151**  
Horizontal Polars

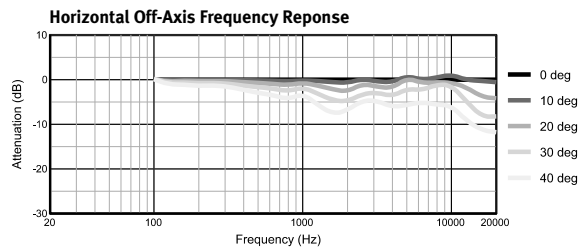
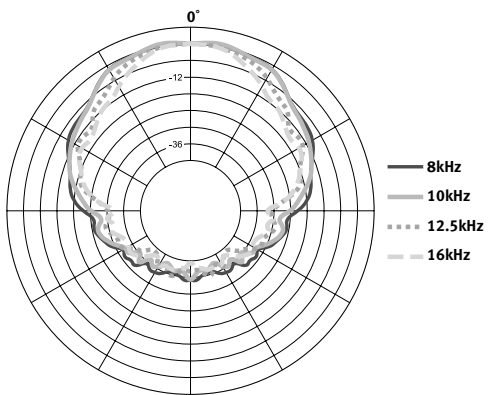
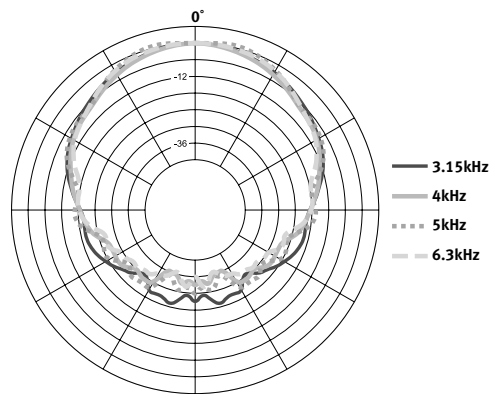
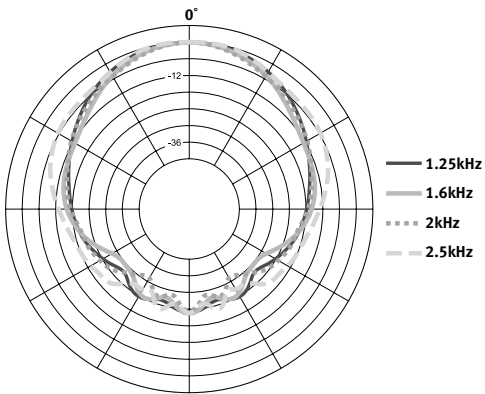
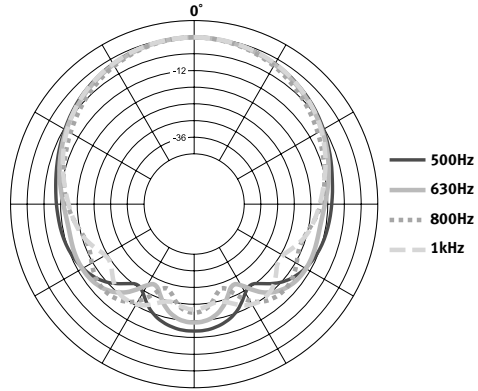
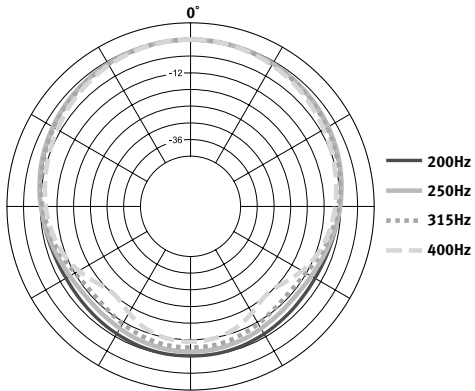

# PA151 Two-Way Speaker System

Frequency response is measured on-axis at a distance referenced back to 1m at 1-watt drive. Shown as a half space ( $2\pi$ ) environment.

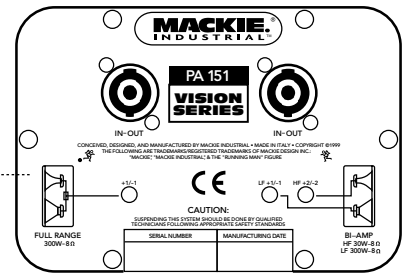
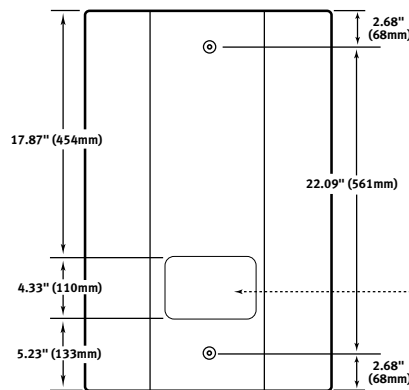
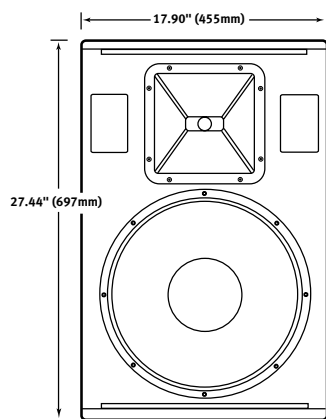
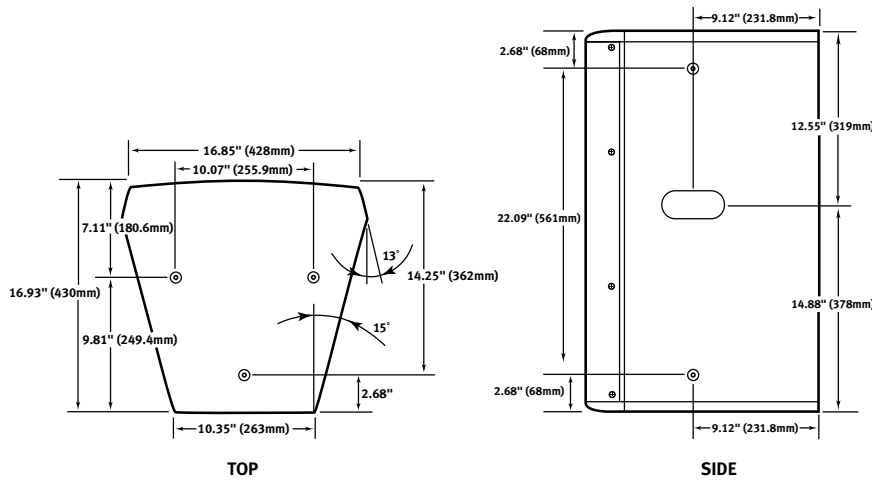
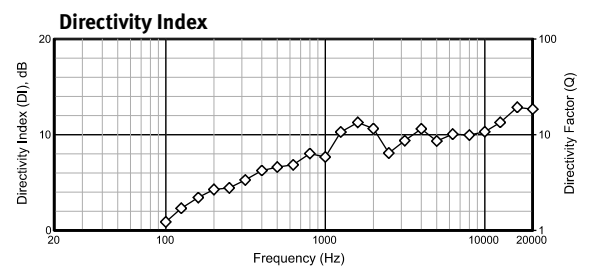
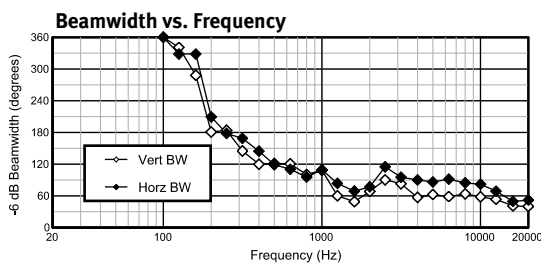
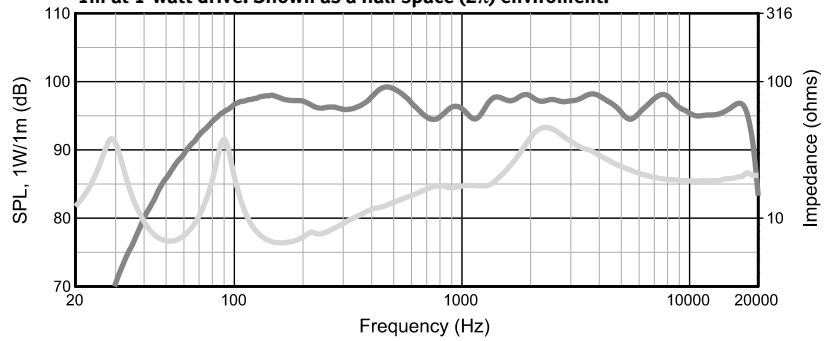

# PA151 Two-Way Speaker System

## Architects' and Engineers' Specifications

The two-way loudspeaker system shall be self-contained and consist of the following components: (1) a 15-inch, low-frequency driver; (2) a high-frequency section consisting of a constant-directivity horn and compression driver; (3) a two-way crossover network; (4) a vented enclosure.

The low-frequency transducer shall be a cone type loudspeaker having a cone diameter of at least 15 inches (380mm). It shall have a voice coil of at least 3 inches (76mm) in diameter. It shall present a nominal load impedance of 8Ω. Sensitivity shall be at least 99dB when measured at 1m with an input of 1 Watt and have a power rating of at least 250 Watts (AES), 1000 Watts peak.

The high-frequency section shall have a compression driver with a diaphragm of at least 1.75 inches (44mm) in diameter. It shall present a constant-impedance load of 8Ω. It shall be connected to a constant-directivity horn having a throat diameter of at least 1 inch (25mm) and a nominal coverage pattern of 90° horizontal by 70° vertical. Sensitivity shall be at least 107dB when measured at 1m with an input of 1 Watt and have a power rating of at least 35 Watts (AES), 140 Watts peak.

The system shall be crossed over by an internal, high-level, passive network having a response of 12dB/octave. The nominal crossover frequency shall be 1.7kHz. The low-pass section of the network shall have minimum inductance in series with the low-frequency driver. The high-pass section of the network shall be equalized to optimize the performance of the constant-directivity horn. A dynamic high-frequency protection circuit based on a low-value, low-mass filament resistor shall limit the current available to the compression driver. A connection option shall be provided to disconnect the crossover network, but not the high-frequency protection circuit, from the drivers to allow bi-amp operation. Connections to the loudspeaker shall be Speakon® NL4 connectors.

The enclosure shall be a vented design with an internal volume of at least 2.57 cu. ft. and a vent tuning of 50Hz. It shall be constructed using 0.75 inch (19mm), void-free birch plywood and finished with black, scratch-resistant paint. It shall be trapezoidal shaped with 15° angled sides. A full size, detachable, perforated steel grille, finished in black scratch-resistant paint shall be provided. At least 10 reinforced threaded metal sockets (M10) for attaching mounting

## (continued Architects' & Engineers' Specs)

hardware, three eye bolts and two hand-carry locations shall also be provided. The overall dimensions of the enclosure shall not exceed 27.44 x 17.9 x 16.93 inches (697mm x 455mm x 430mm).

The performance of the two-way loudspeaker system shall be as follows: long-term power handling, at least 300 Watts RMS; peak power handling, at least 1200 Watts; frequency response, 80Hz–18kHz at –3dB; maximum SPL, 130dB (anechoic–1m); sensitivity, 97dB SPL (1W/1m anechoic); –6dB coverage, measured average 2kHz–16kHz, 90° horizontal by 70° vertical. The two-way loudspeaker system shall be a model PA151 manufactured by Mackie Industrial.



[www.mackieindustrial.com](http://www.mackieindustrial.com)

16220 Wood-Red Rd. NE, Woodinville, WA 98072 USA  
888.337.7404, fax 425.487.4337, [industrial@mackie.com](mailto:industrial@mackie.com)

UK +44.1268.571.212, fax +44.1268.570.809, [info@rcf-uk.com](mailto:info@rcf-uk.com)  
ITALY +39.0522.354.111, fax +39.0522.926.208, [industrial@rcf.it](mailto:industrial@rcf.it)  
FRANCE +33.3.8546.9160, fax +33.3.8546.9161, [rcf.commercial@wanadoo.fr](mailto:rcf.commercial@wanadoo.fr)  
GERMANY +49.2572.96042.0, fax +49.2572.96042.10, [industrial@mackie.de](mailto:industrial@mackie.de)

Electronic files for this product available at:  
[www.mackieindustrial.com](http://www.mackieindustrial.com)

This Specification Sheet

PA151.PDF

Mackie Designs continually engages in research related to product improvement. New material, production methods, and design refinements are introduced into existing products without notice as a routine expression of that philosophy. For this reason, any current Mackie Industrial product may differ in some respect from its published description, but will always equal or exceed the original design specifications unless otherwise stated. ©1999-2001 Mackie Designs Inc. All rights Reserved. **MACKIE** and  are registered trademarks of Mackie Designs Inc. Mackie Industrial is a trademark of Mackie Designs Inc.

part no. 910-152-10 Rev.B