

Does not interfere with production

Toftejorg SaniMidget Retractor, A Retractable Rotary Spray Head

Application

The Toftejorg SaniMidget Retractor is a retractable version of the Toftejorg SaniMidget rotary spray head. The tank cleaning head is automatically retracted and isolated from contact with the tank or duct contents when cleaning is complete. Machine components that come in contact with cleaning media or product are designed to be self-draining and self-cleaning.

The device is for use in tanks, vessels, dryers; and ducts where internal components or geometry complicate the placement of permanently installed cleaning machines. It is suitable for storage tanks, reactors and mixing tanks between 0.1 and 10 m³ (27 to 2,700 US gallons). Application and optimal positioning assistance is available in CAD format.

Working Principle

The Toftejorg SaniMidget Retractor is available with two styles of retracting mechanisms: Pneumatic Driven, which uses air pressure to extend and retract the cleaning head, and Media Driven, which uses the pressure of the cleaning media to extend the cleaning head and an integrated spring to retract it. The cleaner head is driven by the media and starts rotating upon application of media flow, creating fans of fluid in a swirling pattern. The distribution pattern of the cleaner head generates a vibrating impact as well as cascading flow coverage of all internal surfaces of the tank.

Spray Pattern

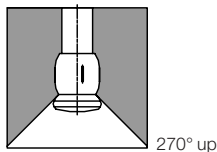

Standard Design

The Toftejorg SaniMidget Retractor is available in three stroke lengths: 100 mm, 150 mm and 250 mm, in either pneumatic- or media-driven versions. As standard documentation, it can be supplied with a "Declaration of Conformity" for material specifications.

Materials

Product area: 1.4404 (316L), PEEK
 Non-product area: 1.4301 (304), POM
 Sealing: EPDM
 Polymers FDA-approved 21 CFR § 177



Technical Data

Surface finish:	Product contact surfaces: Ra=0.8 μm
Weight:	See reverse page
Lubricant:	Self-lubricating with the cleaning media
Working pressure:	2 - 5 bar (29 - 73 psi)
Recommended pressure:	2 - 4 bar (29 - 58 psi)
Air supply pressure:	2 - 5 bar (29 - 73 psi)
Air quality:	Clean, filtered max. 40 μm. Dry, dew point max. 10°
Max. working temperature:	95 °C (203 °F)
Max. ambient temperature:	150 °C (304 °F)
Wetting radius:	Max. 3.5 m (11 ft)
Impact cleaning radius:	Max. effective 1.7 m (5 ft)
Installation:	Please contact Alfa Laval for installation of the tank cleaning machine

Flow Rate

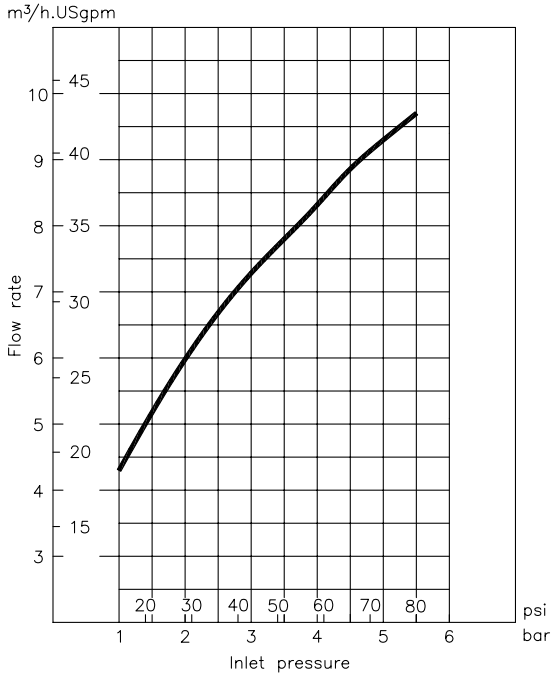

Cleaning Radius

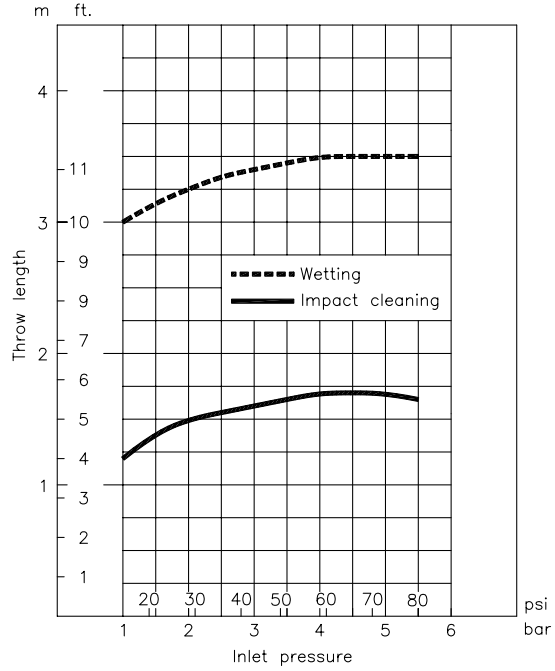

Dimensions (mm)

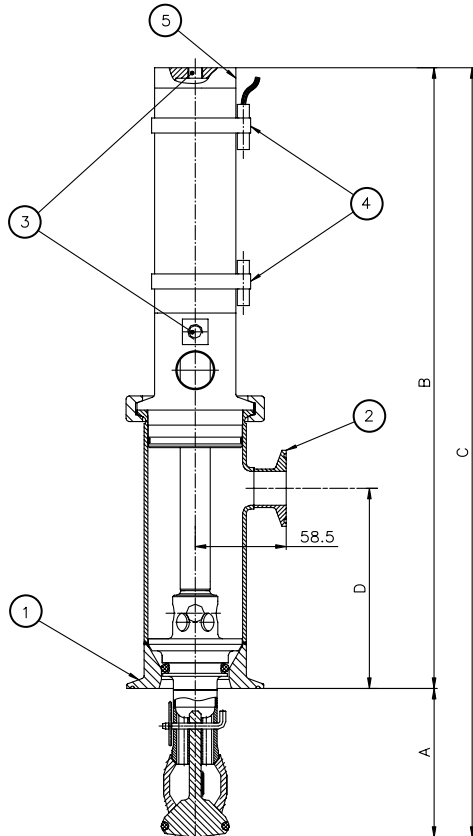

Connections

① Tank connections

TANK CONNECTION		
Clamp	Welded	Welded
3" Clamp ISO 2852	3" ISO 2037/US ø76.1	DN80 DIN 11.850 ø85

② Cleaning media

1" Clamp ISO 2852

③ Air supply - pneumatic driven only

ISO 228-G 1/8

④ Option

Magnetic sensor

⑤ Adjustable valve - media driven only

Pneumatic version

Dimensions (mm)

Stroke	A	B	C	D	Weight
100	100	410	510	133	5.0 kg (11.0 lbs)
150	150	510	660	183	5.5 kg (12.1 lbs)
250	250	710	960	283	6.4 kg (14.1 lbs)

Media driven

Dimensions (mm)

Stroke	A	B	C	D	Weight
100	100	491	591	133	5.6 kg (12.4 lbs)
150	150	621	771	183	6.3 kg (13.9 lbs)
250	250	869	1,119	283	7.4 kg (16.3 lbs)

Ordering

Please specify required connections, material selection and type of certification required and confirm the application suitability.

Options

- Hastelloy C22 (parts in product contact only)
- Alternative sealing component material
- Positioning sensors, which generate digital signals at the fully retracted or fully extended positions
- 3.1.B certificate for metallic parts available upon request