

Product Data Sheet

Horizontal A.C. Brakemotors

Totally Enclosed Fan Cooled Type FCR/BRFCR



- Leroy Somer® Brakemotor
- Design for high cycling applications where numerous start and stop are required.
- Totally Enclosed Fan Cooled motor and brake
- 1/3 - 5 HP; 56 - 184T frames; 1800 through 1200 rpm; 208-230/460 volt
- 1.15 Service Factor
- 40° C ambient
- Die cast aluminum alloy frames - Cast Iron Endshields
- Epoxy Varnish on Wound Stator and Rotor Core
- Class F Insulation With Class B Temperature Rise at Full Load.



EMERSON. CONSIDER IT SOLVED.™

©Emerson Motor Company, 2002; All Rights Reserved!

Product Overview

RIGID BASE

HP	RPM	FRAME	VOLTS	CATALOG NUMBER	TYPE	LIST \$	DS SYM	SF(1)	F.L. EFF	F.L. PF	SHIP WGT	BRAKE TORQUE
1/3	1800	56	208-230/460	BF13S2A3	BRFCR	\$417	DS-3LS	1.15	67.5	74.0	20	4.4
1/2	1800	56	208-230/460	BR12S2A3	BRFCR	\$437	DS-3LS	1.15	66.9	68.0	22	4.4
	1200	56	208-230/460	BR12S3A3	BRFCR	\$483	DS-3LS	1.15	66.9	68.0	38	7.4
3/4	1800	56	208-230/460	BR34S2A3	BRFCR	\$448	DS-3LS	1.15	74.7	74.0	34	4.4
	1200	56	208-230/460	BR34S3A3	BRFCR	\$539	DS-3LS	1.15	73.9	63.0	40	7.4
1	1800	56	208-230/460	BR1S2AF3	BRFCR	\$493	DS-3LS	1.15	76.6	73.0	37	7.4
	1200	145T	208-230/460	BR1S3A3	BRFCR	\$650	DS-3LS	1.15	71.0	64.0	50	14.8
1-1/2	1800	145T	208-230/460	BR32S2A3	BRFCR	\$621	DS-3LS	1.15	77.0	78.0	45	14.8
	1200	145T	208-230/460	BR32S3A3	BRFCR	\$848	DS-3LS	1.15	74.8	66.0	54	14.8
2	1800	145T	208-230/460	BR2S2A3	BRFCR	\$677	DS-3LS	1.15	80.0	77.0	50	14.8
	1200	182T	208-230/460	BR2S3A3	BRFCR	\$833	DS-3LS	1.15	77.0	60.0	65	18.4
3	1800	182T	208-230/460	BR3S2A3	BRFCR	\$825	DS-3LS	1.15	78.8	77.0	60	18.4
	1200	184T	208-230/460	BR3S3A3	BRFCR	\$1,134	DS-3LS	1.15	80.0	69.0	90	23.6
5	1800	184T	208-230/460	BR5S2A3	BRFCR	\$1,100	DS-3LS	1.15	83.7	89.0	90	23.6

C-FACE FOOTED

HP	RPM	FRAME	VOLTS	CATALOG NUMBER	TYPE	LIST \$	DS SYM	SF(1)	F.L. EFF	F.L. PF	SHIP WGT	BRAKE TORQUE
1/3	1800	56C	208-230/460	BR13S2AC3	BRFCR	\$483	DS-3LS	1.15	67.5	74.0	20	4.4
1/2	1800	56C	208-230/460	BR12S2AC3	BRFCR	\$483	DS-3LS	1.15	66.9	68.0	22	4.4
	1200	56C	208-230/460	BR12S3AC3	BRFCR	\$565	DS-3LS	1.15	66.9	68.0	38	7.4
3/4	1800	56C	208-230/460	BR34S2AC3	BRFCR	\$493	DS-3LS	1.15	74.7	74.0	34	4.4
	1200	56C	208-230/460	BR34S3AC3	BRFCR	\$616	DS-3LS	1.15	73.9	63.0	40	7.4
1	1800	56C	208-230/460	BR1S2AFC3	BRFCR	\$541	DS-3LS	1.15	76.6	73.0	37	7.4
	1800	143TC	208-230/460	BR1S2GAC3	BRFCR	\$541	DS-3LS	1.15	76.6	73.0	37	7.4
	1200	145TC	208-230/460	BR1S3AC3	BRFCR	\$741	DS-3LS	1.15	71.0	64.0	50	14.8
1-1/2	1800	145TC	208-230/460	BR32S2AC3	BRFCR	\$693	DS-3LS	1.15	77.0	78.0	45	14.8
	1200	145TC	208-230/460	BR32S3AC3	BRFCR	\$954	DS-3LS	1.15	74.8	66.0	54	14.8
2	1800	145TC	208-230/460	BR2S2AC3	BRFCR	\$760	DS-3LS	1.15	80.0	77.0	50	14.8
	1200	182TC	208-230/460	BR2S3AC3	BRFCR	\$937	DS-3LS	1.15	77.0	60.0	65	18.4
3	1800	182TC	208-230/460	BR3S2AC3	BRFCR	\$937	DS-3LS	1.15	78.8	77.0	60	18.4
5	1800	184TC	208-230/460	BR5S2AC3	BRFCR	\$1,200	DS-3LS	1.15	83.7	89.0	90	23.6

C-FACE FOOTLESS

HP	RPM	FRAME	VOLTS	CATALOG NUMBER	TYPE	LIST \$	DS SYM	SF(1)	F.L. EFF	F.L. PF	SHIP WGT	BRAKE TORQUE
1/3	1800	56C	208-230/460	BR13S2ACR3	BRFCR	\$441	DS-3LS	1.15	67.5	74.0	20	4.4
1/2	1800	56C	208-230/460	BR12S2ACR3	BRFCR	\$461	DS-3LS	1.15	66.9	68.0	22	4.4
	1200	56C	208-230/460	BR12S3ACR3	BRFCR	\$533	DS-3LS	1.15	66.9	68.0	38	7.4
3/4	1800	56C	208-230/460	BR34S2ACR3	BRFCR	\$472	DS-3LS	1.15	74.7	74.0	34	4.4
	1200	56C	208-230/460	BR34S3ACR3	BRFCR	\$587	DS-3LS	1.15	73.9	63.0	40	7.4
1	1800	56C	208-230/460	BR1S2AFCR3	BRFCR	\$533	DS-3LS	1.15	76.6	73.0	37	7.4
	1200	145TC	208-230/460	BR1S3ACR3	BRFCR	\$693	DS-3LS	1.15	71.0	64.0	50	14.8
1-1/2	1800	145TC	208-230/460	BR32S2ACR3	BRFCR	\$669	DS-3LS	1.15	77.0	78.0	45	14.8
	1200	145TC	208-230/460	BR32S3ACR3	BRFCR	\$901	DS-3LS	1.15	74.8	66.0	54	14.8
2	1800	145TC	208-230/460	BR2S2ACR3	BRFCR	\$714	DS-3LS	1.15	80.0	77.0	50	14.8
	1200	182TC	208-230/460	BR2S3ACR3	BRFCR	\$881	DS-3LS	1.15	77.0	60.0	65	18.4
3	1800	182TC	208-230/460	BR3S2ACR3	BRFCR	\$881	DS-3LS	1.15	78.8	77.0	60	18.4
	1200	184TC	208-230/460	BR3S3ACR3	BRFCR	\$1,195	DS-3LS	1.15	80.0	69.0	90	23.6
5	1800	184TC	208-230/460	BR5S2ACR3	BRFCR	\$1,150	DS-3LS	1.15	83.7	89.0	90	23.6



Product Features

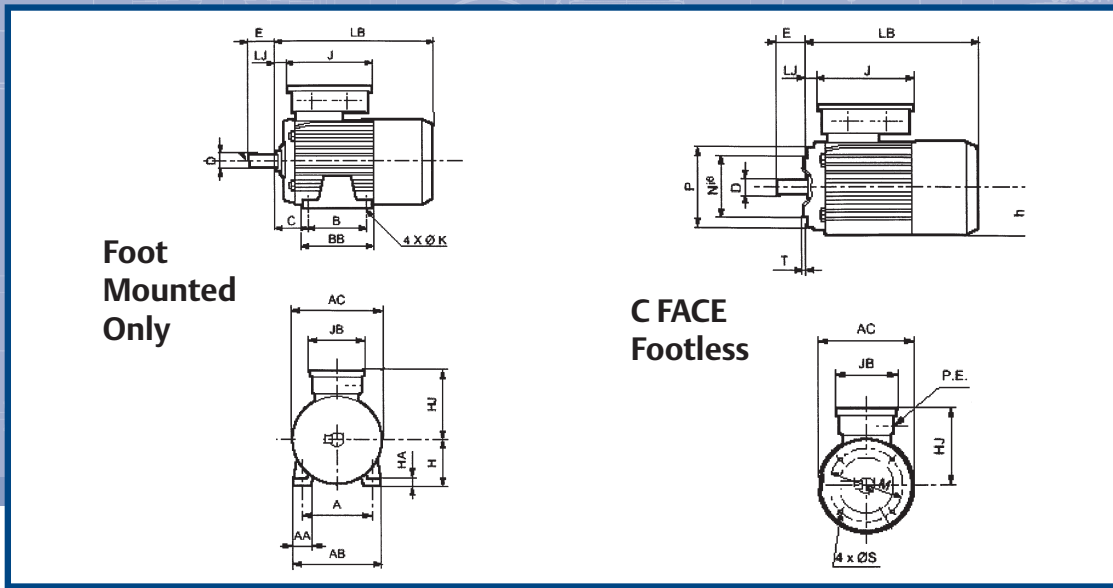

Foot Mounted Only

Frame	A	AA	AB	AC	B	BB	C	Shaft		H	HA	HJ	J	JB	K	LB	LJ
								D	E								
56	4.88	n/a	6.50	6.20	3.00	6.50	2.75	0.625	1.875	3.50	0.12	5.70	6.29	4.33	0.34	10.80	0.94
143	5.50	1.50	6.50	7.00	4.00	6.30	2.25	0.875	2.250	3.50	0.39	6.10	6.29	4.33	0.34	12.04	0.60
145	5.50	1.50	6.50	7.00	5.00	6.30	2.25	0.875	2.250	3.50	0.39	6.10	6.29	4.33	0.34	12.04	0.60
182	7.50	1.65	9.05	7.00	4.50	7.50	2.75	1.125	2.750	4.50	0.63	6.29	6.29	4.33	0.41	13.85	0.57
184	7.50	2.06	8.69	8.66	5.50	6.50	2.75	1.125	2.750	4.50	0.64	6.65	6.29	4.33	0.41	15.60	0.92

All dimensions are in Inches

C FACE Footless

Frame	P	N	D	AC	T	Shaft		HJ	J	JB	S	LB	LJ
						D	E						
56	6.50	4.50	5.875	6.20	0.16	0.625	1.875	5.70	6.29	4.33	0.38	10.80	0.76
143 / 145	6.50	4.50	5.875	7.00	0.12	0.875	2.250	6.10	6.29	4.33	0.38	12.04	0.61
182	9.00	8.50	7.250	7.00	0.25	1.125	2.750	6.29	6.29	4.33	0.50	13.85	0.69
184	9.00	8.50	7.250	8.66	0.25	1.125	2.750	6.65	6.29	4.33	0.50	15.60	1.04

All dimensions are in Inches



Summary

Proven Performance - High cycling capability

The FCR brake motor is the ideal motor for applications with a lot of stops and starts and a quick response time. It can stand more than 1300 starts per hour with a very short response time. This is one of the most reliable substantiate electric motors on the market today for the most demanding of applications. The brake motor combines a motor and a brake in one electromechanical unit. The brake enables the motor and driven machine to be stopped and hold a load.

Areas of Application

A brake motor is used for rhythmic movements: a precise, reduced stopping time is possible when the brake motor is used. It allows emergency stops: it enables virtually instantaneous immobilization and helps ensure the safety of the operator on all "dangerous" machines (saws, presses). The brake enables the motor to remain stopped in position, even if a moment of force remains applied. In lifting applications, the brake stops then maintains the load.

Typical applications are: conveyors, palletizers, baggage handling equipment and general material handling systems.

The motor is available with rigid base, C face footed or C face footless configuration. Options include several choices of braking torque as well as a hand release lever. Air gap is adjusted through a nut at the back of the motor, by simply removing the fan cover. Motor Inertia can be easily modified, by changing the fan disc, to allow the motor to meet high inertia application requirements.

The construction of the motor includes die cast aluminum alloy housings for maximum heat dissipation and higher cycling rates. The stators are varnished using vacuum pressure impregnation process for optimum resistance to moisture and humidity.

The brake coil is contained within the non-drive endshield making the motor extremely compact. The oversized, non regreasable bearings allows longer life to the motor.

F0 terminal box is standard.

Operating Principle

The FCR brakemotor utilizes a fail safe braking principle : when the motor is ON the brake is released.

The brake is released using 180Vdc coil supplied through a rectifier, provided inside the terminal box. The motor/brake connection is suitable for 208/230 or 460Volts without any modification of the brake coil.

When the power is applied the coil is magnetized and compresses the springs through the armature to release the brake.

When the power is switched off, the brake is actuated, springs compress the armature against the brake disc to stop the rotation and apply the braking torque.

Emerson Motor Technologies, a global leader in the design and manufacture of electrical motors, provides a complete line of general and special purpose electric motors from 1/200 through 4,000 horsepower. Brands such as Emerson, Doerr, U.S. Electrical Motors, Hurst, and Switch Reluctance Drives, allow Emerson Motor Technologies to support a wide variety of applications including commercial and industrial, appliance, hermetic, automotive, and HVAC. For more information about Emerson Motor Technologies visit www.emersonmotors.com. St. Louis-based Emerson (www.gotoemerson.com) is a global leader in bringing technology and engineering together to provide innovative solutions to customers in industrial automation; process control; heating, ventilating and air conditioning; electronics and telecommunications; and appliance and tools. Sales in fiscal 2001 were \$15.5 billion.

Emerson Motor Co.
8100 West Florissant Ave.
St. Louis, MO 63136
Phone: 888 637 7333
Fax: 314 553 2087
www.usmotors.com
www.emersonmotors.com

