

HUBBELL ALTERNATOR RELAYS

FORMERLY MANUFACTURED BY FURNAS



**Contact Shown With
Plastic Cover Removed**

Features:

The Class 47 Alternator Is Of Industrial Design Specifically For Use In Pump and Compressor Applications. It Is Easily Field Installed and Wired In Control Panels, Pump Panels Or As A Separately Enclosed Unit For Surface Mounting.

The Alternator Has Single Pole Double Throw Heavy Duty 10 Ampere Silver Cadmium Oxide Contacts Enclosed In A Transparent Dust Cover. The Snap Action Contacts Transfer When The Unit Is De-Energized. The Circuit Is Never Closed Or Opened While Current Is Being Conducted. This Provides Increased Control Life. The Alternator Is Wired To Operate The Second Motor Starter The Next Time A Pump Operation Is Required.

Coil Data:

Watts	Volts 60 Hz	Inrush Open Magnet		Normal Sealed Magnet	
		Amps	VA	Amps	VA
	24	4.0		0.629	
	120	0.8		0.126	
4	240	0.4	96	0.063	15.1
	480	0.2		0.031	

- No Load Transfer
- Industrial Design
- Front Wired
- NEMA Rating A600
- SPDT 10 Amp Contacts
- UL Listed File # E22655
- CSA Certified File # LR6535

Application:

The Alternator Relay Provides A Means Of Automatically Alternating The Operation Of Two Separately Mounted Motor Driven Pumps Or Compressors. This Alternating Action Assures Even Readiness and Wear On Both Pumps.

Electrical Ratings:

NEMA AC Ratings 50/60 Hz
NEMA A600 10 Continuous Amps

Volts	Make	Break
120	60	6
240	30	3
480	15	1.5

Wiring Diagrams (Typical):

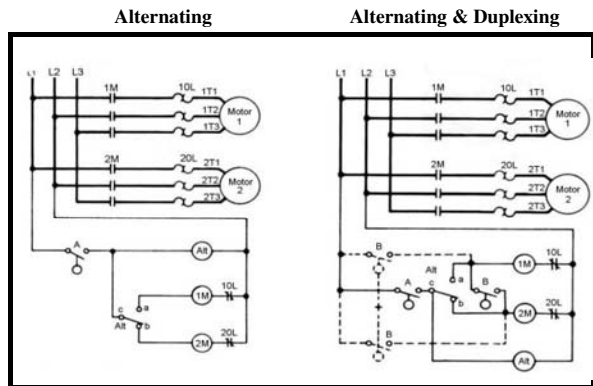

For Added Safety, Replace The Single Pole Float Switch (B) With A 2 Pole Auxiliary (B1) Float Switch (See Dotted Wiring). Switch (A) Is Set To Close Before Switch (B).

Volts 60 Hz	Open Type		NEMA 1 General Purpose	
	Model Number	List Price	Model Number	List Price
24	47AB10AJ	\$312.11	47AB10BJ	\$378.64
120	47AB10AF	\$312.11	47AB10BF	\$378.64
200	47AB10AD	\$312.11	47AB10BD	\$378.64
240	47AB10AG	\$312.11	47AB10BG	\$378.64
480	47AB10AH	\$312.11	47AB10BH	\$378.64