



Product Data Sheet

Horizontal A.C. Motors

Open Dripproof

Energy & Premium Efficient

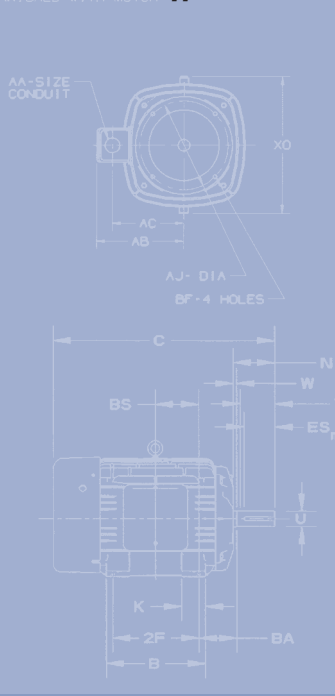
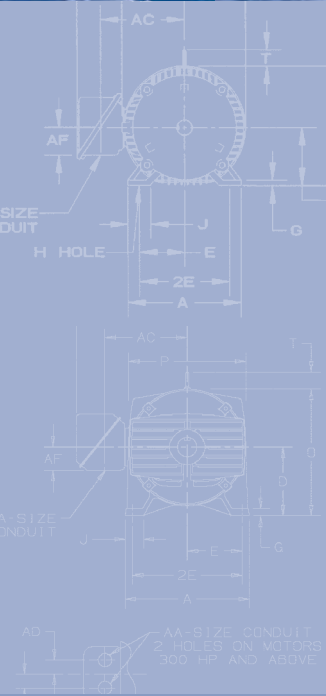

- Open Dripproof
- Energy Efficient
- Premium Efficient **NEMA Premium**
- Steel frame types FD & DE
Cast iron frame types FR & RE
- 1.15 Service Factor
- 1/4 through 400 horsepower
3600, 1800, 1200 rpm
200, 208-230/460 & 575 volt
- ALLGUARD® Motor Quality System



EMERSON. CONSIDER IT SOLVED.™

©Emerson Motor Company, 2003; All Rights Reserved

Product Overview

U.S. Motors' Open Dripproof motor offering consists of two types of products: the steel frame, types FD and DE, which are available from 1/3 through 60 horsepower, and the cast iron frame types FR and RE, available from 60 through 400 horsepower. The FD and FR products meet the federally mandated energy efficiency levels of EPCACT'92, and the DE and RE products are NEMA™ premium efficient products.

Open motors are designed in accordance with NEMA to have a free exchange of air with the ambient. Drops of liquid or solid particles do not interfere with operating at any angle from 0 to 15 degrees downward from the vertical. The open dripproof motor can be used indoors in a relatively clean environment and is commonly used on normal duty industrial equipment such as pumps, fans, blowers, compressors and conveyors.

The steel frame types FD and DE are available with aluminum brackets with steel bearing inserts for improved reliability in severe load applications. The base is steel welded and the 180 frame and larger has a diagonally split conduit box for ease in wiring. Double-shielded bearings with regreasing provisions are

standard for the 250 frame and larger, and lifting lugs are available on the 210 frame and larger. A newly designed steel frame extends the frame of the motor, utilizing a more pancake style end shield, resulting in a better airflow with greater cooling capacity. This motor is also dual voltage (230/460) with 12 leads and is suitable for wye delta start on either voltage.

The cast iron types FR and RE are available from 60 through 400 horsepower, in speeds of 3600, 1800, 1200, 900 and 720 RPM. The motor has both cast iron frame brackets and a diagonally split conduit box. All bearings are double shielded (open bearings on the 440 frame) with regreasing provisions.

In addition to the stock product offerings, custom motors are available, extending the product range for additional ratings and requirements. For a more comprehensive description of our open dripproof motor offering, please consult the U.S. Motors' Catalog. The catalog also includes a complete listing and description of possible modifications and accessories to the open dripproof line, such as space heaters, thermostats, screens and ambients above 40°C.



Product Features



ALLGUARD® Motor Quality System

- New pulse resistant and abrasion resistant wire
- Polyrex EM™ Grease (Exxon-Mobil)
- 100% solids polyester varnish on all windings

U.S. Electrical Motors now offers our new ALLGUARD Motor Quality System on all low voltage NEMA frame motors. This system combines the industry's best motor winding protection with the latest advancements in motor bearing lubrication.

The winding on each low voltage U.S. Motor includes the next generation in pulse endurance wire for improved life. Plus, the wire now features a "Tough Coat" exterior that resists abrasions.

Each winding is also treated with 100% solids insulation material - on all frame sizes - for greater bond strength and moisture resistance.

In addition, U.S. Motors has now standardized on Exxon Mobil Polyrex EM™ grease for grease lubricated bearings. The new and improved lubricant is specifically designed for the conditions associated with electric motor bearings. It provides for increased bearing life at higher loads and temperatures, has low noise properties and has good low temperature starting capabilities.

ALLGUARD® Wire Developments in all U.S. Electrical Motors

- Added to all products in June 2000
- Process and product improvement to standard pulse resistant wire
- Higher Temperature Pulse Endurance Performance
- Incorporation of "Tough Wire" Concepts

ALLGUARD® Polyrex EM™ Grease

offers the following features and benefits...

- Outstanding long-life, high temperature lubrication of ball and roller bearings
- Specially formulated for electric motor bearing lubrication
- Excellent mechanical shear stability
- Excellent corrosion resistance, even in the presence of salt water

100% Solids Polyester Varnish on all windings

with features including...

- 700 times NEMA required humidity resistance
- Approximately 5000 volt dielectric strength at 25°C
- 2 times the film build of water borne varnishes
- 2 times the hot bond strength of epoxy varnish



Stock Product Offering

General Purpose

1-400 HP
56 to 449 Frame
3600-900 rpm
200, 208 & 230/460, 190/380, 575 Volt
Energy Efficient
50/60hz

Fire Pump Motors

5-250 HP
180-445 Frame
3600-1800 rpm
230/460, 575 & 200/400 Volt
50/60 hz ratings
UL & CSA approved
Energy Efficient

Inverter Duty

1-250 HP
140-445 Frame
3600-1800 & 1200 rpm
230/460 Volt
60 hz ratings
Premium Efficient
Exceeds NEMA MG-1 Part 31

Close Coupled Pump

1-60 HP
140-326 Frame
JM, JP & Westcoast Shaft
3600-1800 rpm
Standard & Energy Efficient
50/60 hz available

NEMA™ Premium Efficiency

1-250 HP
140-445 Frame
3600-1800 rpm
230/460, 575 Volt
F2 Available 1-1/2 to 2 HP, 4 pole

C-Face

1-60 HP
140-326 Frame
3600-1800 rpm
208-230/460 Volt
Energy Efficient
50/60 hz

Emerson Motor Technologies, a global leader in the design and manufacture of electrical motors, provides a complete line of general and special purpose electric motors from 1/200 through 4,000 horsepower. Brands such as Emerson, Doerr, U.S. Electrical Motors, Hurst, and Switch Reluctance Drives, allow Emerson Motor Technologies to support a wide variety of applications including commercial and industrial, appliance, hermetic, automotive, and HVAC. For more information about Emerson Motor Technologies visit www.emersonmotors.com.

St. Louis-based Emerson (www.gotoemerson.com) is a global leader in bringing technology and engineering together to provide innovative solutions to customers in industrial automation; process control; heating, ventilating and air conditioning; electronics and telecommunications; and appliance and tools. Sales in fiscal 2002 were \$13.8 billion.

Emerson Motor Co.
8100 West Florissant Ave.
St. Louis, MO 63136
Phone: 888 637 7333
Fax: 314 553 2087
www.usmotors.com
www.emersonmotors.com

