

Models: 165-B, 166-B

Bronze Flanged End Basket Strainers Sizes: 2" - 12" (50 - 300mm)

Pressure/Temperature - Non-Shock		
Model	Material	Rating
165B	Bronze	225psi @ -20 to 150°F
		15.51 bar @ 65.56°C
		150psi @ 406°F
		10.34 bar @ 207.78
166B	Bronze	500psi @ -20 to 150°F
		34.47 bar @ 65.56°C
		350psi @ 350°F
		224.13 bar @ 176.67°C

Max. temp. can be limited by gasket material. Consult factory.

165-B Bronze Class 150
166-B Bronze Class 300



Models 165-B, 166-B

Strainers provide economical protection for costly pumps, meters, valves, and other similar mechanical equipment by straining foreign matter from the connected piping system. Installation of a strainer before mechanical equipment can ensure trouble free service and avoid costly shutdowns for repair or replacement of equipment damaged by foreign matter. The size of the perforation or mesh in the basket screen will determine the smallest particles captured. See Strainer Information section in the Mueller Steam Specialty Engineering binder for detailed information including sizes and materials available.

Service Recommendations

- These strainers can be specified for cooling water, seawater, hot water systems and more.
- They are especially suited for medium or coarse straining. For finer straining, see Model 125.

Features

- The angular cutaway design of the baskets allows a straight through flow, resulting in extremely low pressure drop.
- Tapped and plugged NPT drain on the strainer bottom enables easy self-cleaning on open bottom baskets. Simply open the valve or plug on the outlet to flush accumulated particles.
- Bodies can be tapped for pressure gauges, or per customer requirement. Consult factory.

Construction

- Cover is a flanged bolted design for easy basket removal.

Capacity

Minimum 6 to 1 ratio.

Baskets

MODEL	SIZES	STANDARD (WATER)		STEAM RECOMMENDATION	
		MATERIAL	OPENING	MATERIAL	OPENING
165-B, 166-B	2" - 4"	304SS	.062 perf	304SS	.045 perf
165-B, 166-B	5" and Up	304SS	.125 perf	Consult Factory	

Material

	165-B	166-B
Body	Bronze ASTM B62 (85-5-5-5)	Bronze ASTM B62 (85-5-5-5)
Cover	Bronze ASTM B62 (85-5-5-5)	Bronze ASTM B62 (85-5-5-5)
Gasket	Compressed Fiber	Compressed Fiber

Pressure Drop

See Pressure Drop Charts in Technical Data section of Mueller Steam Specialty Engineering binder.

Dimensions and Weights

SIZE		DIMENSIONS										WEIGHT			
		A				B		C		D (NPT)		165-B		166-B	
in.	mm	in.	mm	in.	mm	in.	mm	in.	mm	in.	mm	lbs.	kgs.	lbs.	kgs.
2	50	8 ⁵ / ₈	219	8 ⁵ / ₈	219	5 ⁷ / ₈	149	4 ³ / ₈	111	1/2	15	37	16	47	21
2 1/2	65	7 ⁹ / ₁₆	189	8 ³ / ₈	213	5 ⁷ / ₁₆	135	3 ³ / ₄	95	3/4	20	37	16	34	15.4
3	80	8 ³ / ₄	222	9 ⁹ / ₁₆	243	5 ¹ / ₄	133	5 ¹ / ₈	130	3/4	20	42	19	63	28
3 1/2	90	10 ³ / ₁₆	259	10 ⁵ / ₈	270	6 ⁷ / ₈	175	5 ¹ / ₄	133	1	25	61	27	82	37
4	100	11 ¹ / ₂	292	11 ¹ / ₂	292	7 ⁷ / ₈	200	5 ³ / ₈	143	1	25	73	33	115	52
5	125	12 ³ / ₈	314	13 ¹ / ₄	337	10 ¹ / ₄	260	5	127	1	25	115	52	149	67
6	150	14	356	15 ¹ / ₂	394	10 ³ / ₈	270	5 ¹³ / ₁₆	148	1 ¹ / ₄	32	141	64	204	92
8	200	17 ¹ / ₈	435	18 ¹ / ₈	460	15 ¹ / ₂	394	7	178	1 ¹ / ₂	40	236	107	310	140
10	250	22	559	23 ¹ / ₄	591	16	406	9 ¹ / ₄	235	1 ¹ / ₂	40	422	191	520	236
12	300	25 ¹ / ₄	645	26 ¹ / ₂	673	23 ³ / ₄	603	11 ⁵ / ₈	295	2	50	855	388	966	439

Apply For Certified Drawings.

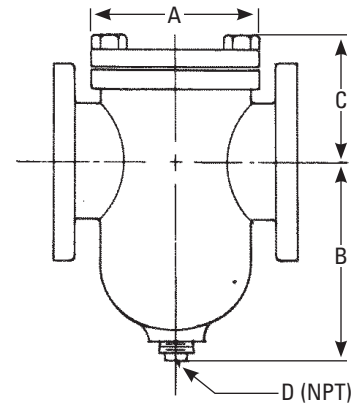

Models 165-B, 166-B

Mueller Steam Specialty product specifications in U.S. customary units and metric are approximate and are provided for reference only. For precise measurements, please contact Mueller Steam Specialty Technical Service. Mueller Steam Specialty reserves the right to change or modify product design, construction, specifications, or materials without prior notice and without incurring any obligation to make such changes and modifications on Mueller Steam Specialty products previously or subsequently sold.



A Division of Watts Water Technologies, Inc.

USA: 1491 NC Hwy 20 West St. Pauls, NC 28384; www.muellersteam.com

Tel: 910-865-8241 Fax: 910-865-6220

Toll Free Phone 1-800-334-6259 Toll Free Fax: 1-800-421-6772