

Installation, Operation and Maintenance

Simplex Basket Strainers

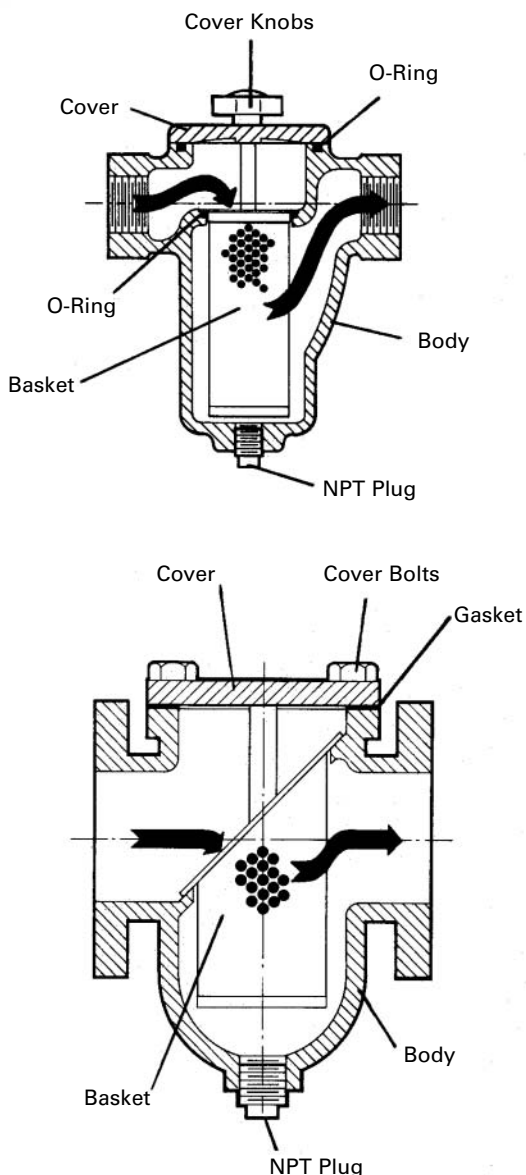

SIMPLEX BASKET STRAINERS SHOULD BE INSTALLED IN THE POSITION SHOWN IN THE ILLUSTRATIONS ABOVE

Warning

Individuals performing removal and disassembly should be provided with suitable protection from possibly hazardous liquids.

Knob and clamp type quick opening covers should not be used for high temperature service. Consult factory for recommendations.

Installation

Before installing the simplex basket strainer, be sure its pressure rating is correct for the system. If the end connections are threaded, be sure the piping is straight and not at an angle or offset. If the strainer has flanged ends, be sure the flanges of the connecting piping are square with the pipe so that no undue stresses are put on the strainer or piping when tightening flange bolts. Tighten bolts in sequence crossing to opposites.

Maintenance

For maximum efficiency, a differential pressure gauge installed across the inlet and outlet will indicate pressure loss due to clogging and may be used, as a guide to determine when cleaning is required. If the strainer is not set up for backwash cleaning, remove the cover access to the basket. After cleaning, replace the basket in the same position as before and tighten cover. Replace the gasket or O-ring if necessary.

Keeping a spare, clean basket will minimize shut down time.

Spare Parts

To order replacement baskets or gaskets and O-rings, which are the only items normally required, specify the following.

- A. Size and model number of strainer or casting number as it appears on the body of the strainer.
- B. Specify service. For example: water, steam, gas, air, oil. The working pressure and temperature of the system and particle size to be strained out should also be specified.

CALIFORNIA PROPOSITION 65 WARNING

WARNING: This product contains chemicals known to the State of California to cause cancer and birth defects or other reproductive harm. (California law requires this warning to be given to customers in the State of California.)

For more information: www.watts.com/prop65

Limited Warranty: Mueller Steam Specialty warrants each product to be free from defects in material and workmanship under normal usage for a period of one year from the date of original shipment. In the event of such defects within the warranty period, the Company will, at its option, replace or recondition the product without charge. This shall constitute the sole and exclusive remedy for breach of warranty, and the Company shall not be responsible for any incidental, special or consequential damages, including without limitation, lost profits or the cost of repairing or replacing other property which is damaged if this product does not work properly, other costs resulting from labor charges, delays, vandalism, negligence, fouling caused by foreign material, damage from adverse water conditions, chemical, or any other circumstances over which the Company has no control. This warranty shall be invalidated by any abuse, misuse, misapplication or improper installation of the product. **THIS WARRANTY IS IN LIEU OF ALL OTHER WARRANTIES, EXPRESS OR IMPLIED, INCLUDING ANY IMPLIED WARRANTIES OF MERCHANTABILITY OR FITNESS FOR A PARTICULAR PURPOSE.** Any implied warranties that are imposed by law are limited in duration to one year.

Some States do not allow limitations on how long an implied warranty lasts, and some States do not allow the exclusion or limitation of incidental or consequential damages. Therefore the above limitations may not apply to you. This Limited Warranty gives you specific legal rights, and you may have other rights that vary from State to State. You should consult applicable state laws to determine your rights.

Mueller Steam Specialty™

A Division of Watts Water Technologies, Inc.

USA: 1491 NC Hwy 20 West St.; Pauls, NC 28384; www.muellersteam.com
Tel: 910-865-8241 Fax: 910-865-6220
Toll Free Phone 1-800-334-6259 Toll Free Fax: 1-800-421-6772