

Description

The type 672 is a compact valve with many features which make it ideal for pharmaceutical and bio-processing applications.

Sanitary Diaphragm Valve

Manually operated

Standard Features

- Compact design
- Stainless steel bonnet with sanitary internals
- Visual position indicator
- FDA compliant diaphragms
- Triclamp®, O.D. Tubing, ISO, and DIN end connections
- Sizes 1/2" - 4"

Available Options

Special connections

Hose barb, tube extensions, Swagelok®, Cajon VCR®, Ingold®, and others available upon request.

Fabrications

Cluster valve assemblies for both horizontal and vertical orientations, Zero Static T-valves, Duplex, Multiported, Tank Bottom, and custom fabrications upon request.

Materials

AL-6XN®, Hastelloy®, Titanium®, and others available upon request.

Bonnet Options

Sealed bonnet, "V" notch vent plug, extended handwheel, external adjustable travel stop, electrical position indicator, and others available upon request.



Typical Applications

- Pharmaceutical manufacturing
- Bioprocessing
- Cosmetic
- Brewery Service
- Food and Beverage
- Semiconductor
- High Purity Chemicals

Type 672

Type 672 Technical Data

Size (Inches)	Nominal diameter (mm)	Working pressure (psi)	Body configuration (D = straight through)	C _v value (gpm)		Weight (lbs)
				ISO	O.D. Tubing	
1/2	15	0 - 150	D	-	-	3.3
3/4	20	0 - 150	D	5.1	-	3.3
1	25	0 - 150	D	14.6	-	3.3
1 1/4	32	0 - 150	D	-	-	6.1
1 1/2	40	0 - 150	D	34.5	-	6.1
2	50	0 - 150	D	59.2	-	11.1
2 1/2	65	0 - 150	D	80.1	-	30.1
3	80	0 - 150	D	101.8	-	30.1
4	100	0 - 150	D	220	-	59.4

All pressures are gauge pressures when applied upstream. The C_v values vary due to differences in valve construction (i.e., Port size, body material, diaphragm material, etc.)

Working pressure: 0 - 150 psi

Max. perm. Temperature of working medium: 302°F (150°C) (depending on diaphragm material/cycle time)

The valve will seal against flow in either direction up to a working pressure of 150 psi (gauge pressure).

Body Configuration	Ref.no.	Diaphragm material	Ref.no.
Tank bottom valve body	B	2nd generation, modified Teflon® with Ethylene-propylene backing 2-piece molded closed	TFM/EPDM 5E
2-way valve body	D		
2-way angled valve body	E		
Multiported valve body	M	2nd generation, modified Teflon® with Silicone backing 2-piece molded closed	TFM/VMQ 5S
Zero Static T-Valve	T		
U-bend	U	Ethylene-propylene Rubber for saturated steam max 302° F	EPDM 13

Connection	Ref.no.	Diaphragm material	Ref.no.
DIN	0	Ethylene-propylene Rubber for saturated steam max 302° F	EPDM 16
DIN 11850/Series 1	16	2nd generation, modified Teflon® with Ethylene-propylene backing (2-piece)	TFM/EPDM 50
DIN 11850/Series 2	17		
DIN 11850/Series 3	18	2nd generation, modified Teflon® with Ethylene-propylene backing	TFM/EPDM 52
Butt weld OD tubing	59		
Sizes 1/4-3/8" 20 gauge .035" wall			
Sizes 1/2-3" 16 gauge .065" wall			
Sizes 4" 14 gauge .083" wall			
ISO	60	<i>All diaphragms listed conform to the FDA code of Federal Regulations paragraph 177.2600 of section 21.</i>	
Schedule 10 pipe	63		
Tri-clamp®	80		
O.D. Tubing by Triclam®	93		
Extended O.D. Tubing	94		
Extended O.D. Tubing by Triclam®	95		

Control function	Ref.no.
Manually operated	0

Body material	Ref.no.	Surface finish	Ref.no.
Investment cast body			
Stainless steel 316 L Δ 1.4435 (BN2) Fe < 0.5%	32		
Stainless steel 1.4539 (UNS N 08904)	33		
Forged Body			
Stainless steel 316 L Δ 1.4435 (ASTM A 182)	40		
Stainless steel 316 L Δ 1.4435 (BN2) Fe < 0.5%	42		
Machined block			
Stainless steel 316 L Δ 1.4435 (ASTMA 479)	41		
Special versions (Consult factory for special material reference numbers)	91		

μ -in.	BPE Surface Designation	Ra Average [Note (1)]		Ra Max			
		μ -in.	μ m	μ -in.	μ m		
32	Mechanical					3	
25	Mechanical	SFV3	25	0.625	30	0.750	1502
20	E-pol	SFV6	20	0.500	25	0.625	1508
20	Mechanical	SFV2	20	0.500	25	0.625	1507
15	E-pol	SFV5	15	0.375	20	0.500	1537
11	Mechanical	SFV1	15	0.375	20	0.500	1536
10	E-pol	SFV4	10	0.250	15	0.375	1516

GENERAL NOTE: All Ra readings are taken across the grain.
NOTE: (1) The average Ra is derived from two readings taken at different locations.

Special Versions	Ref.no.
Special versions	UXXXX

Order Example	-672	015	U	80	41	13	0		040	94	1537	
Type of valve	-672											
Size DN		015										
Body configuration			U									
Connection (valve body)				80								
Body material					41							
Diaphragm material						13						
Control function							0					
Actuator size												
Locking device												
Pipe main size									040			
Pipe main connection										94		
Surface finish											1537	
Special versions (XXXX)												

Type 672 Dimensional Data

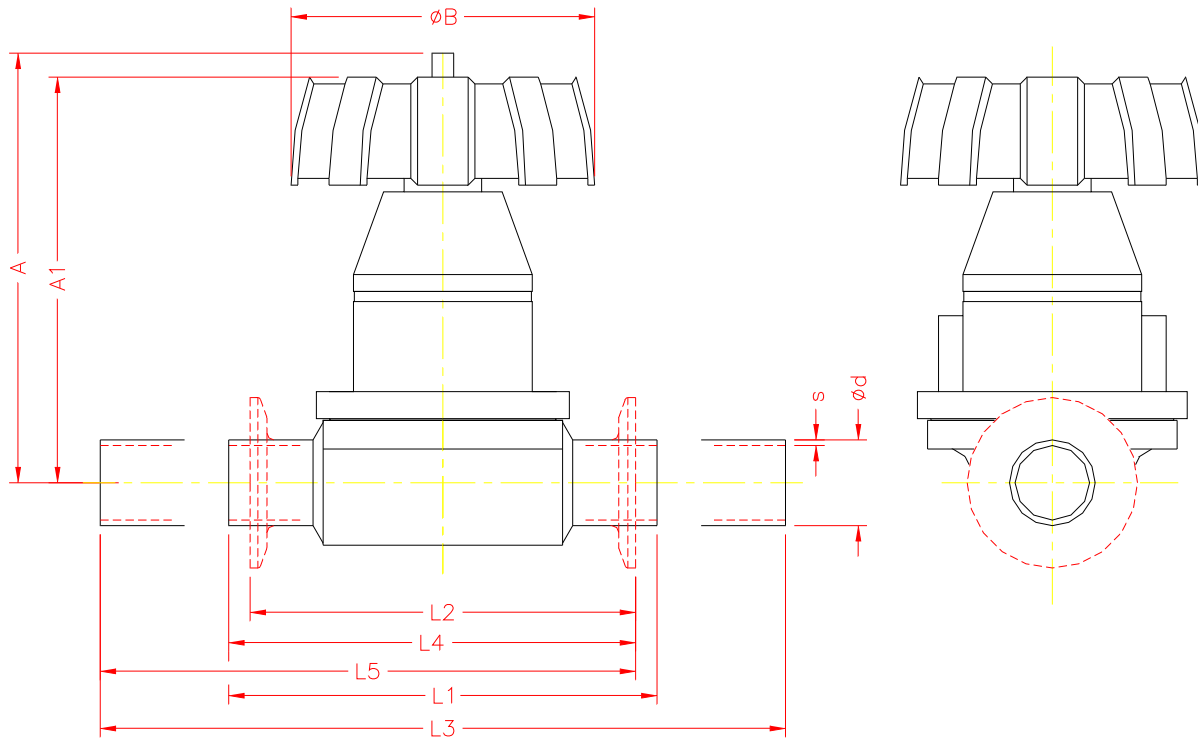

Take Out Dimensions for Standard Connections

Size	DN	Units	Con. Ref. No.	Ød	s	(59) L1	(80) L2	(94) L3	(93) L4	(95) L5
1/2	15	mm	12.70	1.65	120.00	101.60	184.15	110.80	142.88	
		in	0.500	0.065	4.724	4.000	7.250	4.362	5.625	
3/4	20	mm	19.05	1.65	120.00	101.60	190.50	110.80	146.05	
		in	0.750	0.065	4.724	4.000	7.500	4.362	5.750	
1	25	mm	25.40	1.65	120.00	114.30	203.20	117.15	158.75	
		in	1.000	0.065	4.724	4.500	8.000	4.612	6.250	
1 1/2	40	mm	38.10	1.65	153.00	139.70	234.95	146.35	187.33	
		in	1.500	0.065	6.024	5.500	9.250	5.762	7.375	
2	50	mm	50.80	1.65	173.00	158.75	266.70	165.88	212.73	
		in	2.000	0.065	6.811	6.250	10.500	6.531	8.375	
2 1/2	65	mm	63.50	1.65	216.00	193.68	292.10	204.84	242.89	
		in	2.500	0.065	8.504	7.625	11.500	8.065	9.563	
3	80	mm	76.20	1.65	254.00	222.25	333.38	238.13	277.82	
		in	3.000	0.065	10.000	8.750	13.125	9.375	10.938	
4	100	mm	101.60	2.10	305.00	292.10	406.40	298.55	349.25	
		in	4.000	0.083	12.008	11.500	16.000	11.754	13.750	

Drain Angles

Size	DN	Degrees
1/2	15	46°
3/4	20	55°
1	25	60°
1 1/4	32	65°
1 1/2	40	65°
2	50	70°
2 1/2	65	70°
3	80	70°
4	100	70°

Drain angles are for BS O.D. Tubing only.

- L1 = Connection Code 59 = Standard butt-weld
- L2 = Connection Code 80 = Standard clamp
- L3 = Connection Code 94 = Standard butt-weld extension (AWF)
- L4 = Connection Code 93 = Standard clamp X butt-weld
- L5 = Connection Code 95 = Standard clamp X butt-weld extension (AWF)

Optional Spigot Dimensions

Connection Ref. No.	60	0	16	17	18	37							
Size DN	L₁	d	s	d	s	d	s	d	s	d	s	d	s
1/2"	15	120	21,3	1,6	18	1,5	18	1	19	1,5	20	2	-
3/4"	20	120	26,9	1,6	22	1,5	22	1	23	1,5	24	2	-
1"	25	120	33,7	2,0	28	1,5	28	1	29	1,5	30	2	25,0
1 1/4"	32	153	42,4	2,0	34	1,5	34	1	35	1,5	36	2	33,7
1 1/2"	40	153	48,3	2,0	40	1,5	40	1	41	1,5	42	2	38,0
2"	50	173	60,3	2,3	52	1,5	52	1	53	1,5	54	2	51,0
2 1/2"	65	216	76,1	2,6	-	-	70,2	2	-	-	-	-	63,5
3"	80	254	88,9	2,6	-	-	85	2	-	-	-	-	76,1
4"	100	305	114,3	2,6	-	-	104	2	-	-	-	-	101,6

Dimensions

Size	DN	Units	A	A1	ØB
1/2	15	mm	129.0	120.0	90.0
		in	5.08	4.72	3.54
3/4	20	mm	129.0	120.0	90.0
		in	5.08	4.72	3.54
1	25	mm	129.0	120.0	90.0
		in	5.08	4.72	3.54
1 1/4	32	mm	160.0	151.0	114.0
		in	6.30	5.94	4.49
1 1/2	40	mm	160.0	151.0	114.0
		in	6.30	5.94	4.49
2	50	mm	182.0	173.0	140.0
		in	7.17	6.81	5.51
3	80	mm	294.0	285.0	215.0
		in	11.57	11.22	8.46
4	100	mm	339.0	330.0	215.0
		in	13.35	12.99	8.46

Type 672 Dimensional Data

GEMÜ® Zero Static T-Valve

Standard Features

- Sterile design
- Mechanical parts isolated from process
- Zero dead-leg with no bacteria entrapment
- Maximum drainage, leaving virtually no residue
- Body machined from 316L stainless steel solid bar stock or specified material
- Compact design
- Tube length for automatic orbital welding

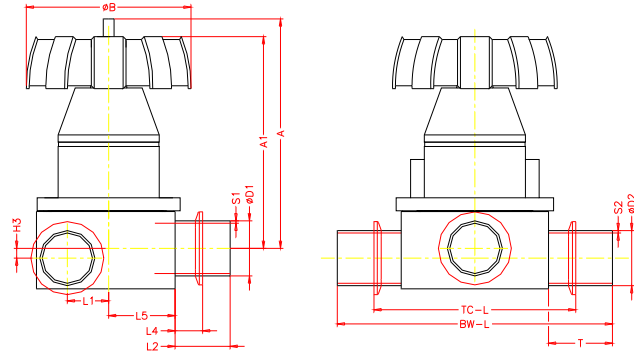

D1 x D2	Units	D1	s1	D2	s2	H3	L1	Code 59			Code 94			Code 80					
								L2	T	BW-L	L2	T	BW-L	L4	L5	TC-L	A	A1	ØB
1/2 x 1	mm	12.7	1.65	25.4	1.65	4.5	17.9	20.0	25.0	124.0	38.1	51.9	177.8	19.7	34.0	113.4	129.0	120.0	90.0
	in	0.500	0.065	1.000	0.065	0.2	0.7	0.8	1.0	4.9	1.5	2.0	7.00	0.8	1.3	4.5	5.1	4.7	3.5

Size DN | 1/8 | 3/8 | 1/2 | 3/4 | 1 | 1 1/2 | 2 | 2 1/2 | 3 | 4
 DN | 8 | 10 | 15 | 20 | 25 | 40 | 50 | 65 | 80 | 100

TOL ±1mm Note: Dimension subject to change

GEMÜ® VALVES, ACTUATORS AND CONTROL SYSTEMS

REVISION 12/06/00

Type 672 Dimensional Data

GEMÜ® Tank Bottom / Side Sampling Diaphragm Valve

Standard Features

- Sterile design
- Mechanical parts isolated from processes
- Designed to minimize fluid flow resistance
- Maximum drainage, leaving virtually no residue
- Pocket-free interior surface with no entrapment areas
- Body machined from 316L stainless steel bar stock ASME SA-479 (UNS S31 603)
- Complies with ASME Boiler & Pressure Vessel code requirements, section VIII Division #1

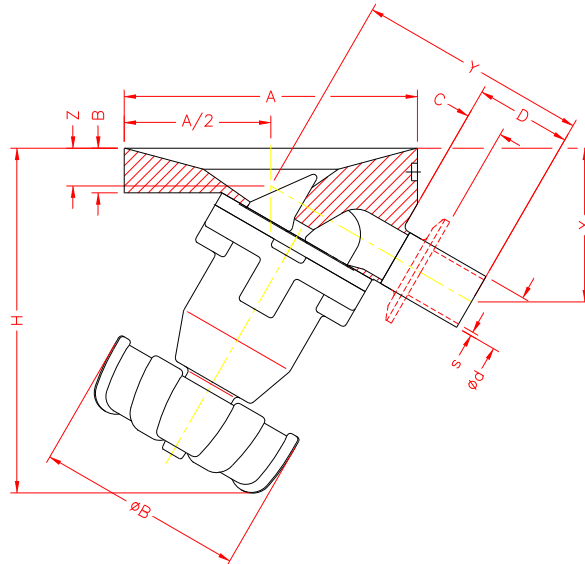

Typical Applications

- Media fill and transfer vessels
- CIP (*clean-in-place*) tanks
- Bioreactor & Fermentation vessels
- Water for Injection storage vessels (WFI)
- Sterile receivers
- Any process vessels used in pharmaceutical / bioprocessing applications

Size	DN	59		A	A/2	B	C	D	X	Y	Z	ØB	H
		Ød	s										
1/2	15	mm 12.70 0.500	1.65 0.065	127.00 5.000	63.50 2.500	19.30 0.760	16.06 0.632	41.46 1.632	72.11 2.839	96.56 3.802	23.83 0.938	90.00 3.543	146.30 5.760
3/4	20	mm 19.05 0.750	1.65 0.065	127.00 5.000	63.50 2.500	19.30 0.760	16.06 0.632	41.46 1.632	69.35 2.730	98.39 3.874	21.08 0.830	90.00 3.543	146.30 5.760
1	25	mm 25.4 1.000	1.65 0.065	127.00 5.000	63.50 2.500	19.30 0.760	16.06 0.632	41.46 1.632	66.50 2.618	100.30 3.949	16.35 0.644	90.00 3.543	146.30 5.760
1 1/2	40	mm 38.1 1.500	1.65 0.065	177.80 7.000	88.90 3.500	22.22 0.875	17.46 0.687	42.86 1.687	77.73 3.060	122.23 4.812	16.62 0.654	114.00 4.488	177.50 6.988
2	50	mm 50.8 2.000	1.65 0.065	203.20 8.000	101.60 4.000	25.40 1.000	17.46 0.687	42.86 1.687	84.41 3.323	133.01 5.237	17.90 0.705	114.00 4.488	208.50 8.209
2 1/2	65	mm 63.5 2.500	1.65 0.065	203.20 8.000	101.60 4.000	25.40 1.000	17.46 0.687	42.86 1.687	79.02 3.111	136.62 5.379	10.72 0.422	140.00 5.512	208.50 8.209
3	80	mm 76.2 3.000	1.65 0.065	266.70 10.500	133.35 5.250	28.57 1.125	16.66 0.656	42.06 1.656	103.95 4.093	169.39 6.669	19.26 0.758	215.00 8.465	321.30 12.650
4	100	mm 101.6 4.000	2.00 0.079	368.30 14.500	184.15 7.250	31.75 1.250	22.23 0.875	44.45 1.750	133.31 5.248	213.88 8.420	26.36 1.038	215.00 8.465	360.20 14.181

TOL ±1mm Note: Dimension subject to change

Size	1/4	3/8	1/2	3/4	1	1 1/2	2	2 1/2	3	4
DN	8	10	15	20	25	40	50	65	80	100

Order Example	-672	025	B	80	41	13	0						1537
Type of valve	-672												
Size DN		025											
Body configuration			B										
Connection (valve body)				80									
Body material					41								
Diaphragm material						13							
Control function							0						
Actuator size													
Locking device													
Pipe main size													
Pipe main connection													
Surface finish													1537
Special version (XXXX)													



Type 672 Spare Parts

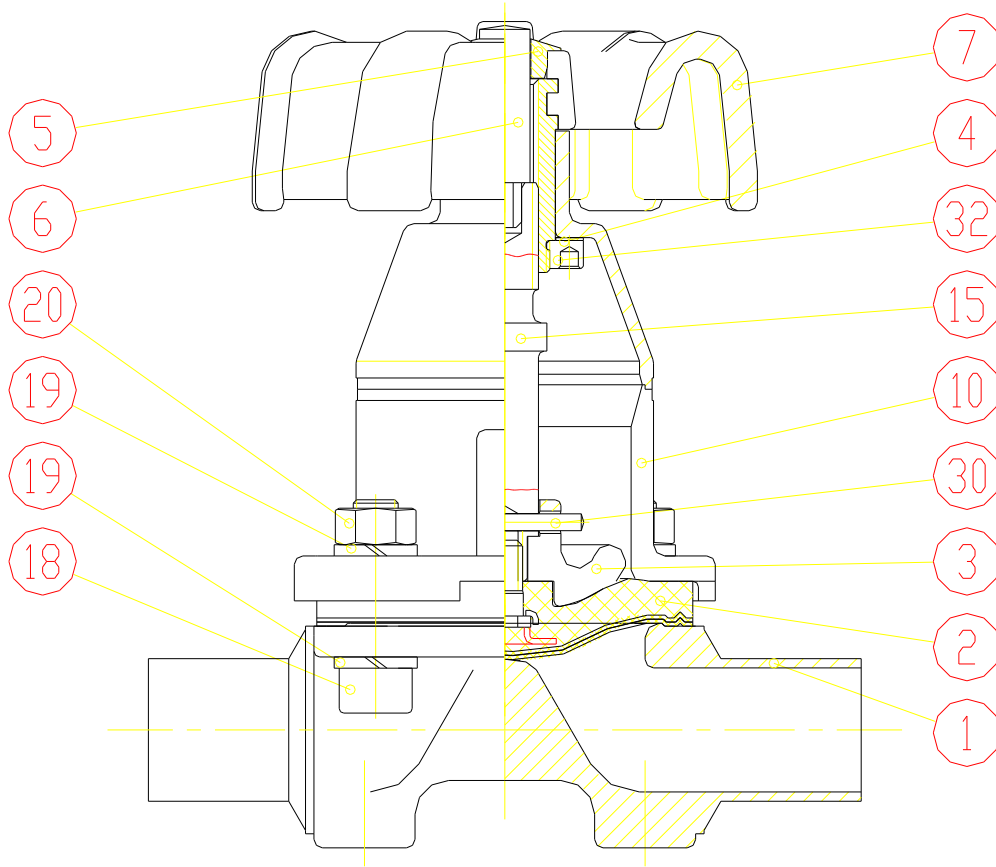

ITEM	PART
1	Valve Body
2	Process Diaphragm
3	Compressor
4	Bearing Plate
5	Bushing
6	Optical Position Indicator
7	Hand Wheel
10	Bonnet
15	Spindle
18	Socket-Head Bolt
19	Spring Washer
20	Hex. nut
30	Pin
32	Retaining Clip