

Maximum Pipe Size:
6" Inside diameter
8.5" Outside diameter

Specification and Data Sheet

MODEL NO. 6-RAH-7 and 6-RAH-12

- Product Name:** PILLOW BLOCK PIPESTAND MODEL 6-RAH-7 AND 6-RAH-12 **NOTE:** Pillowblock pipestand model numbers correspond to usual pipe names. Pipe that is called "six inch" or 6" pipe has a 6" inside diameter and a larger outside diameter. Model 6-RAH-7 and 6-RAH-12 will hold up to all usual and customary 6" and smaller pipe sizes, referring to the inside diameter. The maximum outside dimension of the pipe or conduit the Model 6-RAH-7 and 6-RAH-12 will hold is 8.5" diameter.
- Manufacturer:** MIRO INDUSTRIES, INC., 2700 South 900 West, Salt Lake City, Utah 84119 Phone (800) 768-6978
Fax (800) 440-7958
- Product Description:** A "roller-bearing" pipe support used to support roof mounted gas pipes, electrical conduit, solar piping and other mechanical piping. Unique design absorbs thermal expansion and contraction of pipes thus preventing damage to the roof membrane. Pipes rest on a self-lubricating roller which is a 304 stainless steel rod and a polycarbonate resin roller. The pipe support base is made of sturdy polycarbonate resin, the roller is polycarbonate and all metal parts are made of stainless steel. Pipestand will accommodate up to 6" inside diameter pipe or up to 8.5" outside diameter pipes.
- Product Performance:** The "U" shaped roller serves to keep the pipestand roller system directly beneath the pipe without binding and allows for some lateral expansion of the piping system. The base is gently rounded to prevent gouging.
- Compatibility:** Pillow Block Pipestands are recommended for use on and are compatible with all current types of decking with all commonly used built-up and single-ply roofing membranes where roof-mounted pipes occur.
- Load Weight:** Maximum load weight may not exceed 250 lbs. per pipestand.
- Composition and Materials:** The pipestand consists of two major components: (1) A one-piece polycarbonate resin roof deck base, pipe support, and adjustable roller housing, (2) A roller made of polycarbonate resin and a stainless steel rod which rests in an adjustable height roller housing on the 6-RAH. Carbon black is added to the polycarbonate resin for UV resistance and protection.
- Size:** Pillow Block Pipestand Model 6-RAH-7 and 6-RAH-12 is made in one standard size. The deck is 16" x 18" and has a maximum cradle width of 8.5". The 6-RAH-7 can adjust in height from a low of 4.5" to a high of 7.5" from bottom of pipe support. The 6-RAH-12 can adjust in height from a low of 4.5" to a high of 12".
- Installation:** (1) Center the pipestand beneath the pipe so that the cradle allows the pipe to be squarely over and through the roller of the pipestand. (2) Adjust the pipestand to the desired height and to even load with other pipestands. Make certain the strut or roller is level. (3) Set the pipe in the pipestand without dropping or causing undue impact. If desired, an additional sheet of roofing material, a MIRO Support Pad, or a MIRO Deck Plate can be installed beneath the pipestand. For built-up roofs, all loose aggregate from an area 20" square should be removed from the area directly beneath the pipestand and then follow the installation directions set forth above. Care should be taken to install each pipestand so it supports a proportional and equal amount of weight at each pipestand.
- Spacing:** Manufacturer's recommended spacing is not to exceed 10 foot centers depending upon the load. Do not exceed 250 lbs. load weight and make certain each pipestand is adjusted in height to even load.
- Availability:** Pillow Block pipestands are marketed throughout the United States through representatives and distributors.
- Maintenance:** Normally maintenance is not required. Semi-annual inspection is required to check pipestand position and set pipe alignment, weight distribution and improper installation which may cause pipestand damage or failure.
- Technical Services:** Please call MIRO INDUSTRIES, INC.: (800) 768-6978.
www.miroind.com for technical information and for graphic and for CAD drawing downloads.

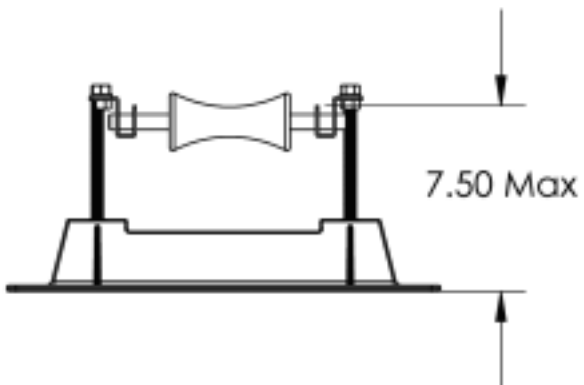
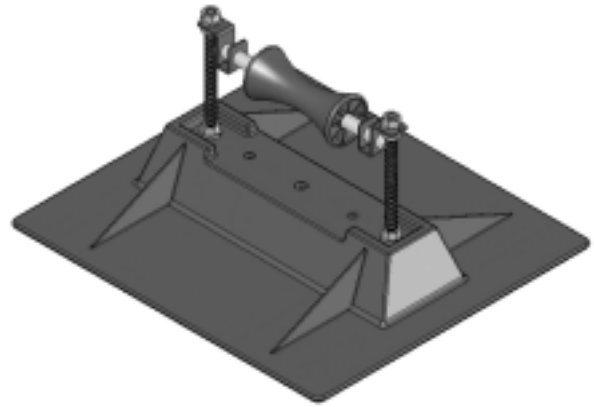
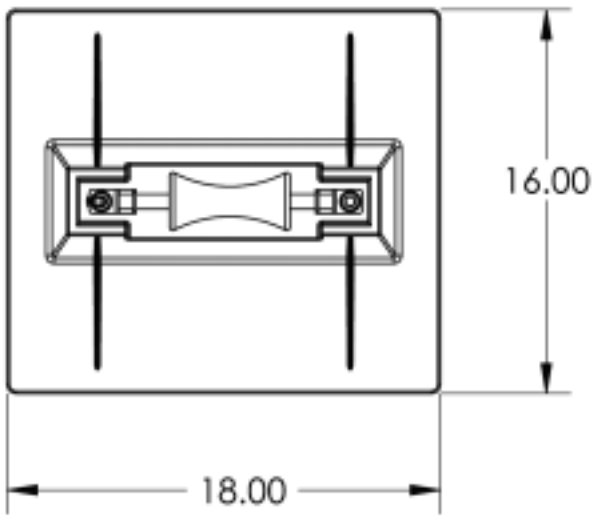

This document, attachments, and all of the information therein are the property of MIRO Industries, Inc. The information contained is loaned, subject to return upon demand, and is not to be used directly or indirectly in any way detrimental to our interest. Further, the information contained therein shall not be used, in whole or in part, except when allowed by written authorization from MIRO Industries, Inc.

Copyright MIRO Industries, Inc. 2003.

6-RAH-7

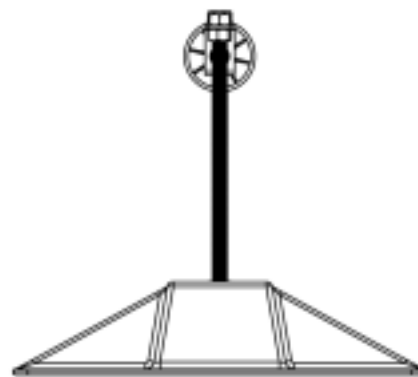
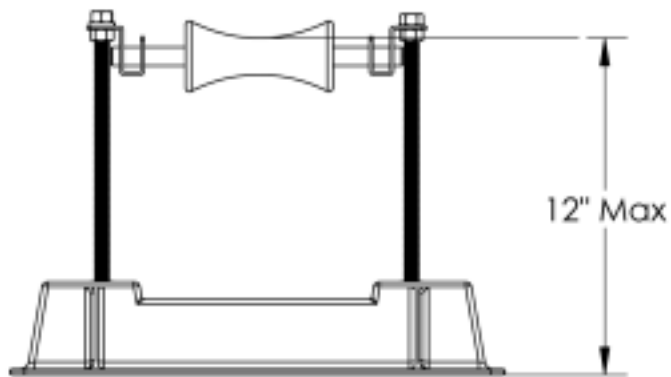
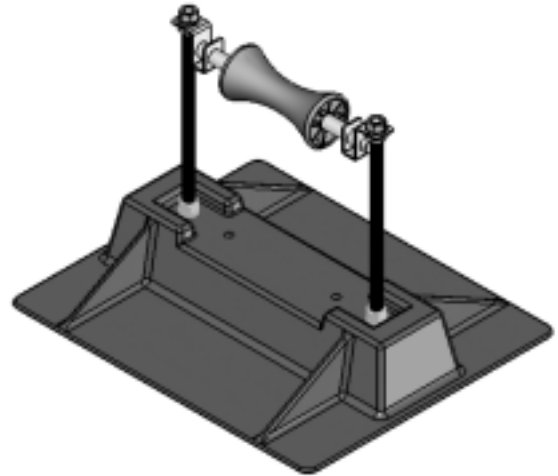
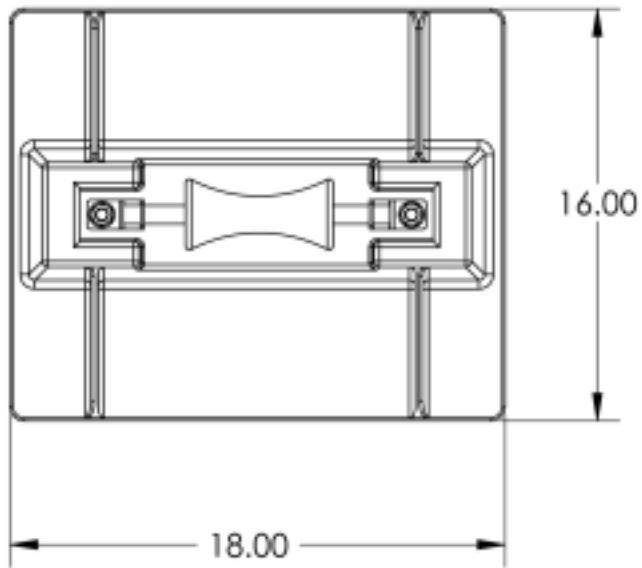

This document, attachments, and all of the information therein are the property of MIRO Industries, Inc. The information contained is loaned, subject to return upon demand, and is not to be used directly or indirectly in any way detrimental to our interest. Further, the information contained therein shall not be used, in whole or in part, except when allowed by written authorization from MIRO Industries, Inc.

Copyright MIRO Industries, Inc. 2003.

6-RAH-12